



©2023 Lennox Industries Inc.
Dallas, Texas, USA



THIS MANUAL MUST BE LEFT WITH THE HOMEOWNER FOR FUTURE REFERENCE

⚠ WARNING

Improper installation, adjustment, alteration, service or maintenance can cause property damage, personal injury or loss of life. Installation and service must be performed by a licensed professional HVAC installer or equivalent, or service agency.

⚠ IMPORTANT

The Clean Air Act of 1990 bans the intentional venting of refrigerant (CFCs, HCFCs and HFCs) as of July 1, 1992. Approved methods of recovery, recycling or reclaiming must be followed. Fines and/or incarceration may be levied for noncompliance.

⚠ CAUTION

As with any mechanical equipment, contact with sharp sheet metal edges can result in personal injury. Take care while handling this equipment and wear gloves and protective clothing.

SETTING THE UNIT – Clearances

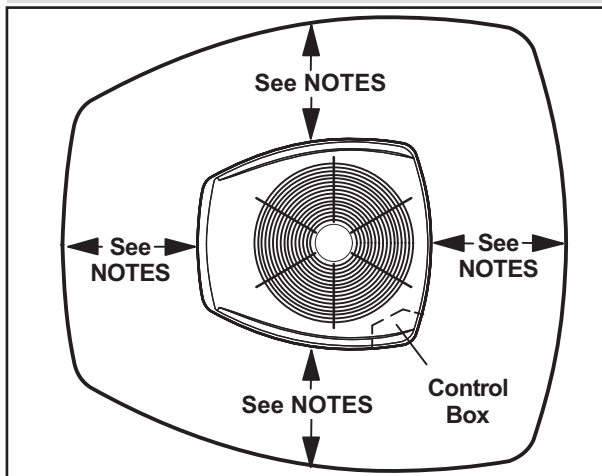

NOTES:

Service clearance of 30 in. (762 mm) must be maintained on one of the sides adjacent to the control box.

Clearance to one of the other three sides must be 36 in (914 mm).

Clearance to one of the remaining two sides may be 12 in. (305mm) and the final side may be 6 in.(152 mm).

A clearance of 24 in. (610 mm) must be maintained between two units.

48 in. (1219 mm) clearance required on top of unit.

INSTALLATION INSTRUCTIONS

Elite® Series EL18XCV Units

AIR CONDITIONER
507955-01
9/2023

PACKING LIST



OUTDOOR UNIT



WARRANTY CERTIFICATE



RAST 6-PIN CONNECTORS (2)

General

This EL18XCV outdoor air conditioner **with all-aluminum coil** is designed for use with HFC-410A refrigerant only. This unit must be installed with an approved indoor air handler or coil. For AHRI Certified system match-ups and expanded ratings, visit www.LennoxPros.com. The EL18XCV variable capacity unit may be installed with an S30 communicating thermostat or a standard 24VAC non-communicating thermostat. See field wiring diagrams for wiring details. These instructions are intended as a general guide and do not supersede local codes in any way. Consult authorities having jurisdiction before installation.

NOTICE!

Charging information is given on the charging procedure sticker on the unit access panel. For more in-depth information, consult the Installation and Service Procedures manual on LennoxPros.com or through the Technical Support department at 800-453-6669.

IMPORTANT: Special procedures are required for cleaning the all-aluminum coil in this unit. See page 20 in this instruction for information.



UNIT DIMENSIONS – INCHES (MM)

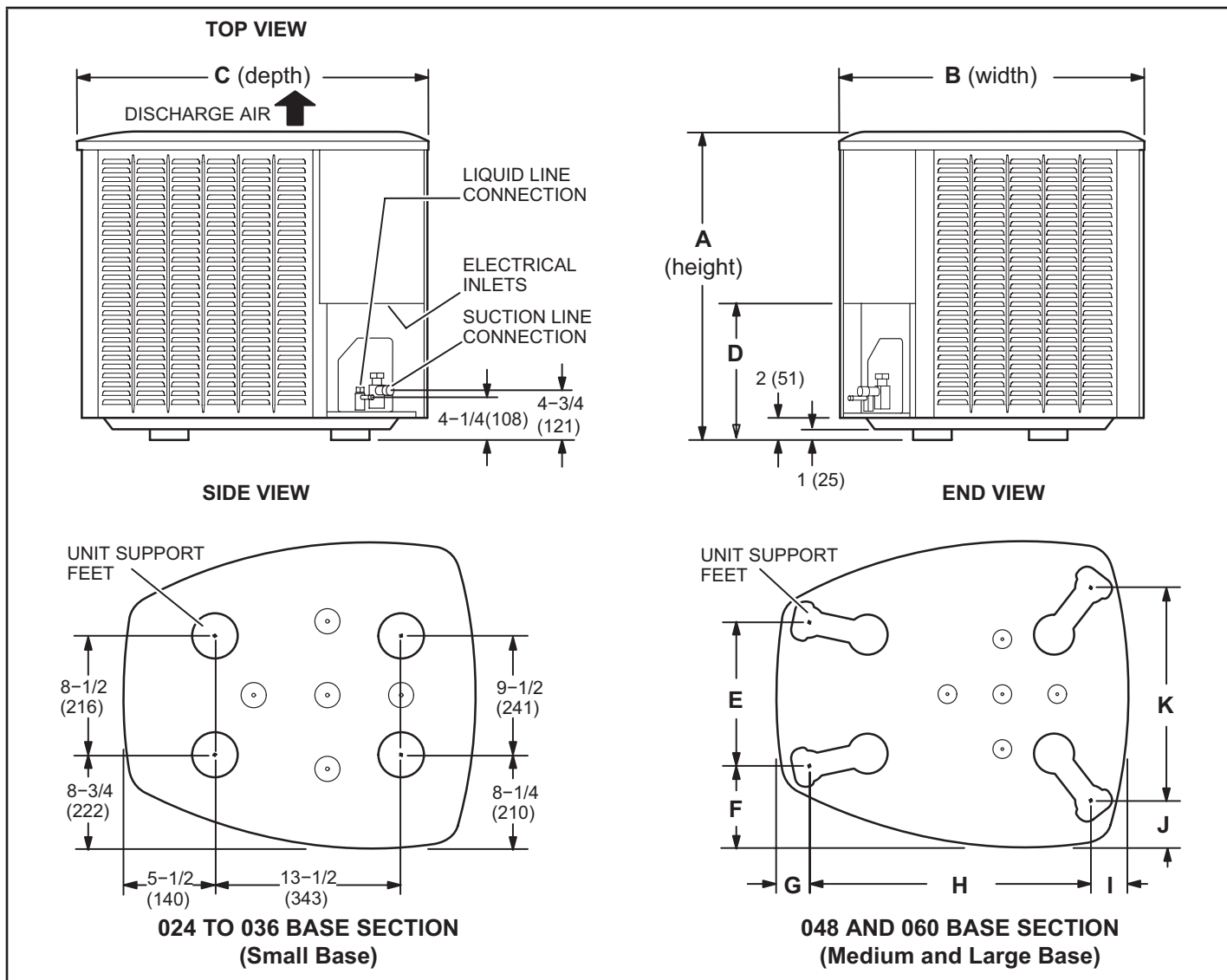

| Model | A (Height) | | B (Width) | | C (Depth) | | D | | E | | F | | G | | H | | I | | J | | K | | |
|------------|------------|------|-----------|-----|-----------|------|--------|-----|--------|-----|-------|-----|-------|-----|--------|-----|-------|-----|-------|-----|--------|-----|-----|
| | in. | mm | in. | mm | in. | mm | in. | mm | in. | mm | in. | mm | in. | mm | in. | mm | in. | mm | in. | mm | in. | mm | |
| -024, S024 | 35 | 889 | 27 | 686 | 28 | 711 | 8 | 203 | --- | --- | --- | --- | --- | --- | --- | --- | --- | --- | --- | --- | --- | --- | --- |
| -036, S036 | 35 | 889 | 27 | 686 | 28 | 711 | 8 | 203 | --- | --- | --- | --- | --- | --- | --- | --- | --- | --- | --- | --- | --- | --- | --- |
| -048, S048 | 45 | 1143 | 30-1/2 | 775 | 35 | 889 | 11-5/8 | 295 | 13-7/8 | 352 | 7-3/4 | 197 | 3-1/4 | 83 | 27-1/8 | 689 | 3-5/8 | 92 | 4-1/2 | 114 | 20-5/8 | 524 | |
| S060 | 45 | 1143 | 30-1/2 | 775 | 35 | 889 | 11-5/8 | 295 | 13-7/8 | 352 | 7-3/4 | 197 | 3-1/4 | 83 | 27-1/8 | 689 | 3-5/8 | 92 | 4-1/2 | 114 | 20-5/8 | 524 | |
| -060 | 45 | 1143 | 35-1/2 | 902 | 39-1/2 | 1003 | 11-5/8 | 295 | 16-7/8 | 429 | 8-3/4 | 222 | 3-1/8 | 79 | 30-3/4 | 781 | 4-5/8 | 117 | 3-3/4 | 95 | 26-7/8 | 683 | |

SETTING THE UNIT (Continued) – Unit Placement

NOTICE!

Roof Damage!

This system contains both refrigerant and oil. Some rubber roofing material may absorb oil, causing the rubber to degrade. Failure to follow this notice could result in damage to roof surface.

! IMPORTANT

This unit must be matched with an indoor coil as specified with AHRI. For AHRI Certified system match-ups and expanded ratings, visit www.LennoxPros.com. Coils previously charged with HCFC-22 must be flushed.

⚠️ WARNING

To prevent personal injury, as well as damage to panels, unit or structure, observe the following:

While installing or servicing this unit, carefully stow all removed panels so that the panels will not cause injury to personnel, objects or nearby structures. Also, take care to store panels where they will not be subject to damage (e.g., being bent or scratched).

While handling or stowing the panels, consider any weather conditions (especially wind) that may cause panels to be blown around and damaged.

⚠️ IMPORTANT

Exhaust vents from dryers, water heaters and furnaces should be directed away from the outdoor unit. Prolonged exposure to exhaust gases and the chemicals contained within them may cause condensation to form on the steel cabinet and other metal components of the outdoor unit. This will diminish unit performance and longevity.

PLACEMENT

INSTALL UNIT AWAY FROM WINDOWS.

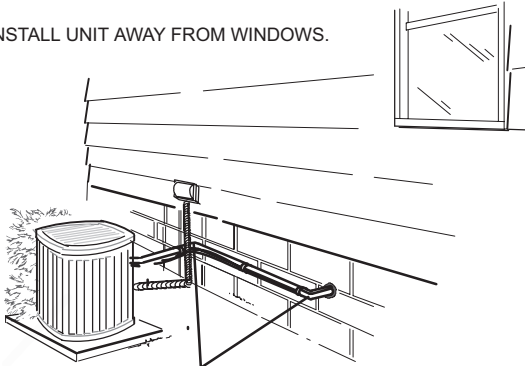

TWO 90° ELBOWS INSTALLED IN LINE SET WILL REDUCE LINE SET VIBRATION.

FIGURE 1

SLAB MOUNTING

Install unit level or, if on a slope, maintain slope tolerance of 2 degrees (or 2 inches per 5 feet [50 mm per 1.5 m]) away from building structure.

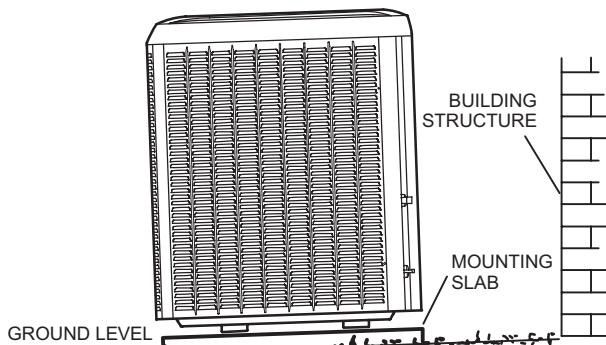
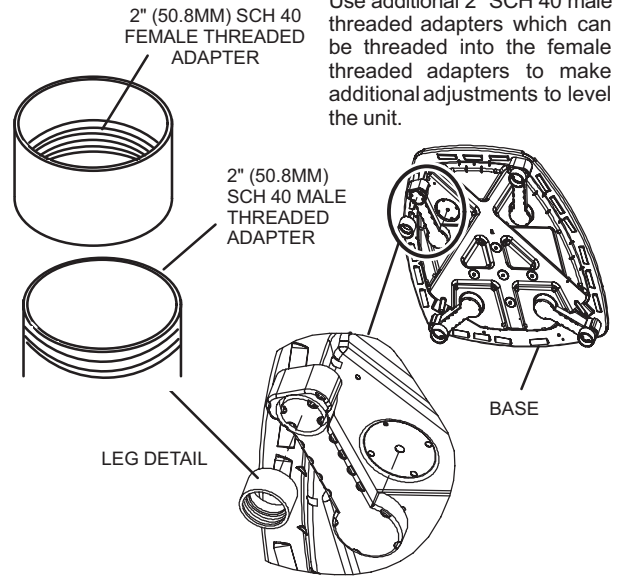

FIGURE 2

ELEVATED SLAB MOUNTING USING FEET EXTENDERS



Use additional 2" SCH 40 male threaded adapters which can be threaded into the female threaded adapters to make additional adjustments to level the unit.

FIGURE 3

STABILIZING UNIT ON UNEVEN SURFACES

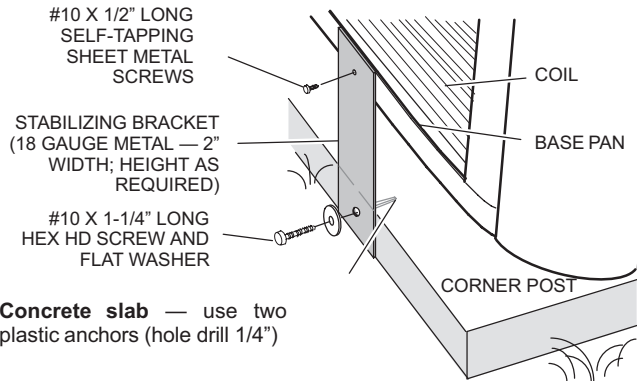

Concrete slab — use two plastic anchors (hole drill 1/4")

IMPORTANT !

Unit Stabilizer Bracket Use (field-provided):

Always use stabilizers when unit is raised above the factory height. (Elevated units could become unstable in gusty wind conditions.) Stabilizers may be used on any unit installed on unstable and uneven surfaces.

FIGURE 4

REFRIGERANT PIPING

IMPORTANT

If this unit is being matched with an approved line set or indoor unit coil that was previously charged with mineral oil, or if it is being matched with a coil which was manufactured before January of 1999, the coil and line set must be flushed prior to installation. Take care to empty all existing traps. Polyvinyl ether (PVE) oils are used in Lennox variable-capacity units charged with HFC-410A refrigerant. Residual mineral oil can act as an insulator, preventing proper heat transfer. It can also clog the expansion device and reduce system performance and capacity. Failure to properly flush the system per this instruction and the detailed Installation and Service Procedures manual will void the warranty.

Flush the existing line set per the following instructions. For more information, refer to the Installation and Service Procedures manual available on LennoxPros.com. CAUTION - DO NOT attempt to flush and re-use existing line sets or indoor coil when the system contains contaminants (i.e., compressor burn out).

Polyvinyl ether (PVE) oil is used in the EL18XCV compressors. For installations of the EL18XCV unit with refrigerant lines or coils previously charged with R410A and POE oil, Lennox recommends flushing the existing lines and coil with R410A refrigerant to remove excess POE oil that may be in the system.

If a new line set is being installed, size the piping per table 1.

TABLE 1

| REFRIGERANT LINE SET – INCHES (MM) | | | | | |
|------------------------------------|-------------------------|----------------------|----------------------|----------------------|---|
| Model | Valve Field Connections | | Recommended Line Set | | |
| | Liquid Line | Vapor Line | Liquid Line | Vapor Line | L15 Line Sets |
| -024 | 3/8 in. (10 mm) | 3/4 in. (19 mm) | 3/8 in. (10 mm) | 3/4 in. (19 mm) | L15-41 15 ft. - 50 ft. (4.6 m - 15 m) |
| -036 | 3/8 in. (10 mm) | 7/8 in. (22 mm) | 3/8 in. (10 mm) | 7/8 in. (22 mm) | L15-65 15 ft. - 50 ft. (4.6 m - 15 m) |
| -048 | | | | | |
| -060 | 3/8 in. (10 mm) | 1-1/8 in. (28 mm) | 3/8 in. (10 mm) | 1-1/8 in. (28 mm) | Field Fabricated |

NOTE - Some applications may require a field-provided 7/8" to 1-1/8" adapter.

NOTE - When installing refrigerant lines longer than 50 feet, refer to the Refrigerant Piping Design and Fabrication Guidelines manual available on LennoxPros.com (Corp. 9351-L9), or contact the Technical Support Department Product Application group for assistance.

NOTE - For new or replacement line set installation, refer to Service and Application Note - Corp. 9112-L4 (C-91-4).

WARNING



When using a high pressure gas such as nitrogen to pressurize a refrigeration or air conditioning system, use a regulator that can control the pressure down to 1 or 2 psig (6.9 to 13.8 kPa).

WARNING

Refrigerant can be harmful if it is inhaled. Refrigerant must be used and recovered responsibly.

Failure to follow this warning may result in personal injury or death.

WARNING



Fire, Explosion and Personal Safety hazard. Failure to follow this warning could result in damage, personal injury or death.

Never use oxygen to pressurize or purge refrigeration lines. Oxygen, when exposed to a spark or open flame, can cause fire and/or an explosion, that could result in property damage, personal injury or death.

WARNING

Polyvinyl ether (PVE) oils used with HFC-410A refrigerant absorb moisture very quickly. It is very important that the refrigerant system be kept closed as much as possible. DO NOT remove line set caps or service valve stub caps until you are ready to make connections.

IMPORTANT

Some 5-ton units use scroll compressors equipped with an internal vacuum protector that will unload scrolls when suction pressure goes below 20 psig. A hissing sound will be heard when the compressor is running unloaded. Protector will reset when low pressure in system is raised above 40 psig. DO NOT REPLACE COMPRESSOR.

The EL18XCV is a variable-capacity cooling system utilizing variable speed compressor technology. With the variable speed compressor and variable pumping capacity, additional consideration must be given to refrigerant piping sizing and application. The guidelines below are to be used exclusively for the EL18XCV systems.

COOLING SYSTEM (HFC410A)

- Total equivalent length equals 180 feet (piping and all fittings included).

NOTE – Length is general guide. Lengths may be more or less, depending on remaining system design factors.

- Maximum linear (actual) length = 150 feet.
- Maximum linear liquid lift = 60 feet.

NOTE – Maximum lifts are dependent on total length, number of elbows, etc. that contribute to total pressure drop.

- Maximum length vapor riser = 60 feet.
- **Up to 50 Linear Feet:** Use rated line sizes listed in table 1.
- **Between 51 and 150 Linear Feet:** Crankcase heater and nonbleed port TXV factory installed. No additional components required. Vertical vapor riser must be sized to the vapor riser listed in the table 2 on systems with

line sets longer than 51 feet. Use tables 2 and 3 to determine the correct liquid and vapor line sizes.

- **Over 150 Linear Feet:** not recommended.
- Additional oil is not required for systems with line lengths up to 150 feet.

SUCTION TRAPS

For systems with the outdoor unit 5 - 60 feet above the indoor unit, one trap must be installed at the bottom of the suction riser.

TABLE 2. Standard Refrigerant Line Set – Up to 50 Linear Feet in Length

| Inches (mm) | | | | | |
|----------------------------------|------------------------|-------------------|-----------------------|------------------|----------------|
| EL18XCV* | Valve Size Connections | | Recommended Line Sets | | |
| | Liquid Line | Suction Line | L15 Line Set Model | Line Set Length | Catalog Number |
| -024, S024 | 3/8" (10 mm) | 3/4" (19 mm) | L15-41-30 | 30 feet (9.1 m) | 89J60 |
| -036, S036 -048, S048 | 3/8" (10 mm) | 7/8" (22 mm) | L15-65-40 | 40 feet (12.2 m) | 89J61 |
| | | | L15-65-50 | 50 feet (15.2 m) | 89J62 |
| -060, S060 | 3/8" (10 mm) | 1-1/8" (29 mm) ** | Field-fabricated | | |

* Applicable to all minor revision numbers unless otherwise specified.
 ** Some applications may require a field-provided 1-1/8" to 7/8" adapter.

TABLE 3. EL18XCV Line Set Guidelines – 51 to 150 Linear Feet in Length

| Model | Maximum Total Equivalent Length (ft) | Maximum Linear (actual) Length (ft) | Maximum Vapor Riser (ft) | Maximum Linear Liquid Lift (ft) | Preferred Vapor Line Sizes for Horizontal Runs | Required Vapor Riser Size |
|-------|--------------------------------------|-------------------------------------|--------------------------|---------------------------------|--|---------------------------|
| -024 | 180 | 150 | 60 | 60 | 7/8" | 5/8" |
| -036 | 180 | 150 | 60 | 60 | 7/8" | 3/4" |
| -048 | 180 | 150 | 60 | 60 | 7/8" | 7/8" |
| -060 | 180 | 150 | 60 | 60 | 7/8" | 7/8" |

TABLE 4. Liquid Line Diameter Selection Table

| Unit | Line Size | Total Linear Length (feet) | | | | | | Max. Elevation (ft) |
|------|-----------|----------------------------|----|----|-----|-----|-----|---------------------|
| | | 25 | 50 | 75 | 100 | 125 | 150 | |
| -024 | 5/16" | 25 | 50 | 55 | 48 | 40 | 33 | |
| | 3/8" | 25 | 50 | 60 | 60 | 60 | 60 | |
| -036 | 3/8" | 25 | 50 | 60 | 56 | 51 | 45 | |
| | 1/2" | 25 | 50 | 60 | 60 | 60 | 60 | |
| -048 | 3/8" | 25 | 50 | 50 | 41 | 31 | 22 | |
| | 1/2" | 25 | 50 | 60 | 60 | 60 | 60 | |
| -060 | 3/8" | 25 | 50 | 36 | 22 | 8 | NR | |
| | 1/2" | 25 | 50 | 60 | 60 | 60 | 59 | |

NOTE - Shaded rows indicate rated liquid line size

- Find your unit on the left side of the table.
- Start with the rated liquid line size (shaded row) on the outdoor unit
- Select the actual Total Linear Length of your system shown at the top of the table.
- The elevation listed in the table is the maximum allowed for the liquid line listed.
- Select or consider the larger liquid line size shown in the table if the elevation does not meet your requirements.

NOTE - For new or replacement line set installation, refer to Service and Application Note - Corp. 9112-L4 (C-91-4).

REFRIGERANT PIPING – Removing Existing Indoor Metering Device

1A TYPICAL EXISTING FIXED ORIFICE REMOVAL PROCEDURE (UNCASED COIL SHOWN)

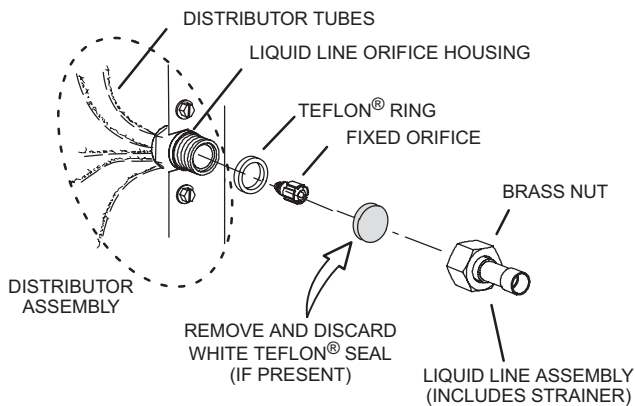

- A - On fully cased coils, remove the coil access and plumbing panels.
- B - Remove any shipping clamps from the liquid line and distributor assembly.
- C - Using two wrenches, disconnect liquid line from liquid line orifice housing. Take care not to twist or damage distributor tubes during this process.
- D - Remove and discard fixed orifice, valve stem assembly (if present) and Teflon® washer as illustrated above.
- E - Use a field-provided fitting to temporarily reconnect the liquid line to the indoor unit's liquid line orifice housing.

OR 1B TYPICAL EXISTING EXPANSION VALVE REMOVAL PROCEDURE (UNCASED COIL SHOWN)

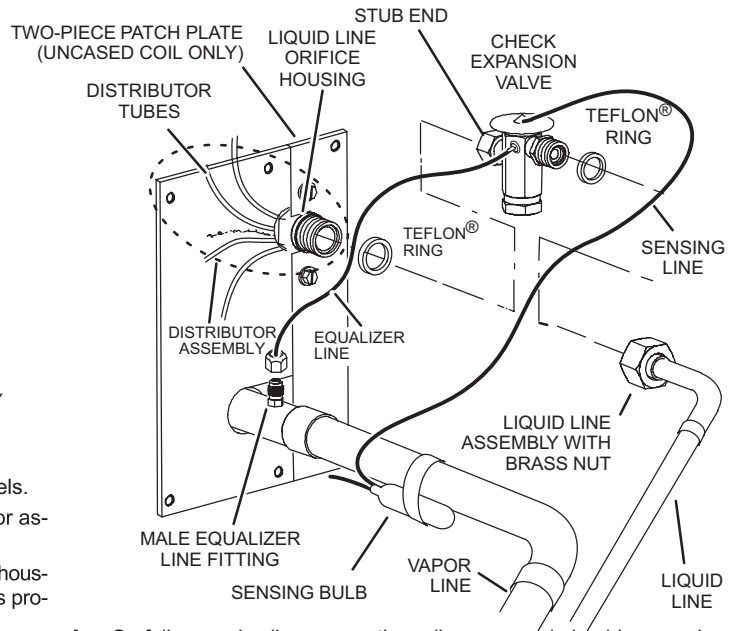

- A - On fully cased coils, remove the coil access and plumbing panels.
- B - Remove any shipping clamps from the liquid line and distributor assembly.
- C - Disconnect the equalizer line from the check expansion valve equalizer line fitting on the vapor line.
- D - Remove the vapor line sensing bulb.
- E - Disconnect the liquid line from the check expansion valve at the liquid line assembly.
- F - Disconnect the check expansion valve from the liquid line orifice housing. Take care not to twist or damage distributor tubes during this process.
- G - Remove and discard check expansion valve and the two Teflon® rings.
- H - Use a field-provided fitting to temporarily reconnect the liquid line to the indoor unit's liquid line orifice housing.

2 CONNECT GAUGES AND EQUIPMENT FOR FLUSHING PROCEDURE

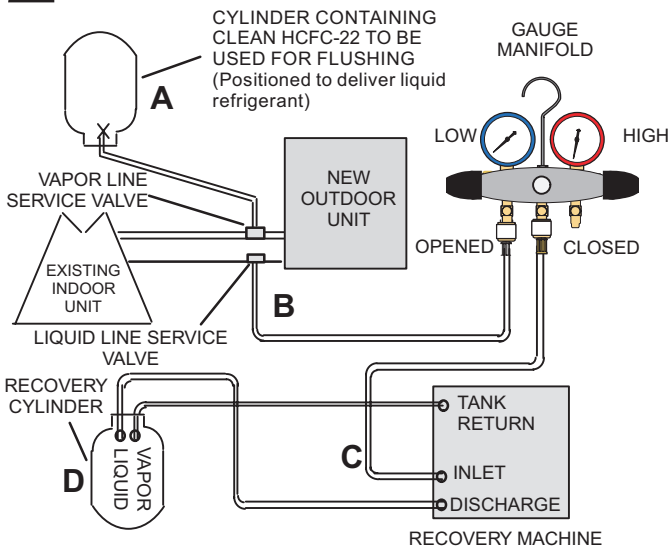

- A - HCFC-22 cylinder with clean refrigerant (positioned to deliver liquid refrigerant) to the vapor service valve.
- B - HCFC-22 gauge set (low side) to the liquid line valve.
- C - HCFC-22 gauge set center port to inlet on the recovery machine with an empty recovery tank connected to the gauge set.
- D - Connect recovery tank to recovery machine per machine instructions.

3 FLUSHING LINE SET

The line set and indoor unit coil must be flushed with at least the same amount of clean refrigerant that previously charged the system. Check the charge in the flushing cylinder before proceeding.

- A - Set the recovery machine for liquid recovery and start the recovery machine. Open the gauge set valves to allow the recovery machine to pull a vacuum on the existing system line set and indoor unit coil.
- B - Position the cylinder of clean HCFC-22 for delivery of liquid refrigerant and open its valve to allow liquid refrigerant to flow into the system through the vapor line valve. Allow the refrigerant to pass from the cylinder and through the line set and the indoor unit coil before it enters the recovery machine.
- C - After all of the liquid refrigerant has been recovered, switch the recovery machine to vapor recovery so that all of the HCFC-22 vapor is recovered. Allow the recovery machine to pull the system down to 0.
- D - Close the valve on the inverted HCFC-22 drum and the gauge set valves. Pump the remaining refrigerant out of the recovery machine and turn the machine off.

FIGURE 5

REFRIGERANT PIPING – Brazing Procedures

1 CUT AND DEBUR

Cut ends of the refrigerant lines square (free from nicks or dents) and debur the ends. The pipe must remain round. Do not crimp end of the line.

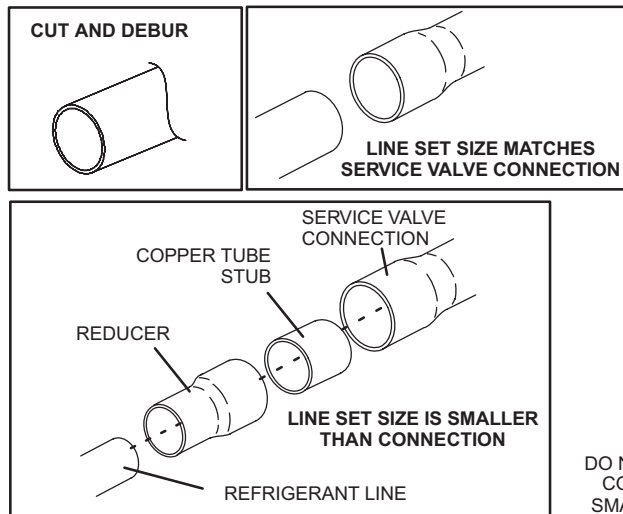

2 CAP AND CORE REMOVAL

Remove service cap and core from both the vapor and liquid line service ports.

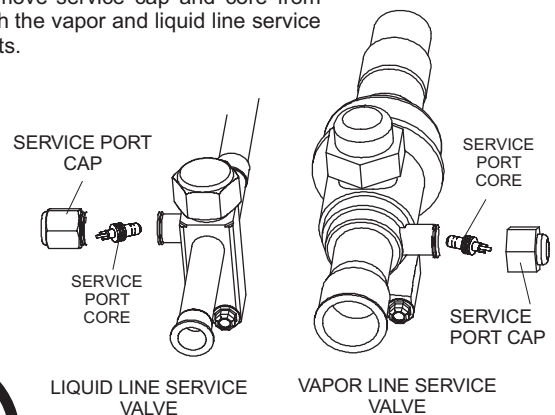

3 ATTACH THE MANIFOLD GAUGE SET FOR BRAZING LIQUID AND VAPOR LINE SERVICE VALVES

Flow regulated nitrogen (at 1 to 2 psig) through the low-side refrigeration gauge set into the liquid line service port valve, and out of the vapor line service port valve.

- A - Connect gauge set low pressure side to liquid line service valve (service port).
- B - Connect gauge set center port to bottle of nitrogen with regulator.
- C - Remove core from valve in vapor line service port to allow nitrogen to escape.

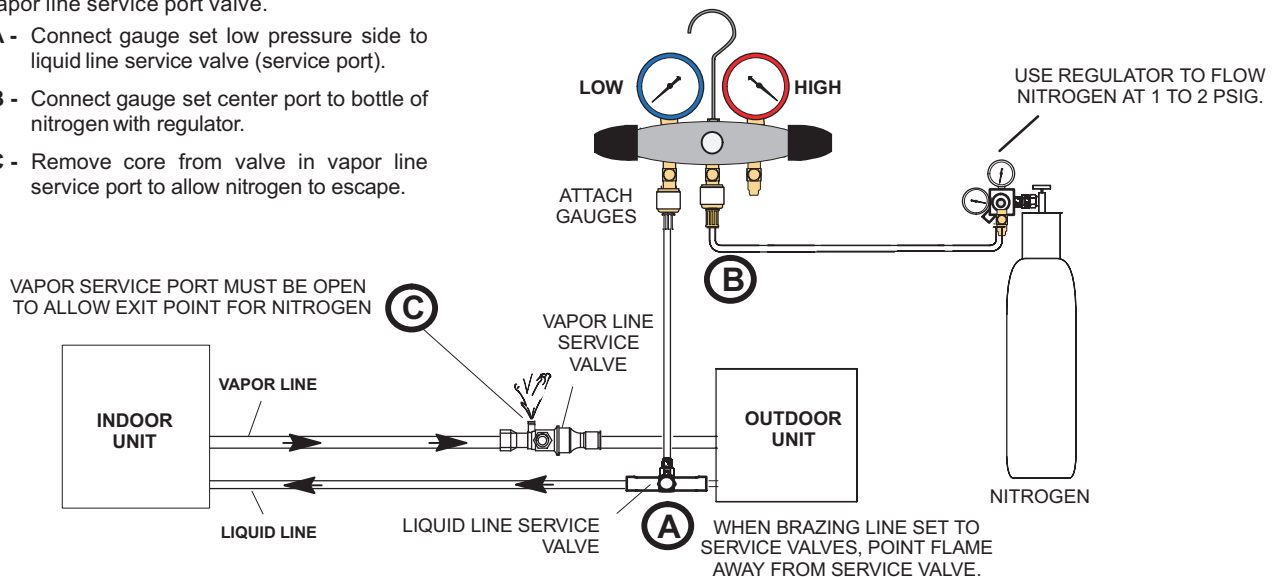

FIGURE 6

⚠ CAUTION

Brazing alloys and flux contain materials which are hazardous to your health. Avoid breathing vapors or fumes from brazing operations. Perform operations only in well-ventilated areas. Wear gloves and protective goggles or face shield to protect against burns. Wash hands with soap and water after handling brazing alloys and flux.

⚠ WARNING



Danger of fire. Bleeding the refrigerant charge from only the high side may result in pressurization of the low side shell and suction tubing. Application of a brazing torch to a pressurized system may result in ignition of the refrigerant and oil mixture. Check the high and low pressures before applying heat.

4 WRAP SERVICE VALVES

To help protect service valve seals during brazing, wrap water-saturated cloths around service valve bodies and copper tube stubs. Use additional water-saturated cloths underneath the valve body to protect the base paint.

5 FLOW NITROGEN

Flow regulated nitrogen (at 1 to 2 psig) through the refrigeration gauge set into the valve stem port connection on the liquid service valve and out of the vapor valve stem port. See steps 3A, 3B and 3C on manifold gauge set connections.

6 BRAZE LINE SET

Wrap both service valves with water-saturated cloths as illustrated here and as mentioned in step 4, before brazing to line set. Cloths must remain water-saturated throughout the brazing and cool-down process.

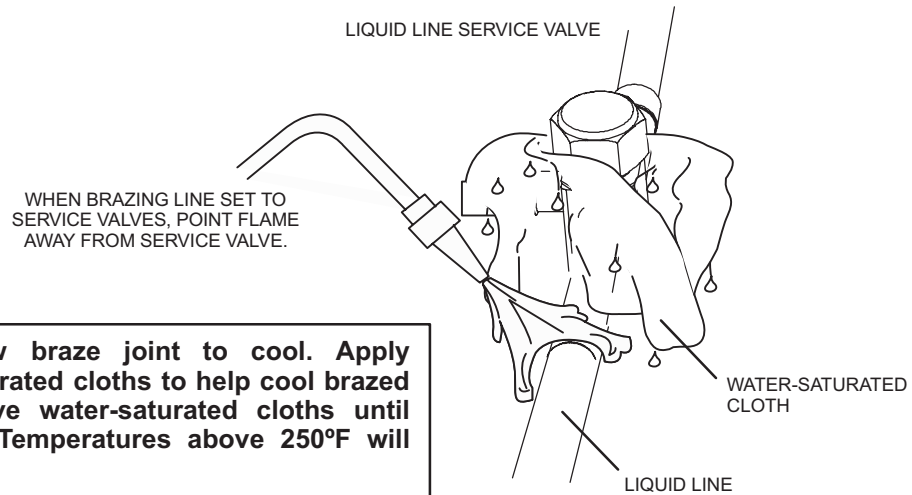

IMPORTANT — Allow braze joint to cool. Apply additional water-saturated cloths to help cool brazed joint. Do not remove water-saturated cloths until piping has cooled. Temperatures above 250°F will damage valve seals.

WARNING



FIRE, PERSONAL INJURY, OR PROPERTY DAMAGE may result if you do not wrap a water-saturated cloth around both liquid and suction line service valve bodies and copper tube stub while brazing the line set! The braze, when complete, must be quenched with water to absorb any residual heat.



Do not open service valves until refrigerant lines and indoor coil have been leak-tested and evacuated. Refer to Installation and Service Procedures manual found on LennoxPros.com.

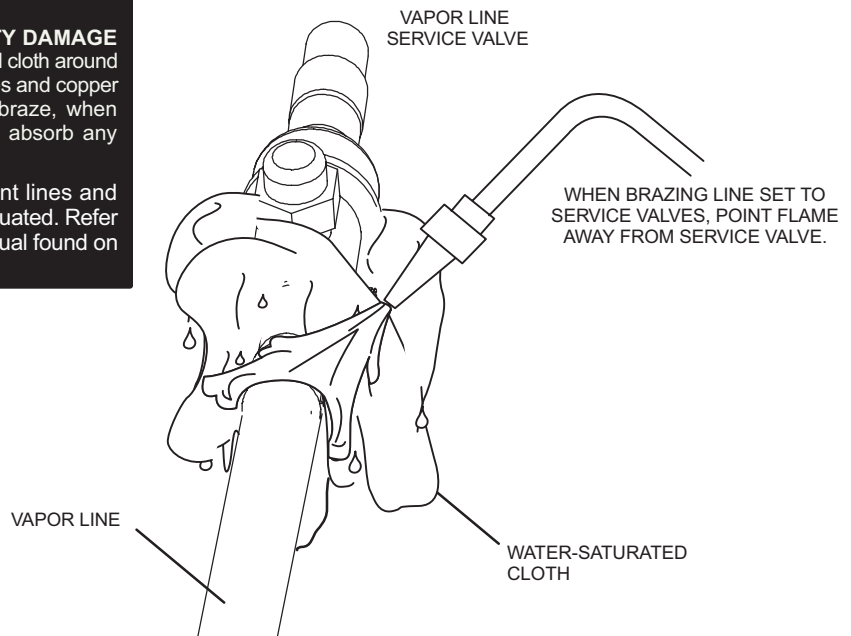

7 PREPARATION FOR NEXT STEP

After all connections have been brazed, disconnect manifold gauge set from service ports. Apply additional water-saturated cloths to both services valves to cool piping. Once piping is cool, remove all water-saturated cloths.

FIGURE 7

REFRIGERANT PIPING – Install Indoor Expansion Valve

This outdoor unit is designed for use in systems that include an expansion valve metering device (purchased separately) at the indoor coil. See the EL18XCV Product Specifications bulletin (EHB) for approved expansion valve kit match-ups and application information. The expansion valve unit can be installed internal or external to the indoor coil. In applications where an uncased coil is being installed in a field-provided plenum, install the expansion valve in a manner that will provide access for future field service of the expansion valve. Refer to below illustration for reference during installation of expansion valve unit.

INDOOR EXPANSION VALVE INSTALLATION

(Uncased Coil Shown)

Labels in diagram: TWO PIECE PATCH PLATE (UNCASED COIL ONLY), DISTRIBUTOR TUBES, DISTRIBUTOR ASSEMBLY, MALE EQUALIZER LINE FITTING (SEE EQUALIZER LINE INSTALLATION FOR FURTHER DETAILS), LIQUID LINE ORIFICE HOUSING, STUB END, CHECK EXPANSION VALVE, TEFLON® RING, SENSING LINE, EQUALIZER LINE, LIQUID LINE ASSEMBLY WITH BRASS NUT, VAPOR LINE, LIQUID LINE.

Sensing bulb insulation is required if mounted external to the coil casing. sensing bulb installation for bulb positioning.

- 3 - Install one of the provided Teflon® rings around the stubbed end of the check expansion valve and lightly lubricate the connector threads and expose surface of the Teflon® ring with refrigerant oil.
- 4 - Attach the stubbed end of the check expansion valve to the liquid line orifice housing. Finger tighten and use an appropriately sized wrench to turn an additional 1/2 turn clockwise as illustrated in the figure above, or tighten to 20 ft-lb.
- 5 - Place the remaining Teflon® washer around the other end of the check expansion valve. Lightly lubricate connector threads and expose surface of the Teflon® ring with refrigerant oil.
- 6 - Attach the liquid line assembly to the check expansion valve. Finger tighten and use an appropriately sized wrench to turn an additional 1/2 turn clockwise as illustrated in the figure above or tighten to 20 ft-lb.

EQUALIZER LINE INSTALLATION

- 1 - Remove and discard either the flare seal cap or flare nut with copper flare seal bonnet from the equalizer line port on the vapor line as illustrated in the figure below.
- 2 - Remove the field-provided fitting that temporarily reconnected the liquid line to the indoor unit's distributor assembly.

Labels in diagram: FLARE SEAL CAP, FLARE NUT, COPPER FLARE SEAL BONNET, MALE BRASS EQUALIZER LINE FITTING, VAPOR LINE.

SENSING BULB INSTALLATION

- 1 - Attach the vapor line sensing bulb in the proper orientation as illustrated below using the clamp and screws provided.

ON LINES SMALLER THAN 3/4", MOUNT SENSING BULB AT EITHER THE 1 OR 11 O'CLOCK POSITION.

ON 3/4" AND LARGER LINES, MOUNT SENSING BULB AT EITHER THE 3 OR 9 O'CLOCK POSITION.

NOTE - NEVER MOUNT THE SENSING BULB ON BOTTOM OF LINE.

NOTE - Though it is preferred to have the sensing bulb installed on a horizontal run of the vapor line, installation on a vertical run of piping is acceptable if necessary. See figure to right for proper bulb orientation on vertical run of piping.

NOTE - Confirm proper thermal contact between vapor line and check/expansion bulb before insulating the sensing bulb once installed.

- 2 - Connect the equalizer line from the check expansion valve to the equalizer vapor port on the vapor line. Finger tighten the flare nut plus 1/8 turn (7 ft-lbs) as illustrated to the right.

FIGURE 8

LEAK TEST AND EVACUATION

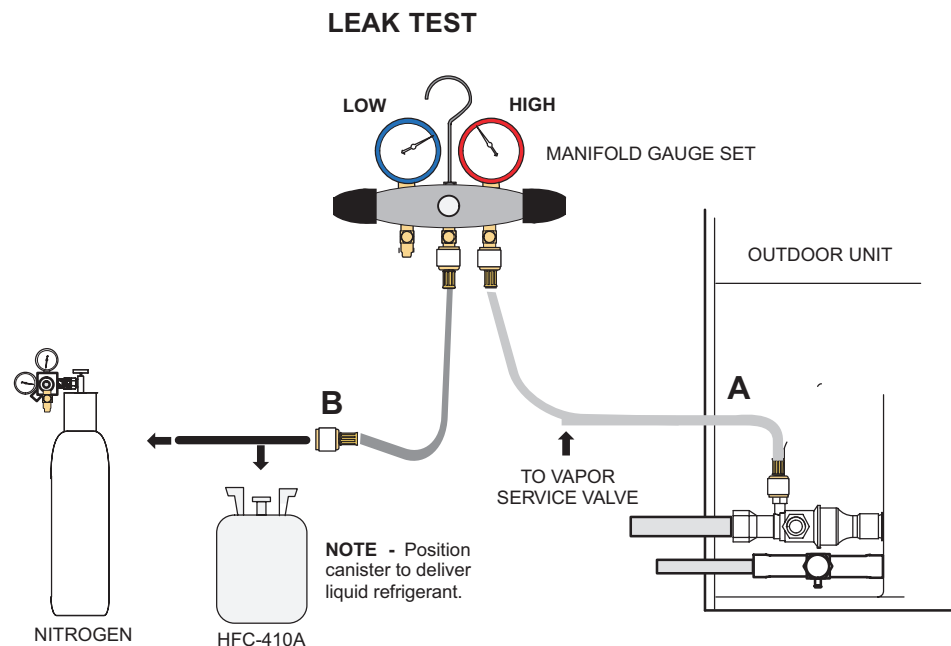

1 CONNECT GAUGE SET

A - Connect the high pressure hose of an HFC-410A manifold gauge set to the vapor valve service port.

NOTE - Normally, the high pressure hose is connected to the liquid line port. However, connecting it to the vapor port better protects the manifold gauge set from high pressure damage.

B - With both manifold valves closed, connect the cylinder of HFC-410A refrigerant to the center port of the manifold gauge set.

NOTE - Later in the procedure, the HFC-410A container will be replaced by the nitrogen container.

2 TEST FOR LEAKS

After the line set has been connected to the indoor and outdoor units, check the line set connections and indoor unit for leaks. Use the following procedure to test for leaks:

A - With both manifold valves closed, connect the cylinder of HFC-410A refrigerant to the center port of the manifold gauge set. Open the valve on the HFC-410A cylinder (vapor only).

B - Open the high pressure side of the manifold to allow HFC-410A into the line set and indoor unit. Weigh in a trace amount of HFC-410A. [A trace amount is a maximum of two ounces (57 g) refrigerant or three pounds (31 kPa) pressure.] Close the valve on the HFC-410A cylinder and the valve on the high pressure side of the manifold gauge set. Disconnect the HFC-410A cylinder.

C - Connect a cylinder of nitrogen with a pressure regulating valve to the center port of the manifold gauge set.

D - Adjust nitrogen pressure to 150 psig (1034 kPa). Open the valve on the high side of the manifold gauge set in order to pressurize the line set and the indoor unit.

E - After a few minutes, open one of the service valve ports and verify that the refrigerant added to the system earlier is measurable with a leak detector.

F - After leak testing, disconnect gauges from service ports.

FIGURE 9

3 CONNECT GAUGE SET

NOTE - Remove cores from service valves (if not already done).

- A - Connect low side of manifold gauge set with 1/4 SAE in-line tee to vapor line service valve
- B - Connect high side of manifold gauge set to liquid line service valve
- C - Connect available micron gauge connector on the 1/4 SAE in-line tee.
- D - Connect the vacuum pump (with vacuum gauge) to the center port of the manifold gauge set. The center port line will be used later for both the HFC-410A and nitrogen containers.

NOTE - Position canister to deliver liquid refrigerant.

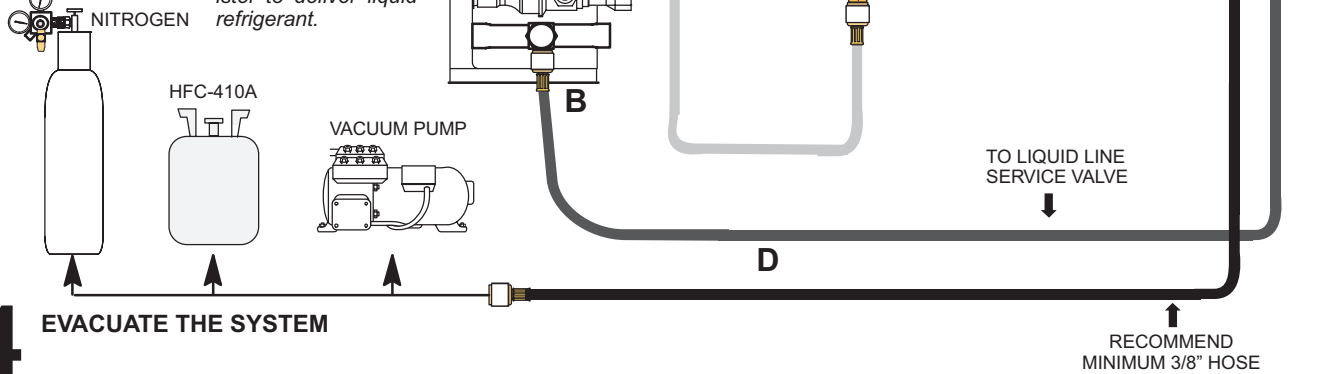

4 EVACUATE THE SYSTEM

- A - Open both manifold valves and start the vacuum pump.
- B - Evacuate the line set and indoor unit to an **absolute pressure** of 23,000 microns (29.01 inches of mercury).
 - NOTE** - During the early stages of evacuation, it is desirable to close the manifold gauge valve at least once. A rapid rise in pressure indicates a relatively large leak. If this occurs, **repeat the leak testing procedure**.
 - NOTE** - The term **absolute pressure** means the total actual pressure above absolute zero within a given volume or system. Absolute pressure in a vacuum is equal to atmospheric pressure minus vacuum pressure.
- C - When the absolute pressure reaches 23,000 microns (29.01 inches of mercury), perform the following:
 - Close manifold gauge valves.
 - Close valve on vacuum pump.
 - Turn off vacuum pump.
 - Disconnect manifold gauge center port hose from vacuum pump.
 - Attach manifold center port hose to a nitrogen cylinder with pressure regulator set to 150 psig (1034 kPa) and purge the hose.
 - Open manifold gauge valves to break the vacuum in the line set and indoor unit.
 - Close manifold gauge valves.
- D - Shut off the nitrogen cylinder and remove the manifold gauge hose from the cylinder. Open the manifold gauge valves to release the nitrogen from the line set and indoor unit.
- E - Reconnect the manifold gauge to the vacuum pump, turn the pump on, and continue to evacuate the line set and indoor unit until the absolute pressure does not rise above 500 microns (29.9 inches of mercury) within a 20-minute period after shutting off the vacuum pump and closing the manifold gauge valves.
- F - When the absolute pressure requirement above has been met, disconnect the manifold hose from the vacuum pump and connect it to a cylinder of HFC-410A positioned to deliver liquid refrigerant. Open the manifold gauge valve 1 to 2 psig in order to release the vacuum in the line set and indoor unit.
- G - Perform the following:
 - Close manifold gauge valves.
 - Shut off HFC-410A cylinder.
 - Reinstall service valve cores by removing manifold hose from service valve. Quickly install cores with core tool while maintaining a positive system pressure.
 - Replace stem caps and finger tighten them, then tighten an additional one-sixth (1/6) of a turn as illustrated.

WARNING !

Possible equipment damage.

Avoid deep vacuum operation. Do not use compressors to evacuate a system. Extremely low vacuum can cause internal arcing and compressor failure. Damage caused by deep vacuum operation will void warranty.

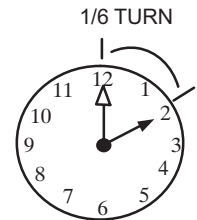

FIGURE 10

ELECTRICAL – Circuit Sizing and Wire Routing

In the U.S.A., wiring must conform with current local codes and the current National Electric Code (NEC). In Canada, wiring must conform with current local codes and the current Canadian Electrical Code (CEC).

Refer to the furnace or air handler installation instructions for additional wiring application diagrams and refer to unit nameplate for minimum circuit ampacity and maximum overcurrent protection size.

24VAC TRANSFORMER

Use the transformer provided with the furnace or air handler for low-voltage control power (24VAC - 40 VA minimum).

Thermostat Control and Low Voltage Control Wiring

EL18XCV Thermostat Control Options

The EL18XCV variable capacity units provide two thermostat control options to provide application and installation flexibility.

S30 Communicating Thermostat Control

The EL18XCV variable capacity unit may be installed as a fully communicating system consisting of an S30 Communicating Thermostat, a communicating indoor unit and the EL18XCV variable capacity outdoor unit wired with (4) communication wires (R, I+, I- and C) connected to the EL18XCV Outdoor Unitary Control.

The EL18XCV variable capacity unit when wired as a fully communicating system will take full advantage of the advanced diagnostics and control, Wi-Fi accessibility and system operation parameters. Refer to the EL18XCV field wiring diagram for an S30 communicating thermostat.

Conventional 24VAC Non-Communicating Thermostat Control

The EL18XCV variable capacity unit may be installed using a conventional 24VAC non-communicating two-stage cooling or single-stage cooling thermostat.

NOTE – *The conventional 24VAC non-communicating thermostat must have a compressor minimum on time of three minutes to prevent compressor short cycling. The Lennox M30, ComfortSense 7500, ComfortSense 3000 and many other commercially available electronic thermostats provide this feature.*

The EL18XCV unit will provide full variable capacity operation when installed with a conventional 24VAC non-communicating two stage cooling or single-stage cooling thermostat. The EL18XCV outdoor control has advanced control algorithms using the EL18XCV suction pressure sensor to provide true variable capacity operation.

When utilizing a two-stage conventional 24VAC non-communicating thermostat, four wires are required to control the outdoor unit (R, C, Y1 and Y2). Refer to the EL18XCV field wiring diagram for a conventional 24VAC non-communicating 2-stage thermostat.

When utilizing a single conventional 24VAC non-communicating thermostat, three wires are required to control the outdoor unit (R, C, and Y1) and Y1 is jumpered to Y2 in the outdoor unit. Note that the published performance data is based upon the use of a two-stage thermostat. Refer to the EL18XCV field wiring diagram for a conventional 24VAC non-communicating single-stage thermostat.

EL18XCV Low Voltage Control Wiring Connections

The EL18XCV variable capacity units are provided with (2) RAST 6-Pin connections in the installation instruction bag for connecting the field low voltage control wiring to the EL18XCV harnesses in the low voltage control make-up box. One RAST 6-pin connector is labeled with terminals TST, DF, R, I+, I- and C. The second RAST 6-pin connector is labeled with terminals DS, O, Y1, Y2, L and W.

⚠ WARNING



Electric Shock Hazard. Can cause injury or death. Unit must be properly grounded in accordance with national and local codes.

Line voltage is present at all components when unit is not in operation on units with single-pole contactors. Disconnect all remote electric power supplies before opening access panel. Unit may have multiple power supplies.

⚠ WARNING

Fire Hazard. Use of aluminum wire with this product may result in a fire, causing property damage, severe injury or death. Use copper wire only with this product.

⚠ WARNING

Failure to use properly sized wiring and circuit breaker may result in property damage. Size wiring and circuit breaker(s) per Product Specifications bulletin (EHB) and unit rating plate.

⚠ WARNING

ELECTROSTATIC DISCHARGE (ESD)

Precautions and Procedures

Electrostatic discharge can affect electronic components. Take care during unit installation and service to protect the unit's electronic controls. Precautions will help to avoid control exposure to electrostatic discharge by putting the unit, the control and the technician at the same electrostatic potential. Touch hand and all tools on an unpainted unit surface before performing any service procedure to neutralize electrostatic charge.

EL18XCV Thermostat Control Options

| Thermostat Type | Indoor Unit Type | Qty. of Wires to EL18XCV | EL18XCV Terminal Strip Connections | Unit Operation | Field Wiring Diagram |
|--|---|--------------------------|------------------------------------|---|----------------------|
| S30 Communicating Thermostat | Communicating Gas Furnace or Air Handler | 4 | R, I+, I-, C | Fully Communicating Variable Capacity Operation Based Upon Thermostat Demand | Figure 13 |
| Conventional 24VAC 2-Stage Cooling Thermostat (non-communicating) | Any Furnace or Air Handler (non-communicating or communicating) | 4 | R, C, Y1, Y2 | Full Variable Capacity Operation Controlled by EL18XCV Unitary Control Using Suction Pressure | Figure 14 |
| Conventional 24VAC Single-Stage Cooling Thermostat (non-communicating) | Any Furnace or Air Handler (non-communicating or communicating) | 3 | R, C, Y1 (Jumper Y1 to Y2) | Full Variable Capacity Operation Controlled by EL18XCV Unitary Control Using Suction Pressure | Figure 14 |

1 SIZE CIRCUIT AND INSTALL SERVICE DISCONNECT SWITCH

Refer to the unit nameplate for minimum circuit ampacity, and maximum fuse or circuit breaker (HACR per NEC). Install power wiring and properly sized disconnect switch.

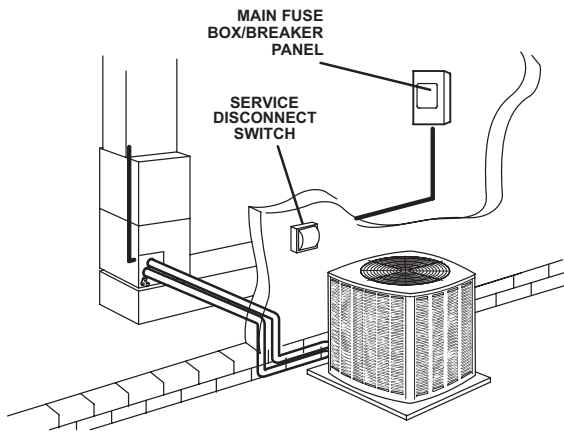

NOTE - Units are approved for use only with copper conductors. Ground unit at disconnect switch or connect to an earth ground.

2 INSTALL THERMOSTAT

Install room thermostat (ordered separately) on an inside wall approximately in the center of the conditioned area and 5 feet (1.5m) from the floor. It should not be installed on an outside wall or where it can be affected by sunlight or drafts.

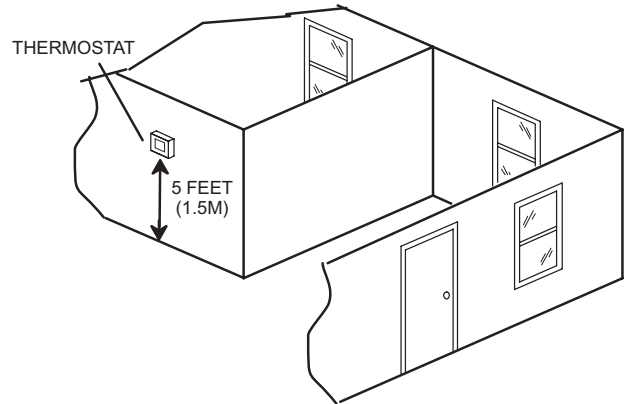

NOTE - 24VAC, Class II circuit connections are made in the control panel.

FIGURE 11

3 ROUTE CONTROL WIRES

iComfort Communicating Thermostat Wiring

Maximum length of wiring (18 gauge) for all connections on the RSBus is 1500 feet (457 meters). Wires should be color-coded, with a temperature rating of 95°F (35°C) minimum, and solid-core (Class II Rated Wiring). All low voltage wiring must enter unit through field-provided field-installed grommet installed in electrical inlet.

Conventional 24VAC Non-Communicating Thermostat Wiring

| WIRE RUN LENGTH | AWG# | INSULATION TYPE |
|----------------------------|------|--------------------|
| LESS THAN 100' (30 METERS) | 18 | TEMPERATURE RATING |
| MORE THAN 100' (30 METERS) | 16 | 35°C MINIMUM. |

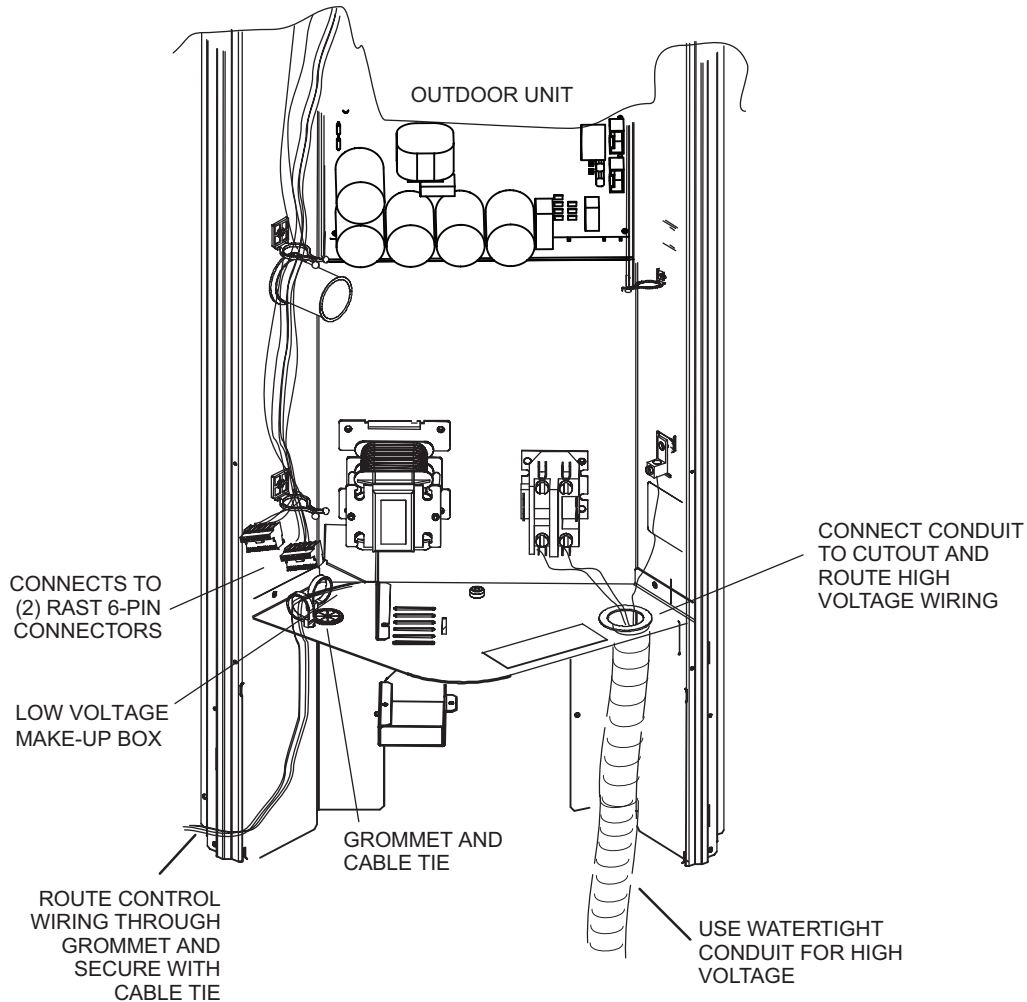

4 ROUTE HIGH VOLTAGE AND GROUND WIRES

Any excess high voltage field wiring should be trimmed and secured away from any low voltage field wiring. To facilitate a conduit, a cutout is located on the bottom of the control box. Connect conduit to the control box using a proper conduit fitting.

Connect the 208/230 high voltage power supply from the disconnect to the EL18XCV contactor as shown. Connect the ground wire from the power supply to the unit ground lug connection.

FIGURE 12

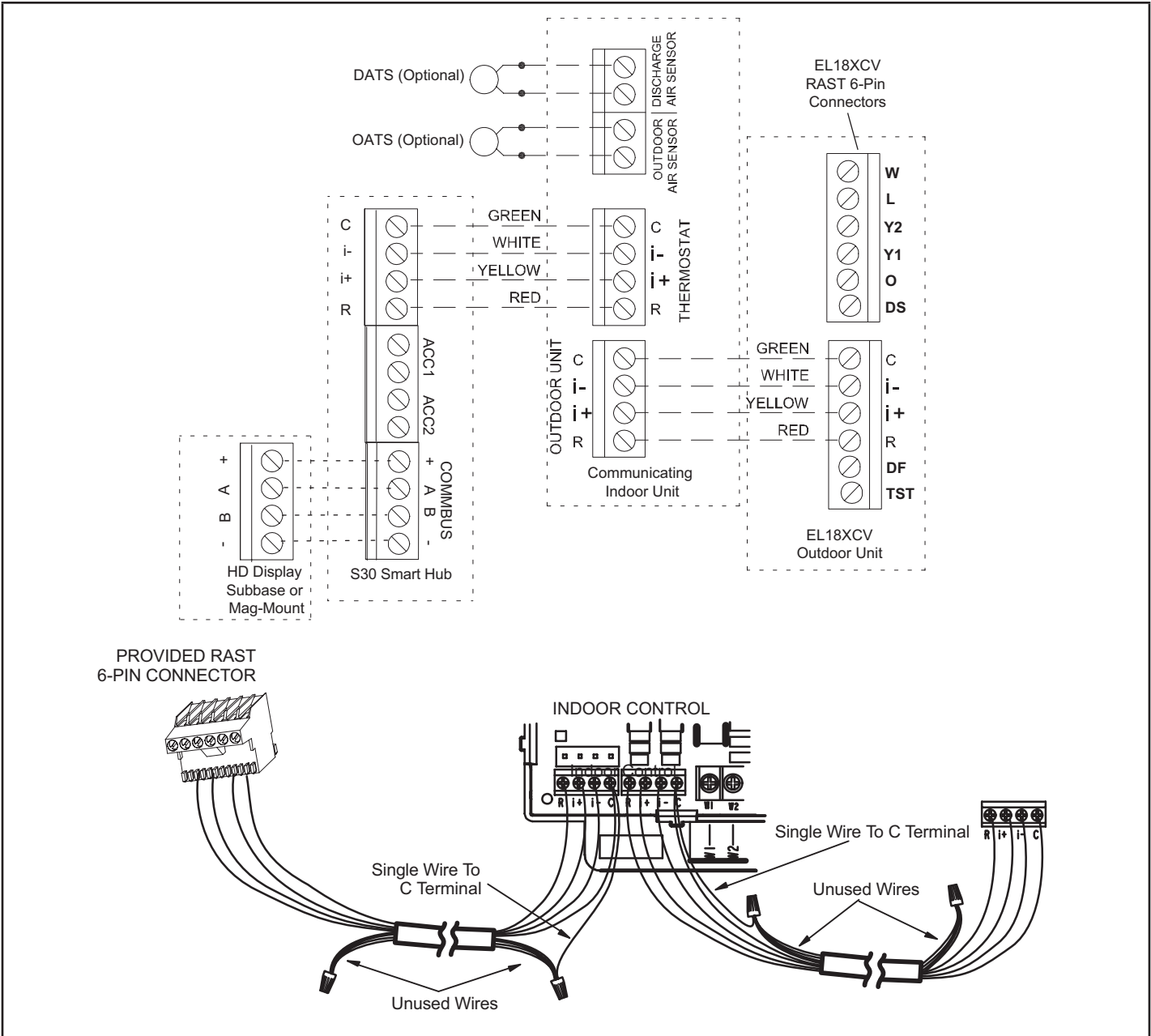
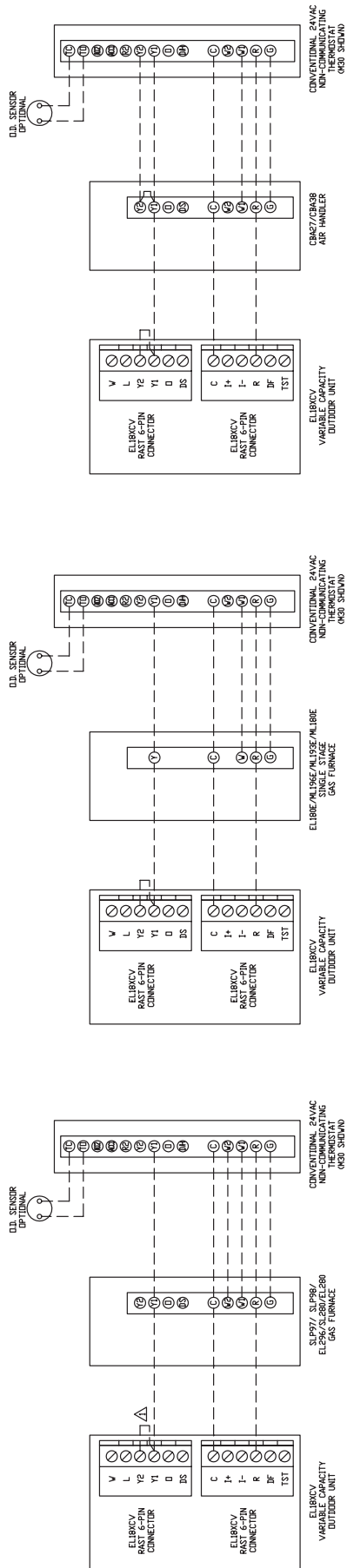

FIGURE 13. EL18XCV with S30 Communicating Thermostat – Field Wiring Diagram

SINGLE STAGE



△ FOR SINGLE STAGE COOLING,
INSTALL A JUMPER BETWEEN
Y1 TO Y2 ON THE EL18CV
TERMINAL STRIP

△ FOR SINGLE STAGE COOLING,
INSTALL A JUMPER BETWEEN
Y1 TO Y2 ON THE EL18CV
TERMINAL STRIP

△ FOR SINGLE STAGE COOLING,
INSTALL A JUMPER BETWEEN
Y1 TO Y2 ON THE EL18CV
TERMINAL STRIP

TWO STAGE

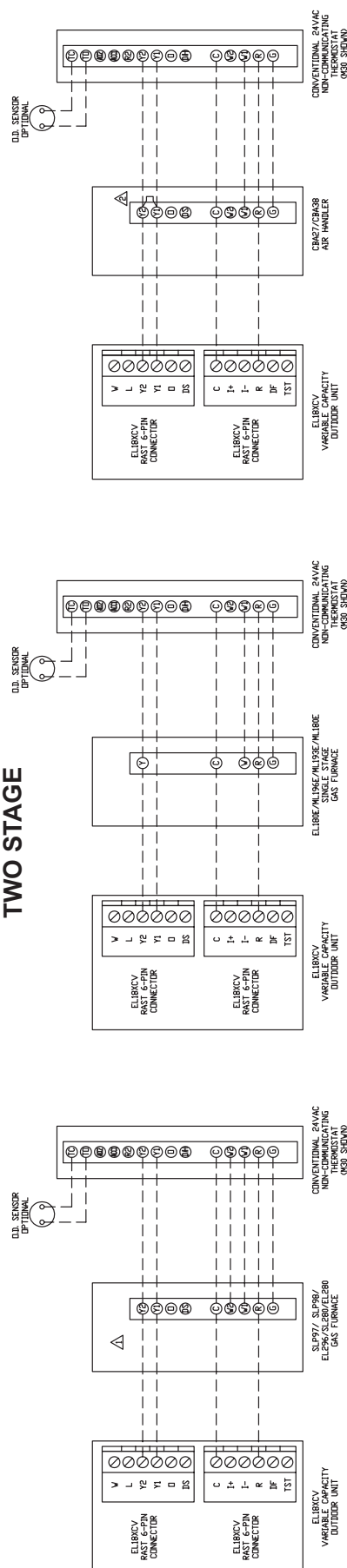

△ FOR 2-STAGE COOLING,
REMOVE THE Y1 TO Y2
JUMPER.

△ FOR 2-STAGE COOLING, **REMOVE** THE
Y1 TO Y2 JUMPER ON THE
O.D. BOARD LINK
(C/W15)

FIGURE 14. Conventional 24VAC Cooling Non-Communicating Thermostat Wiring

5 – Outdoor Unitary Control - Jumpers and Terminals

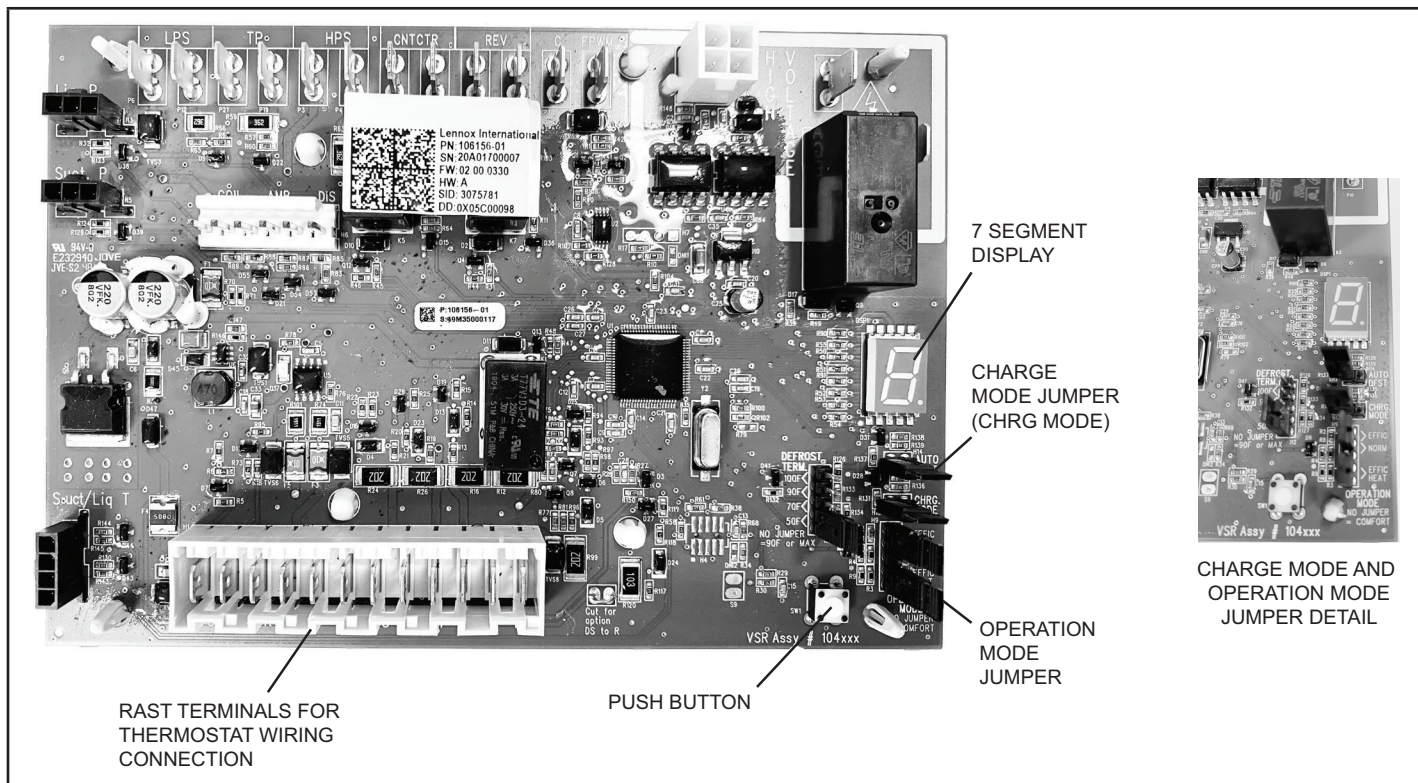

Outdoor Control 7 Segment Display and Push Button

Information concerning the outdoor control 7-segment display and push button operations are available on the unit access panel.

Alarms

Alarm information is provided on the unit access panel.

Charge Mode Jumper

To initiate the EL18XCV Charge Mode function, install the jumper across the two Charge Mode Pins (CHRG MODE) on the outdoor control. The Charge Mode can be used when charging the system with refrigerant, checking the refrigerant charge, pumping down the system and performing other service procedures that requires outdoor unit operation at 100% capacity.

EL18XCV Charge Mode Operation with a S30 Communicating Thermostat

Installing a jumper on the Charge Mode Pins will initiate compressor operation and outdoor fan motor at 100% capacity and will provide a signal to the indoor unit to initiate indoor blower operation at the maximum cooling air volume. To exit the charge mode, remove the Charge Mode Jumper. The Charge Mode has a maximum time of 60 minutes and will automatically exit the charge mode after 60 minutes is the charge mode jumper is left in place.

EL18XCV Charge Mode Operation with a Conventional 24VAC Non-Communicating Thermostat

On applications with a conventional 24VAC non-communicating thermostat, the charge mode jumper must be installed on the Charge Mode Pins after providing a Y1 cooling demand to the EL18XCV to initiate the Charge Mode. A cooling blower demand must also be provided to initiate blower operation on the cooling speed on the indoor unit. The compressor and outdoor fan motor will operate at 100% capacity. To exit the charging mode, remove the Charge Mode Jumper and remove the Y1 Cooling demand and indoor blower demand. The Charge Mode has a maximum time of 60 minutes and will automatically exit the charge mode after 60 minutes is the charge mode jumper is left in place.

Operation Mode Jumper

The Operation Mode Jumper is only used on applications installed with a conventional 24VAC Non-communicating thermostat. In applications with a conventional 24VAC non-communicating thermostat, the compressor capacity is controlled to maintain the target suction pressure setpoint. The Operation Mode Jumper has three selectable cooling modes. The three modes are Efficiency (Jumper installed on Pins 1 & 2), Normal Mode (Jumper installed on Pins 2 & 3) and Comfort Mode (Jumper Removed). The factory default position is the Efficiency Mode. The Efficiency mode has a variable suction pressure setpoint that will vary with the outdoor temperature; as the outdoor temperature increases the suction pressure setpoint will decrease. When the Operation Mode jumper is installed in the "Normal Mode" the suction pressure setpoint is 135 psig.

When the Operation Mode jumper is installed in the “Comfort Mode” the suction pressure setpoint is 125 psig.

Unit Operation

EL18XCV Unit Operation with a S30 Communicating Thermostat

When the EL18XCV unit is installed with a S30 Communicating Thermostat and a communicating indoor unit, the unit capacity will be controlled in the variable capacity mode throughout the range of capacity from minimum capacity to maximum capacity based upon thermostat demand. The indoor air volume will be controlled to match cooling capacity throughout the capacity range.

EL18XCV Unit Operation with a Conventional 24VAC Non-Communicating 2-Stage Thermostat

When the EL18XCV unit is installed with a conventional 24VAC non-communicating 2-stage thermostat, a Y1 first stage cooling demand will initiate cooling operation and first stage indoor blower operation. The compressor will be controlled in the variable capacity mode by varying the compressor capacity to obtain the target suction pressure set point. The Y2 second stage cooling demand will initiate second stage blower operation. Increased air volume will increase the load on the indoor coil and increase the suction pressure. The EL18XCV compressor capacity will continue to be controlled based upon the suction pressure. The unit capacity will be controlled in the variable capacity mode throughout the range of capacity from minimum capacity to maximum capacity. If the Y2 demand remains after 20 minutes, the EL18XCV control will begin to ramp up the compressor capacity until maximum capacity is achieved. The EL18XCV unit will cycle off once the thermostat demand is satisfied.

EL18XCV Unit Operation with a Conventional 24VAC Non-Communicating Single-Stage Thermostat

When the EL18XCV unit is installed with a conventional 24VAC non-communicating single-stage thermostat, a Y1 first stage cooling demand will initiate cooling operation and cooling indoor blower operation. In single stage thermostat applications, a jumper must be installed between Y1 and Y2 on the EL18XCV outdoor control. The compressor will be controlled in the variable capacity mode by varying the compressor capacity to obtain the target suction pressure set point. If the cooling demand remains after 20 minutes, the EL18XCV control will begin to ramp up the compressor capacity until maximum capacity is achieved. The EL18XCV unit will cycle off once the thermostat demand is satisfied.

UNIT START-UP

IMPORTANT

If unit is equipped with a crankcase heater, it should be energized 24 hours before unit start-up to prevent compressor damage as a result of slugging.

- 1 - Rotate fan to check for binding.
- 2 - Inspect all factory- and field-installed wiring for loose connections.

- 3 - After evacuation is complete, open the liquid line and vapor line service valve stems to release the refrigerant charge (contained in outdoor unit) into the system.
- 4 - Replace the stem caps and tighten to the value listed in table 2.
- 5 - Check voltage supply at the disconnect switch. The voltage must be within the range listed on the unit's nameplate. If not, do not start the equipment until you have consulted with the power company and the voltage condition has been corrected.
- 6 - Connect manifold gauge set for testing and charging.
- 7 - Set the thermostat for a cooling demand. Turn on power to the indoor indoor unit and close the outdoor unit disconnect switch to start the unit.
- 8 - Recheck voltage while the unit is running. Power must be within range shown on the unit nameplate.
- 9 - Check system for sufficient refrigerant using the procedures outlined under *Checking Refrigerant Charge*.

OPERATING MANIFOLD GAUGE SET AND SERVICE VALVES

The liquid and vapor line service valves are used for removing refrigerant, flushing, leak testing, evacuating, checking charge and charging.

Each valve is equipped with a service port which has a factory-installed valve stem. Figures 14 and 15 provide information on how to access and operate both angle- and ball-type service valves.

Torque Requirements

When servicing or repairing heating, ventilating and air conditioning components, ensure the fasteners are appropriately tightened. Table 2 lists torque values for fasteners.

TABLE 1 – TORQUE REQUIREMENTS

| Parts | Recommended Torque | |
|---------------------|--------------------|-------|
| Service valve cap | 8 ft.-lb. | 11 NM |
| Sheet-metal screws | 16 in.-lb. | 2 NM |
| Machine screws #10 | 28 in.-lb. | 3 NM |
| Compressor bolts | 90 in.-lb. | 10 NM |
| Gauge port seal cap | 8 ft.-lb. | 11 NM |

IMPORTANT

To prevent stripping of the various caps used, the appropriately sized wrench should be used and fitted snugly over the cap before tightening.

Using Manifold Gauge Set

When checking the system charge, only use a manifold gauge set that features low loss anti-blow back fittings.

Manifold gauge set used with HFC-410A refrigerant systems must be capable of handling the higher system operating pressures. The gauges should be rated for use with pressures of 0 - 800 psig on the high side and a low side of 30" vacuum to 250 psig with dampened speed to 500 psi. Gauge hoses must be rated for use at up to 800 psig of pressure with a 4000 psig burst rating.

OPERATING BALL-TYPE SERVICE VALVE

- 1 - Remove stem cap with an appropriately sized wrench.
- 2 - Use an appropriately sized wrench to open. To open valve, rotate stem counterclockwise 90°. To close, rotate stem clockwise 90°.

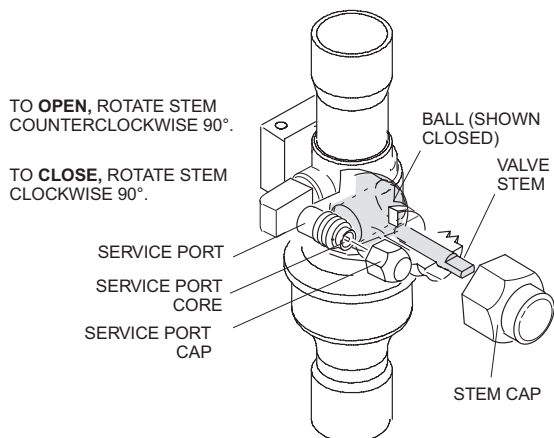
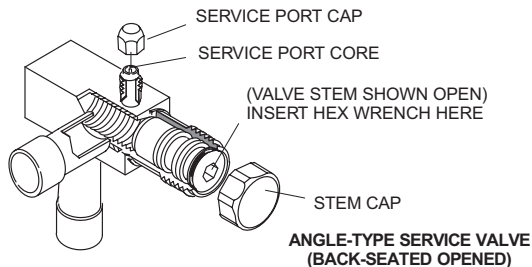

FIGURE 15

OPERATING ANGLE-TYPE SERVICE VALVE

- 1 - Remove stem cap with an appropriately sized wrench.
- 2 - Use a service wrench with a hex-head extension (3/16" for liquid line valve sizes and 5/16" for vapor line valve sizes) to back the stem out counterclockwise as far as it will go.



When service valve is **OPEN**, the service port is open to line set, indoor and outdoor unit.

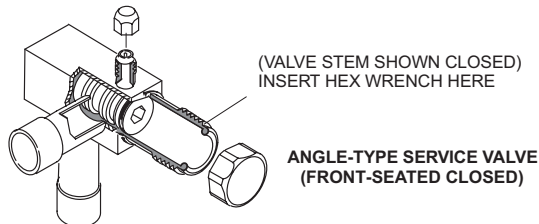

When service valve is **CLOSED**, the service port is open to the line set and indoor unit.

NOTE - A label with specific torque requirements may be affixed to the stem cap. If the label is present, use the specified torque.

FIGURE 16

ACCESS SERVICE PORT

A service port cap protects the service port core from contamination and serves as the primary leak seal.

- 1 - Remove service port cap with an appropriately sized wrench.
- 2 - Connect gauge set to service port.
- 3 - When testing is completed, replace service port cap and tighten as follows:
 - With torque wrench, finger tighten and torque cap per table 2.
 - Without torque wrench, finger tighten and use an appropriately sized wrench to turn an additional 1/6 turn clockwise.

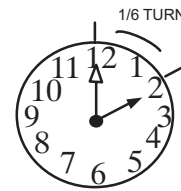

Reinstall Stem Cap

Stem cap protects the valve stem from damage and serves as the primary seal. Replace the stem cap and tighten as follows:

- With torque wrench, finger tighten and then torque cap per table 2.
- Without torque wrench, finger tighten and use an appropriately sized wrench to turn an additional 1/12 turn clockwise.



FIGURE 17

Checking Refrigerant Charge

The EL18XCV unit is factory-charged with enough HFC-410A refrigerant to accommodate a 15-foot length of refrigerant piping. For refrigerant piping greater than 15 feet, calculate the additional charge using the table below. Then add the additional charge specified for the specific indoor coil match-up listed on the unit charging sticker.

When charging the system with refrigerant or checking refrigerant, the "Charge Mode" (CHRG MODE) jumper provides the ability operate the unit at 100% capacity. See Charge Mode Jumper section on page 17 for details.

Charge should be checked and adjusted using the tables provided on the charging procedure sticker on the unit access panel. Detailed information is given in the EL18XCV Installation and Service Procedures manual, which is available on LennoxPros.com.

Refrigerant Charge per Line Set Length

| LIQUID LINE DIA. | OUNCES PER 5 FEET (G PER 1.5 M) ADJUST FROM 15 FEET (4.6 M) LINE SET* |
|------------------|---|
| 3/8" (9.5 MM) | 3 OUNCES PER 5' (85 G PER 1.5 M) |

*If line length is greater than 15 ft. (4.6 m), add this amount. If line length is less than 15 ft. (4.6 m), subtract this amount.

NOTE – Insulate liquid line when it is routed through areas where the surrounding ambient temperature could become higher than the temperature of the liquid line or when pressure drop is equal to or greater than 20 psig.

High Pressure Switch (S4)

This unit is equipped with a high pressure switch which is located on the liquid line. The SPST, normally closed pressure switch opens when liquid line pressure rises above the factory setting of 590 + 15 psig and automatically resets at 418 + 15 psig.

Homeowners Information

CAUTION

Before attempting to perform any service or maintenance, turn the electrical power to unit OFF at disconnect switch.

In order to ensure peak performance, your system must be properly maintained. Clogged filters and blocked air-flow prevent your unit from operating at its most efficient level. The system should be inspected and serviced before each cooling and heating season by a licensed professional HVAC service technician (or equivalent).

Homeowner Maintenance

The following maintenance may be performed by the homeowner.

- Contact a licensed professional HVAC technician to schedule inspection and maintenance appointments for your equipment before each heating and cooling season.
- Check the indoor unit filter each month and replace the filter, if necessary.
- Have your Lennox dealer show you where your indoor unit filter is located. It will be either at the indoor unit (installed internal or external to the cabinet) or behind a return air grille in the wall or ceiling. Check the filter monthly and clean or replace it as needed. Disposable filters should be replaced with a filter of the same type and size.
- Check the indoor unit drain line for obstructions monthly. The indoor coil is equipped with a drain pan to collect condensate formed as your system removes humidity from the inside air. Have your dealer show you the location of the drain line and how to check for obstructions. (This would also apply to an auxiliary drain, if installed.)
- Check the area around the outdoor unit monthly and remove any obstructions that may restrict airflow to the outdoor unit. This would include grass clippings, leaves, or papers that may have settled around the unit.
- Trim shrubbery away from the unit and periodically check for debris which collects around the unit.
- During the winter months, keep the snow level below the louvered panels.

NOTE - The filter and all access panels must be in place any time the unit is in operation. If you are unsure about the filter required for your system, call your Lennox dealer for assistance.

IMPORTANT

Sprinklers and soaker hoses should not be installed where they could cause prolonged exposure to the outdoor unit by treated water. Prolonged exposure of the unit to treated water (i.e., sprinkler systems, soakers, waste water, etc.) will corrode the surface of the steel and aluminum parts, diminish performance and affect longevity of the unit.

Thermostat Operation

See the thermostat homeowner manual for instructions on how to operate your thermostat.

Pre-Service Check

If your system fails to operate, check the following before calling for service:

- Verify room thermostat settings are correct.
- Verify that all electrical disconnect switches are ON.
- Check for any blown fuses or tripped circuit breakers.
- Verify unit access panels are in place.
- Verify air filter is clean.

If service is needed, locate and write down the unit model number and have it handy before calling.

Professional Maintenance

NOTICE !

Failure to follow instructions will cause damage to the unit.

This unit is equipped with an aluminum coil. Aluminum coils may be damaged by exposure to solutions with a pH below 5 or above 9. The aluminum coil should be cleaned using potable water at a moderate pressure (less than 50psi). If the coil cannot be cleaned using water alone, Lennox recommends use of a coil cleaner with a pH in the range of 5 to 9. The coil must be rinsed thoroughly after cleaning.

In coastal areas, the coil should be cleaned with potable water several times per year to avoid corrosive buildup (salt).

Your heating and air conditioning system should be inspected and maintained twice each year (before the start of the cooling and heating seasons) by a licensed professional HVAC technician. You can expect the technician to check the following items. **These checks may only be conducted by a licensed professional HVAC technician.**

Outdoor Unit

- 1 - Inspect component wiring for loose, worn or damaged connections. Also check for any rubbing or pinching of wires. Confirm proper voltage plus amperage of outdoor unit.
- 2 - Check the cleanliness of outdoor fan and blade condition (cracks) and clean or replace them, if necessary.
- 3 - Inspect base pan drains for debris and clean as necessary.
- 4 - Inspect the condition of refrigerant piping and confirm that pipes are not rubbing copper-to-copper. Also, check the condition of the insulation on the refrigerant lines. Repair, correct, or replace as necessary.
- 5 - Test capacitor. Replace as necessary.

- 6 - Inspect contactor contacts for pitting or burn marks. Replace as necessary.
- 7 - Check outdoor fan motor for worn bearings/bushings. Replace as necessary.
- 8 - Inspect and clean outdoor coils, if necessary and note any damage to coils or signs of leakage.

Indoor Unit (Air Handler or Furnace)

- 1 - Inspect component wiring for loose, worn or damaged connections. Confirm proper voltage plus amperage of indoor unit.
- 2 - Inspect and clean or replace air filters in indoor unit.
- 3 - Check the cleanliness of indoor blower and clean blower, if necessary.
- 4 - Inspect the indoor coil drain pans and condensate drains for rust, debris, obstructions, leaks or cracks. Pour water in pans to confirm proper drainage from the pan through to the outlet of the pipe. Clean or replace as necessary.
- 5 - Inspect and clean indoor coil, if necessary.

- 6 - Inspect the condition of the refrigerant lines and confirm that pipes are not rubbing copper-to-copper. Also, ensure that refrigerant pipes are not being affected by indoor air contamination. Check condition of insulation on the refrigerant lines. Repair, correct, or replace as necessary.
- 7 - Inspect the duct system for leaks or other problems. Repair or replace as necessary.
- 8 - Check for bearing/bushing wear on indoor blower motor. Replace as necessary.
- 9 - If your heat pump is matched with a gas- or oil-fired furnace for auxiliary heating, indoor unit service will also include inspection and cleaning of the burners, and a full inspection of the gas valve, heat exchanger and flue (exhaust) system.

General System Test with System Operating

- 1 - Your technician should perform a general system test. He will turn on the air conditioner to check operating functions such as the startup and shutoff operation. He will also check for unusual noises or odors, and measure indoor/outdoor temperatures and system pressures as needed. He will check the refrigerant charge per the charging sticker information on the outdoor unit.
- 2 - Verify that system total static pressure and airflow settings are within specific operating parameters.
- 3 - Verify correct temperature drop across indoor coil.

EL18XCV Start-Up and Performance Checklist

Customer _____ Address _____

Indoor Unit Model _____ Serial _____

Outdoor Unit Model _____ Serial _____

Notes: _____

START UP CHECKS

Refrigerant Type: _____

Rated Load Amps: _____ Actual Amps ___ Rated Volts _____ Actual Volts _____

Condenser Fan Full Load Amps _____ Actual Amps: ___

COOLING MODE

Suction Pressure: _____ Liquid Pressure: _____

Supply Air Temperature: _____ Ambient Temperature: _____ Return Air Temperature: _____

System Refrigerant Charge (Refer to manufacturer's information on unit or installation instructions for required subcooling and approach temperatures.)

| | |
|--|------------------------|
| Subcooling: | A — B = SUBCOOLING |
| Saturated Condensing Temperature (A) <i>minus</i> Liquid Line Temperature (B) | |
| Approach: | A — B = APPROACH |
| Liquid Line Temperature (A) <i>minus</i> Outdoor Air Temperature (B) | |
| Indoor Coil Temperature Drop (18 to 22°F) | A — B = COIL TEMP DROP |
| Return Air Temperature (A) <i>minus</i> Supply Air Temperature (B) | |