



NTI Boilers Inc.
Tel: (506) 657-6000
Toll Free: 1-800-688-2575
Fax: 1-506-432-1135
Web: www.ntiboilers.com
Email:
info@ntiboilers.com

84946 & 84947

ProtoNode Startup Guide

RER and LER Gateway Interface for Building Management Systems

CAUTION

ProtoNode - The RER and LER models are used for interfacing applicable NY Thermal Boilers to the appropriate automated Building Management Systems. Failure to follow instructions in the Startup Guide may result in equipment damage, property damage or personal injury.

Applicable NTI Boiler Models:

- Lx150-800, Lx200WH-800WH, Tft60-399, FTG 600-2400

84946 - ProtoNode RER

84946 ProtoNode RER Kit Includes:

- ProtoNode RER ModBus-BACnet-N2 Gateway (FPC-N34-0855)
- ProtoNode Startup Guide

RER Building Automation Systems:

- BACnet MS/TP, BACnet/IP, Modbus/TCP, Metasys N2

84947 - ProtoNode LER

84947 ProtoNode LER Kit Includes:

- ProtoNode LER Modbus-LonWorks Gateway (FPC-N35-0856)
- ProtoNode Startup Guide

LER Building Automation Systems

- LonWorks



APPLICABILITY & EFFECTIVITY

Explains ProtoNode FPC-N34 and FPC-N35 hardware and how to install it.

The instructions are effective for the above as of December 2015.



A Quick Start Guide

1. Record the information about the unit. (**Section 2.1**)
2. Set the device's Modbus RTU serial settings (i.e. baud rate, parity, stop bits) and Modbus Node-ID for each of the devices that will be connected to ProtoNode FPC-N34 or FPC-N35. (**Section 2.3**)
3. ProtoNode FPC-N34 units: Select the Field Protocol (BACnet MS/TP, BACnet/IP, Modbus TCP/IP or Metasys N2) on the S Bank Dip Switches. (**Section 2.4.1**)
4. Enable the ProtoNode "Auto Discovery" mode on Dip Switch Bank S. (**Section 2.4.2**)
5. BACnet MS/TP (FPC-N34): Set the MAC Address on DIP Switch Bank A. (**Section 2.5.1**)
6. BACnet MS/TP or BACnet/IP (FPC-N34): Set the BACnet Device Instance. (**Section 2.5.2**)
7. Metasys N2 or Modbus TCP/IP (FPC-N34): Set the Node-ID. (**Section 2.5.3**)
8. BACnet MS/TP (FPC-N34): Set the BAUD rate of the BACnet MS/TP Field Protocol on DIP Switch Bank B. (**Section 2.5.4**)
9. **Connect ProtoNode FPC-N34's** 3 pin RS-485 port to the Field Protocol cabling, **or connect ProtoNode FPC-N35's** 2 pin LonWorks port to the Field Protocol cabling. (**Section 3.2**)
10. Connect ProtoNode's 6 pin RS-485 connector to the Modbus RS-485 network that is connected to each of the devices. (**Section 3.3**)
11. Connect Power to ProtoNode's 6 pin connector. (**Section 3.5**)
12. When power is applied it will take about 3 minutes for all the devices to be discovered, and the configuration file to be built. Once Auto-Discovery is complete turn OFF the S3 DIP Switch to save the configuration settings. (**Section 3.5.1**)
13. BACnet/IP or Modbus TCP/IP (FPC-N34): Use the ProtoNode's embedded tool which is accessed with a browser, referred to in this manual as the Web Configurator, to change the IP Address. No changes to the configuration file are necessary. (**Section 4**)
14. LonWorks (FPC-N35): The ProtoNode must be commissioned on the LonWorks Network. This needs to be done by the LonWorks administrator using a LonWorks Commissioning tool. (**Section 7**)

Certifications

▪ BTL MARK – BACNET TESTING LABORATORY



BACnet is a registered trademark of ASHRAE. ASHRAE does not endorse, approve or test products for compliance with ASHRAE standards. Compliance of listed products to requirements of ASHRAE Standard 135 is the responsibility of the BACnet International. BTL is a registered trademark of the BACnet International.

The BTL Mark on ProtoNode is a symbol that indicates that a product has passed a series of rigorous tests conducted by an independent laboratory which verifies that the product correctly implements the BACnet features claimed in the listing. The mark is a symbol of a high-quality BACnet product.

Go to <http://www.BACnetInternational.net/btl/> for more information about the BACnet Testing Laboratory. Click here for [BACnet PIC Statement](#).

▪ LONMARK CERTIFICATION



LonMark International is the recognized authority for certification, education, and promotion of interoperability standards for the benefit of manufacturers, integrators and end users. LonMark International has developed extensive product certification standards and tests to provide the integrator and user with confidence that products from multiple manufacturers utilizing LonMark devices work together. Sierra Monitor has more LonMark Certified gateways than any other gateway manufacturer, including the ProtoCessor, ProtoCarrier and ProtoNode for OEM applications and the full featured, configurable gateways.



TABLE OF CONTENTS

- 1 Introduction 6**
 - 1.1 ProtoNode Gateway 6
- 2 BACnet/LonWorks Setup for ProtoCessor ProtoNode FPC-N34/FPC-N35 7**
 - 2.1 Record Identification Data 7
 - 2.2 Point Count Capacity and Registers per Device 7
 - 2.3 Configuring Device Communications 8
 - 2.3.1 Set Modbus COM setting on all of the Devices connected to the ProtoNode 8
 - 2.3.2 Set Modbus RTU Node-ID for each of the Devices attached to the ProtoNode 8
 - 2.4 Selecting the Desired Field Protocol and Enabling Auto-Discovery 9
 - 2.4.1 Selecting Desired Field Protocol 9
 - 2.4.2 Enabling Auto-Discovery 10
 - 2.5 BMS Network Settings: MAC Address, Device Instance and Baud Rate 11
 - 2.5.1 BACnet MS/TP (FPC-N34): Setting the MAC Address for BMS Network 11
 - 2.5.2 BACnet MS/TP and BACnet/IP (FPC-N34): Setting the Device Instance 12
 - 2.5.3 Metasys N2 or Modbus TCP/IP (FPC-N34): Setting the Node-ID 12
 - 2.5.4 BACnet MS/TP (FPC-N34): Setting the Baud Rate for BMS Network 13
- 3 Interfacing ProtoNode to Devices 14**
 - 3.1 ProtoNode FPC-N34 and FPC-N35 Showing Connection Ports 14
 - 3.2 Device Connections to ProtoNode 15
 - 3.2.1 Biasing the Modbus RS-485 Device Network 16
 - 3.2.2 End of Line Termination Switch for the Modbus RS-485 Device Network 17
 - 3.3 BACnet MS/TP or Metasys N2 (FPC-N34): Wiring Field Port to RS-485 BMS Network 18
 - 3.4 LonWorks (FPC-N35): Wiring Field Port to LonWorks Network 18
 - 3.5 Power-Up ProtoNode 19
 - 3.5.1 Auto-Discovery: After Completion – Turn Off to Save Configuration 19
- 4 BACnet/IP or Modbus TCP/IP: Change the Protonode IP Address 21**
 - 4.1 Connect the PC to ProtoNode via the Ethernet Port 21
 - 4.2 BACnet/IP and Modbus TCP/IP: Setting IP Address for Field Network 22
- 5 BACnet MS/TP and BACnet/IP: Setting Node_Offset to Assign Specific Device Instances 24**
- 6 How to Start the Installation Over: Clearing Profiles 25**
- 7 LonWorks (FPC-N35): Commissioning ProtoNode on a Lonworks Network 26**
 - 7.1 Commissioning ProtoNode FPC-N35 on a LonWorks Network 26
 - 7.1.1 Instructions to Download XIF File from ProtoNode FPC-N35 Using Browser 26
- 8 CAS BACnet Explorer for Validating ProtoNode in the Field 28**
 - 8.1 Downloading the CAS Explorer and Requesting an Activation Key 28
 - 8.2 CAS BACnet Setup 29
 - 8.2.1 CAS BACnet MS/TP Setup 29
 - 8.2.2 CAS BACnet BACnet/IP Setup 29
- 9 NTI Field Wiring Diagrams 30**
 - 9.1 Tft-Lx ProtoNode RS485 Wiring, Single S7999C (White Display) 30
 - 9.2 Tft-Lx ProtoNode RS485 Wiring, Multiple S7999C (White Display) 31
 - 9.3 Tft-Lx ProtoNode RS485 Wiring, S7999D (Black Display) 32
 - 9.4 Lx Commercial ProtoNode RS485 Wiring, Single S7999C (White Display) 33
 - 9.5 Lx Commercial ProtoNode RER RS485 Wiring, S7999D (Black Display) 34
 - 9.6 FTG ProtoNode RER RS485 Wiring, S7999D (Black Display) 35
- Appendix A. Troubleshooting 36**
 - Appendix A.1. Lost or Incorrect IP Address 36
 - Appendix A.2. Viewing Diagnostic information 37
 - Appendix A.3. Check Wiring and Settings 37
 - Appendix A.4. Take Diagnostic Capture With the FieldServer Utilities 38
 - Appendix A.5. BACnet: Setting Network_Number for more than one ProtoNode on Subnet 41
 - Appendix A.6. LED Diagnostics for Communications Between ProtoNode and Devices 42



Appendix A.7. Passwords 42

Appendix B. Vendor Information – NY Thermal..... 43

Appendix B.1. Sola Modbus RTU Mappings to BACnet, Metasys N2 and LonWorks..... 43

Appendix C. “A” Bank DIP Switch Settings 49

Appendix C.1. “A” Bank DIP Switch Settings 49

Appendix D. Reference..... 52

Appendix D.1. Specifications..... 52

Appendix D.1.1. Compliance with UL Regulations 52

Appendix E. Limited 2 Year Warranty 53

LIST OF FIGURES

Figure 1: ProtoCessor Part Numbers..... 7

Figure 2: Supported Point Count Capacity 7

Figure 3: Modbus Registers per Device 7

Figure 4: Modbus RTU COM Settings 8

Figure 5: S Bank DIP Switches 9

Figure 6: S3 DIP Switch setting for Auto Discovering Devices..... 10

Figure 7: MAC address DIP switches 11

Figure 8: BMS Baud Rate DIP Switches..... 13

Figure 9: BMS Baud Rate 13

Figure 10: ProtoNode BACnet FPC-N34 (upper) and ProtoNode FPC-N35 (lower) 14

Figure 11: Power and RS-485 Connections 15

Figure 12: Modbus RS-485 Biasing Switch on the ProtoNode N34 (left) and ProtoNode N35 (right)..... 16

Figure 13: Modbus RS-485 End-Of-Line Termination Switch on the ProtoNode N34 (left) and 17

Figure 14: Connection from ProtoNode to RS-485 Field Network..... 18

Figure 15: RS-485 BMS Network EOL Switch..... 18

Figure 16: LonWorks Terminal..... 18

Figure 17: Required current draw for the ProtoNode..... 19

Figure 18: Power Connections..... 19

Figure 19: S3 DIP Switch setting for Auto Discovering Devices..... 20

Figure 20: Web Configurator Screen 22

Figure 21: Changing IP Address via Web GUI 23

Figure 22: Web Configurator screen with Active Profiles 24

Figure 23: LonWorks Service Pin Location..... 26

Figure 24: Sample of Fserver.XIF File Generated 27

Figure 25: Downloading the CAS Explorer 28

Figure 26: Requesting CAS Activation Key 28

Figure 27: Tft-Lx ProtoNode RS485 Wiring, Single S7999C (White Display) 30

Figure 28: Tft-Lx ProtoNode RS485 Wiring, Multiple S7999C (White Display) 31

Figure 29: Tft-Lx ProtoNode RS485 Wiring, S7999D (Black Display)..... 32

Figure 30: Lx Commercial ProtoNode RS485 Wiring, Single S6999C (White Display)..... 33

Figure 31: Lx Commercial ProtoNode RER RS485 Wiring , S7999D (Black Display) 34

Figure 32: FTG ProtoNode RER RS485 Wiring, S7999D (Black Display) 35

Figure 33: Ethernet Port Location 36

Figure 34: Error messages screen..... 37

Figure 35: Ethernet Port Location 38

Figure 36: Web Configurator – Setting Network Number for BACnet..... 41

Figure 37: Diagnostic LEDs 42

Figure 38: Specifications..... 52

1 INTRODUCTION

1.1 ProtoNode Gateway

ProtoNode is an external, high performance **Building Automation multi-protocol gateway** that is preconfigured to Auto-Discover any of NY Thermal’s products (hereafter called “device”) connected to the ProtoNode and automatically configures them for BACnet^{®1} MS/TP, BACnet/IP, Metasys^{®2} N2 by JCI, Modbus TCP/IP or LonWorks^{®3}.

It is not necessary to download any configuration files to support the required applications. The ProtoNode is pre-loaded with tested Profiles/Configurations for the supported devices.

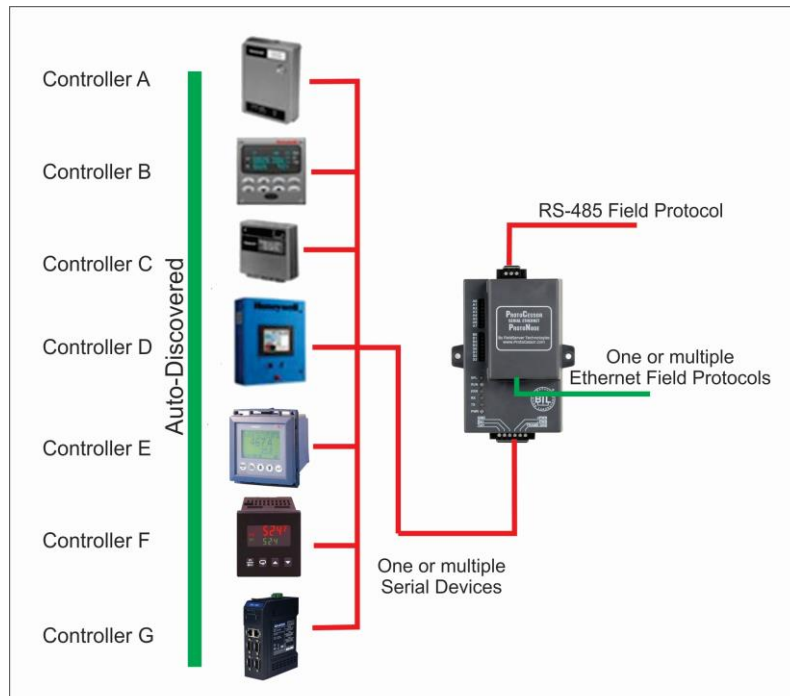

¹ BACnet is a registered trademark of ASHRAE
² Metasys is a registered trademark of Johnson Controls Inc.
³ LonWorks is a registered trademark of Echelon Corporation

2 BACNET/LONWORKS SETUP FOR PROTOCESSOR PROTONODE FPC-N34/FPC-N35

2.1 Record Identification Data

Each ProtoNode has a unique part number located on the side or the back of the unit. This number should be recorded, as it may be required for technical support. The numbers are as follows:

| Model | Part Number |
|---|--------------|
| ProtoNode N34 | FPC-N34-0855 |
| ProtoNode N35 | FPC-N35-0856 |
| Figure 1: ProtoCessor Part Numbers | |

- FPC-N34 units have the following 3 ports: RS-485 + Ethernet + RS-485
- FPC-N35 units have the following 3 ports: LonWorks + Ethernet + RS-485

2.2 Point Count Capacity and Registers per Device

The total number of Modbus Registers presented by all of the devices attached to the ProtoNode cannot exceed:

| Part number | Total Registers |
|---|-----------------|
| FPC-N34-0855 | 1,500 |
| FPC-N35-0856 | 1,500 |
| Figure 2: Supported Point Count Capacity | |

| Devices | Registers Per Device |
|--|----------------------|
| Sola | 163 |
| Figure 3: Modbus Registers per Device | |

2.3 Configuring Device Communications

2.3.1 Set Modbus COM setting on all of the Devices connected to the ProtoNode

- All of the serial devices connected to ProtoNode **MUST have the same Baud Rate, Data Bits, Stop Bits, and Parity settings.**
- **Figure 4** specifies the device serial port settings required to communicate with the ProtoNode.

| Serial Port Setting | Device |
|--|------------|
| Protocol | Modbus RTU |
| Baud Rate | 38400 |
| Parity | None |
| Data Bits | 8 |
| Stop Bits | 1 |
| Figure 4: Modbus RTU COM Settings | |

2.3.2 Set Modbus RTU Node-ID for each of the Devices attached to the ProtoNode

- Set Modbus Node-ID for each of the devices attached to ProtoNode. The Modbus Node-ID's need to be uniquely assigned between 1 and 255.
 - **The Modbus Node-ID that is assigned for each device needs to be documented**
 - The Modbus Node-ID's assigned are used for designating the Device Instance for BACnet/IP and BACnet MS/TP (**Section 2.5.2**)
- The Metasys N2 and Modbus TCP/IP Node-ID will be set to same value as the Node-ID of the Modbus RTU device.

2.4 Selecting the Desired Field Protocol and Enabling Auto-Discovery

2.4.1 Selecting Desired Field Protocol

- ProtoNode FPC-N34 units use the “S” bank of DIP switches (S0 – S2) to select the Field Protocol.
 - See the table in **Figure 5** for the switch settings to select BACnet MS/TP, BACnet/IP, Modbus TCP/IP, or Metasys N2
 - The OFF position is when the DIP switches are set closest to the outside of the box
- ProtoNode FPC-N35 units do not use the “S” bank DIP switches (S0 – S2) to select a Field Protocol.
 - On ProtoNode FPC-N35 units, these switches are disabled; the Field Protocol is always LonWorks
 - On ProtoNode FPC-N35 units, there is no need to select profiles for Celsius or Fahrenheit

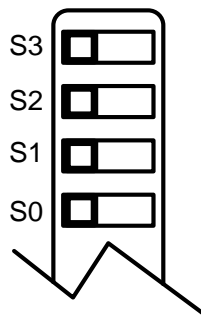

S0 – S3 DIP Switches



S Bank DIP Switch Location

| ProtoNode FPC-N34 | S Bank DIP Switches | | |
|---|---------------------|-----|-----|
| Profile | S0 | S1 | S2 |
| BACnet/IP Deg F | Off | Off | Off |
| BACnet MS/TP Deg F | On | Off | Off |
| Metasys N2 Deg F | Off | On | Off |
| Modbus TCP/IP | On | On | Off |
| BACnet/IP Deg C | Off | Off | On |
| BACnet MS/TP Deg C | On | Off | On |
| Metasys N2 Deg C | Off | On | On |
| BACnet MS/TP, BACnet/IP, Modbus TCP/IP, and Metasys N2 Settings for ProtoNode FPC-N34 (BACnet) | | | |
| Figure 5: S Bank DIP Switches | | | |

2.4.2 Enabling Auto-Discovery

NOTE: If Modbus TCP/IP was selected in Section 2.4.1 for the Field/BMS protocol, skip this section. Auto-Discovery is NOT used for Modbus TCP/IP.

- The S3 DIP switch is used to both enable Auto-Discovery of known devices attached to the ProtoNode, and to save the recently discovered configuration.
 - See the table in [Figure 6](#) for the switch setting to enable Auto-Discovery
 - If the ProtoNode is being installed for the first time, set S3 to the ON position to enable Auto-Discovery
 - The ON position is when the DIP switches are set closest to the inside of the box

| S3 DIP Switch Auto-Discovery Mode | S3 |
|--|-----|
| Auto-Discovery ON – Build New Configuration | On |
| Auto-Discover OFF – Save Current Configuration | Off |

[Figure 6: S3 DIP Switch setting for Auto Discovering Devices](#)

2.5 BMS Network Settings: MAC Address, Device Instance and Baud Rate

2.5.1 BACnet MS/TP (FPC-N34): Setting the MAC Address for BMS Network

- Only 1 MAC address is set for ProtoNode regardless of how many devices are connected to ProtoNode.
- Set the BACnet MS/TP MAC addresses of the ProtoNode to a value between 1 to 127 (MAC Master Addresses); this is so that the BMS Front End can find the ProtoNode via BACnet auto discovery.

NOTE: Never set a BACnet MS/TP MAC Address from 128 to 255. Addresses from 128 to 255 are Slave Addresses and can not be discovered by BMS Front Ends that support auto discovery of BACnet MS/TP devices.

- Set “A” bank DIP switches A0 – A7 to assign a MAC Address to the ProtoNode for BACnet MS/TP.
- Please refer to [Appendix C.1](#) for the complete range of MAC Addresses and DIP switch settings.

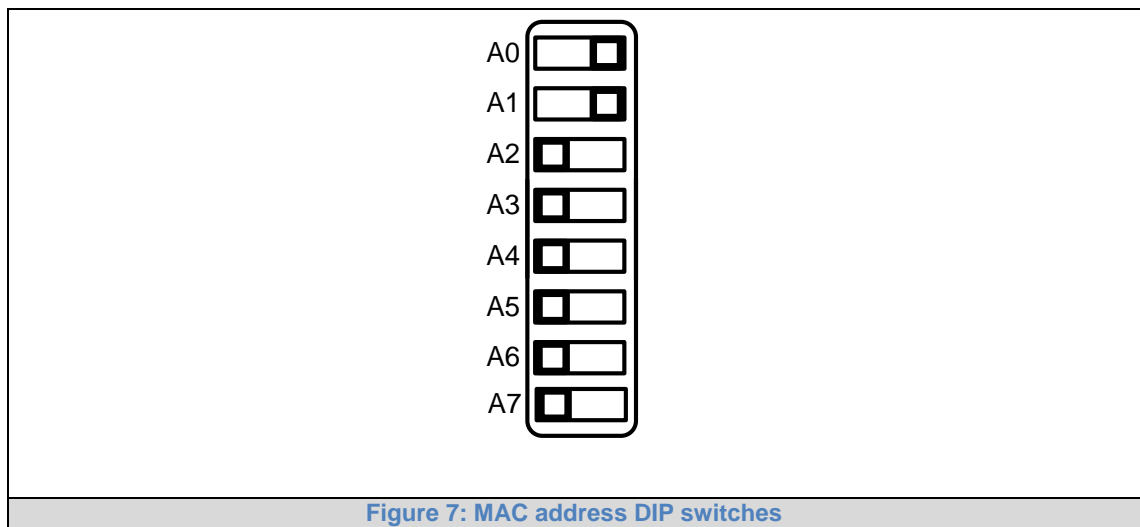

Figure 7: MAC address DIP switches

NOTE: When setting DIP Switches, please ensure that power to the board is OFF.

2.5.2 BACnet MS/TP and BACnet/IP (FPC-N34): Setting the Device Instance

- The BACnet Device Instances will be calculated by adding the Node_Offset (default value is 50,000) to the device's Modbus Node ID (that was assigned in **Section 2.3.2**).
- The BACnet Device Instance can range from 1 to 4,194,303.
- **To assign specific Device Instance values, change the Node_Offset value. (Section 2.3.2)**

For example:

- Node_Offset value (default) = 50,000
- Device 1 has a Modbus Node-ID of 1
- Device 2 has a Modbus Node-ID of 22
- Device 3 has a Modbus Node-ID of 33
- **Given that: Device Instance = Node_Offset + Modbus Node_ID**
- Device Instance, Device 1 = 50,000 + 1 = 50,001
- Device Instance, Device 2 = 50,000 + 22 = 50,022
- Device Instance, Device 3 = 50,000 + 33 = 50,033

2.5.2.1 BACnet MS/TP or BACnet/IP: Assigning Specific Device Instances

- With the default Node_Offset value of 50,000 the Device Instances values generated will be within the range of 50,001 to 50,127.
- The values allowed for a BACnet Device Instance can range from 1 to 4,194,303.
- To assign a specific Device Instance (or range), change the Node_Offset value.
- **Methods for changing the Node_Offset value are provided in Section 5.**
 - This step cannot be performed until after the unit is connected and powered

2.5.3 Metasys N2 or Modbus TCP/IP (FPC-N34): Setting the Node-ID

- The Modbus RTU Node-ID's assigned to the devices attached to the ProtoNode in **Section 2.3.2** will be the Metasys N2 or Modbus TCP/IP Node-ID's to the field protocols.
- Metasys N2 and Modbus TCP/IP Node-ID Addressing: Metasys N2 and Modbus TCP/IP Node-ID's range from 1-255.

2.5.4 BACnet MS/TP (FPC-N34): Setting the Baud Rate for BMS Network

- “B” bank DIP switches B0 – B3 can be used to set the Field baud rate of the ProtoNode to match the baud rate required by the Building Management System for BACnet MS/TP.
- The baud rate on ProtoNode for Metasys N2 is set for 9600. “B” bank DIP switches B0 – B3 are disabled for Metasys N2 on ProtoNode FPC-N34.
- “B” bank DIP switches B0 – B3 are disabled on ProtoNode FPC-N35 (FPC-N35 LonWorks).

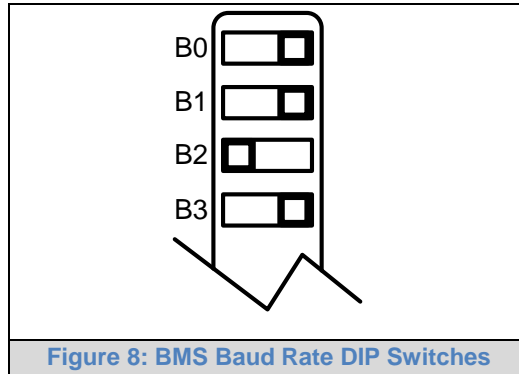

Figure 8: BMS Baud Rate DIP Switches

2.5.4.1 Baud Rate DIP Switch Selection

| Baud | B0 | B1 | B2 | B3 |
|---------------|-----------|-----------|------------|-----------|
| 9600 | On | On | On | Off |
| 19200 | Off | Off | Off | On |
| 38400* | On | On | Off | On |
| 57600 | Off | Off | On | On |
| 76800 | On | Off | On | On |

Figure 9: BMS Baud Rate

* Factory default setting = 38,400

3 INTERFACING PROTONODE TO DEVICES

3.1 ProtoNode FPC-N34 and FPC-N35 Showing Connection Ports

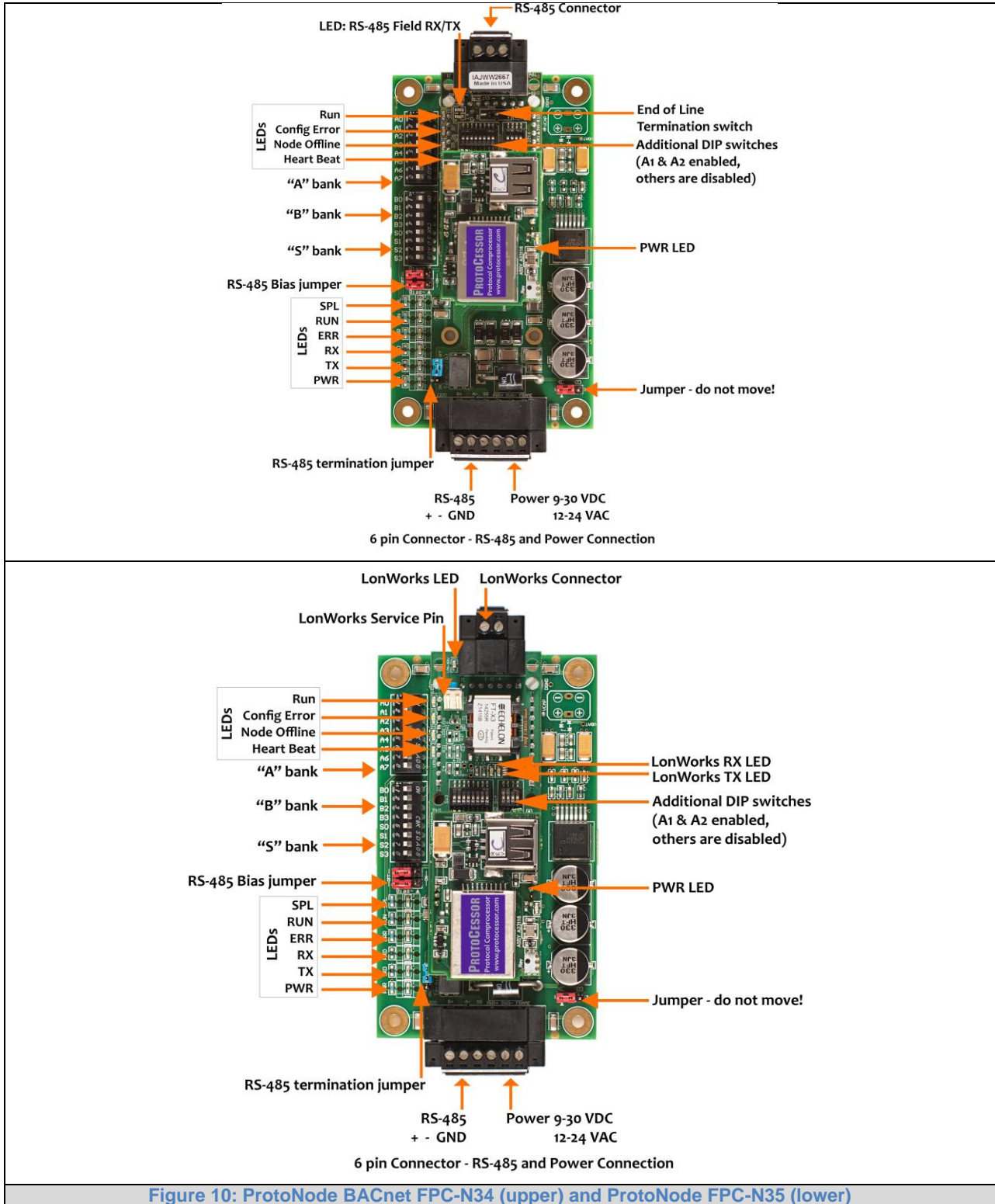
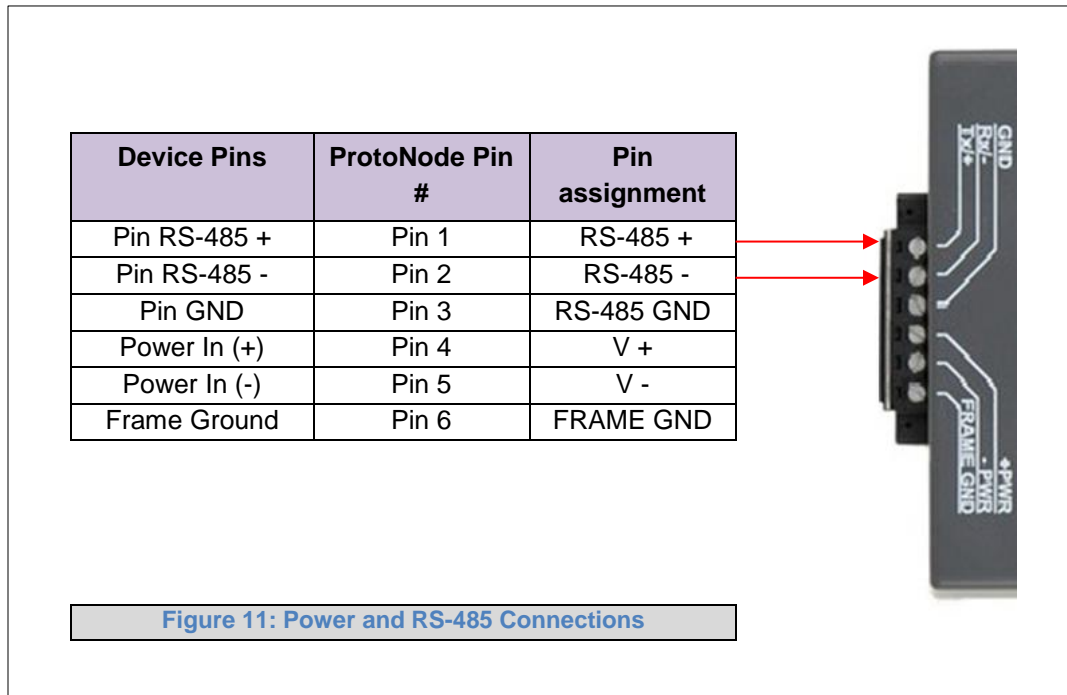

Figure 10: ProtoNode BACnet FPC-N34 (upper) and ProtoNode FPC-N35 (lower)

3.2 Device Connections to ProtoNode

ProtoNode 6 Pin Phoenix connector for RS-485 Devices

- The 6 pin Phoenix connector is the same for ProtoNode FPC-N34 (BACnet) and FPC-N35 (LonWorks).
- Pins 1 through 3 are for Modbus RS-485 devices.
 - The RS-485 GND (Pin 3) is not typically connected
- Pins 4 through 6 are for power. **Do not connect power until Section 3.5.**



3.2.1 Biasing the Modbus RS-485 Device Network

- An RS-485 network with more than one device needs to have biasing to ensure proper communication. The biasing only needs to be done on one device.
- The ProtoNode has 510 Ohm resistors that can be used to set the biasing. The ProtoNode's default positions from the factory for the Biasing jumpers are OFF.
- The OFF position is when the 2 RED biasing jumpers straddle the 4 pins closest to the outside of the board of the ProtoNode. ([Error! Reference source not found.](#))
- **Only turn biasing ON:**
 - **IF the BMS cannot see more than one device connected to the ProtoNode**
 - **AND all the settings (Modbus COM settings, wiring, and DIP switches) have been checked**
- To turn biasing ON, move the 2 RED biasing jumpers to straddle the 4 pins closest to the inside of the board of the ProtoNode.

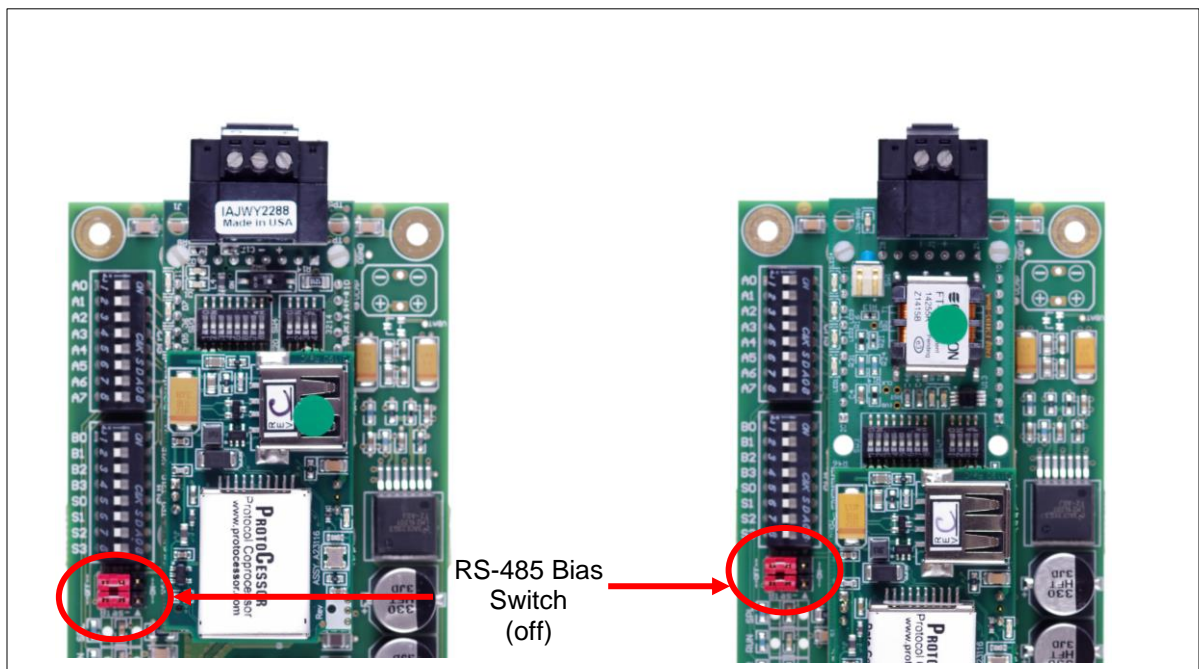

Figure 12: Modbus RS-485 Biasing Switch on the ProtoNode N34 (left) and ProtoNode N35 (right)

3.2.2 End of Line Termination Switch for the Modbus RS-485 Device Network

- On long RS-485 cabling runs, the RS-485 trunk must be properly terminated at each end.
- The ProtoNode has an End Of Line (EOL) blue jumper. The default setting for this Blue EOL switch is OFF with the jumper straddling the pins closest to the inside of the board of the ProtoNode.
 - On short cabling runs the EOL switch does not need to be turned ON
- **If the ProtoNode is placed at one of the ends of the trunk, set the blue EOL jumper to the ON position straddling the pins closest to the outside of the board of the ProtoNode.**
- **Always leave the single Red Jumper in the A position (default factory setting).**

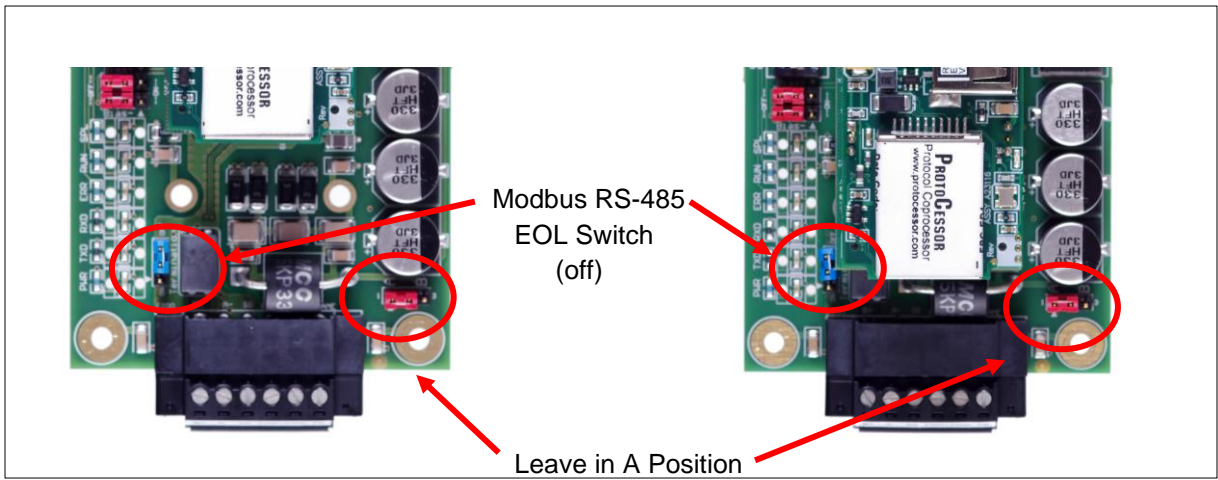

Figure 13: Modbus RS-485 End-Of-Line Termination Switch on the ProtoNode N34 (left) and ProtoNode N35 (right)

3.3 BACnet MS/TP or Metasys N2 (FPC-N34): Wiring Field Port to RS-485 BMS Network

- Connect the BACnet MS/TP or Metasys N2 RS-485 network wires to the 3-pin RS-485 connector on ProtoNode FPC-N34. (Figure 14)
 - The RS-485 GND (Pin 3) is not typically connected
- See **Section 5** for information on connecting to BACnet/IP network.
- If the ProtoNode is the last device on the BACnet MS/TP or Metasys N2 trunk, then the End-Of-Line Termination Switch needs to be enabled. (Figure 15)
 - The default setting from the factory is OFF (switch position = right side)
 - To enable the EOL Termination, turn the EOL switch ON (switch position = left side)

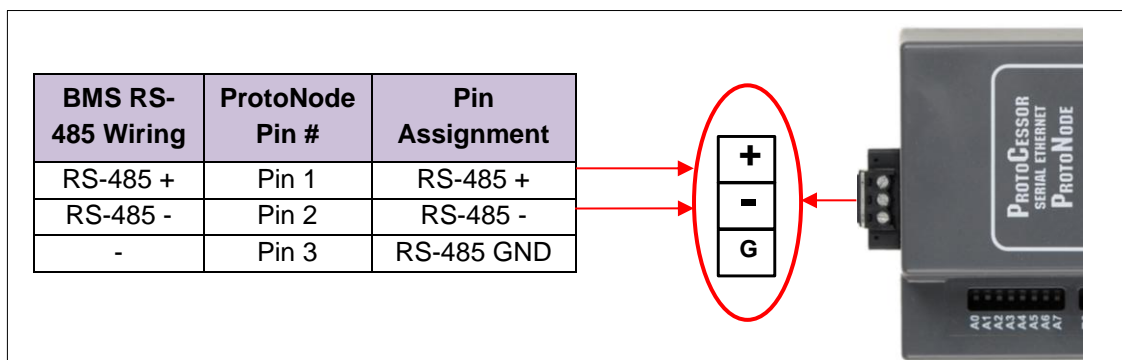

Figure 14: Connection from ProtoNode to RS-485 Field Network

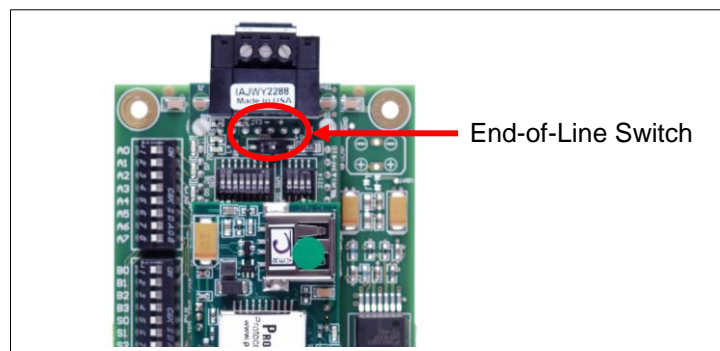

Figure 15: RS-485 BMS Network EOL Switch

3.4 LonWorks (FPC-N35): Wiring Field Port to LonWorks Network

- Connect ProtoNode to the field network with the LonWorks terminal using a twisted pair non-shielded cable. LonWorks has no polarity.



Figure 16: LonWorks Terminal

3.5 Power-Up ProtoNode

Apply power to ProtoNode as show below in **Figure 18**. Ensure that the power supply used complies with the specifications provided in **Appendix D.1**.

- ProtoNode accepts either 9-30VDC or 12-24 VAC on pins 4 and 5.
- **Frame GND should be connected.**

| Power Requirement for ProtoNode External Gateway | | | |
|--|-------------------|-----------|-------|
| ProtoNode Family | Current Draw Type | | |
| | 12VDC/VAC | 24VDC/VAC | 30VDC |
| FPC – N34 (Typical) | 170mA | 100mA | 80mA |
| FPC – N34 (Maximum) | 240mA | 140mA | 100mA |
| FPC – N35 (Typical) | 210mA | 130mA | 90mA |
| FPC – N35 (Maximum) | 250mA | 170mA | 110mA |

NOTE: These values are 'nominal' and a safety margin should be added to the power supply of the host system. A safety margin of 25% is recommended.

Figure 17: Required current draw for the ProtoNode

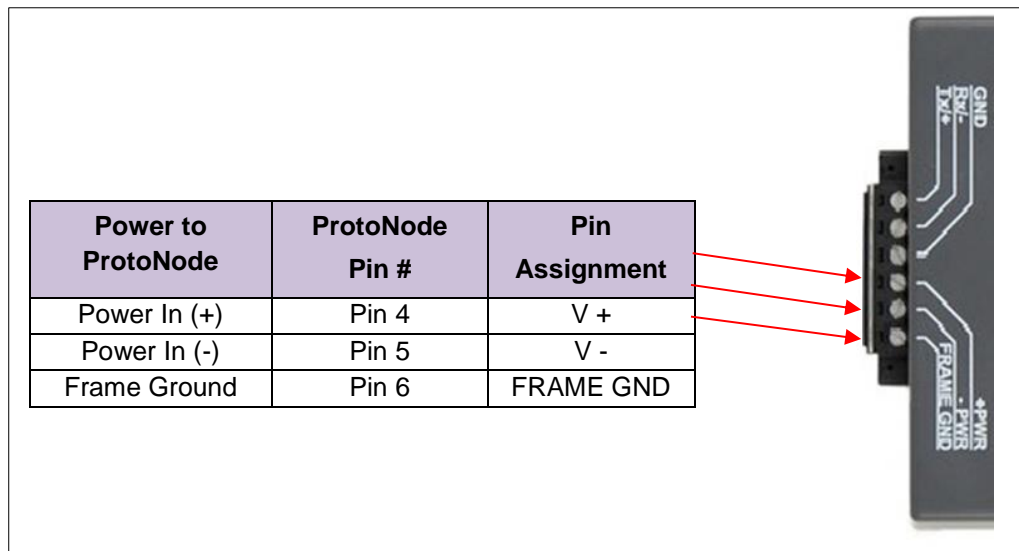

Figure 18: Power Connections

3.5.1 Auto-Discovery: After Completion – Turn Off to Save Configuration

NOTE: If Modbus TCP/IP was selected in Section 2.4.1 for the Field/BMS protocol, skip this section. Auto-Discovery is NOT used for Modbus TCP/IP.

The S3 DIP Switch for Enabling Auto-Discovery should have been set in Section 2.4.2 before applying power to the ProtoNode. **Do not** Enable Auto-Discovery when the unit is powered.





- When power is applied to a ProtoNode that is set to Enable Auto-Discovery, it will take 3 minutes to complete the discovery of all of the RS-485 devices attached to the ProtoNode.
- **Once the ProtoNode has discovered all of the RS-485 devices, set the S3 DIP switch to the OFF position to save the current configuration.**

| ProtoNode FPC-N34 and FPC-N35 | |
|--|-----|
| S3 DIP Switch Auto-Discovery Mode | S3 |
| Auto-Discovery ON – Build New Configuration | On |
| Auto-Discover OFF – Save Current Configuration | Off |
| Figure 19: S3 DIP Switch setting for Auto Discovering Devices | |

4 BACNET/IP OR MODBUS TCP/IP: CHANGE THE PROTONODE IP ADDRESS

4.1 Connect the PC to ProtoNode via the Ethernet Port

- Connect a CAT5 Ethernet cable (Straight through or Cross-Over) between the PC and ProtoNode.
- The Default IP Address of ProtoNode is **192.168.1.24**, Subnet Mask is **255.255.255.0**. If the PC and ProtoNode are on different IP Networks, assign a static IP Address to the PC on the 192.168.1.xxx network.

- Go to  >  Control Panel >  Network Connections
- Right-click on Local Area Connection > Properties
- Highlight  Internet Protocol (TCP/IP) > 
- Select: Use the following IP Address

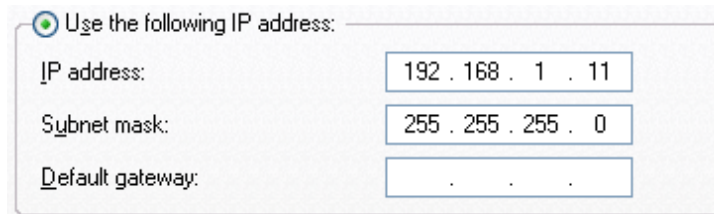

| | |
|-------------------------------|---------------------|
| Use the following IP address: | |
| IP address: | 192 . 168 . 1 . 11 |
| Subnet mask: | 255 . 255 . 255 . 0 |
| Default gateway: | . . . |

- Click  twice

4.2 BACnet/IP and Modbus TCP/IP: Setting IP Address for Field Network

- After setting a local PC to be on the same subnet as the ProtoNode (**Section 4.1**), open a web browser on the PC and enter the IP Address of the ProtoNode; the default address is 192.168.1.24.
- The Web Configurator will be displayed as the landing page. (**Figure 20**)

NOTE: Below the “Active profiles” heading are listed the profiles for connected devices. If no profiles are present, then the wiring, baud rate, and DIP switch settings must be checked, because there is a problem with device communications. All the active profiles must show the correct Node-ID’s before proceeding.

NOTE: If multiple devices are connected to the ProtoNode, set the BACnet Virtual Server Nodes field to “Yes”; otherwise leave the field on the default “No” setting.

- To access the Web GUI, click on the “Diagnostics & Debugging” button in the bottom right side of the page.

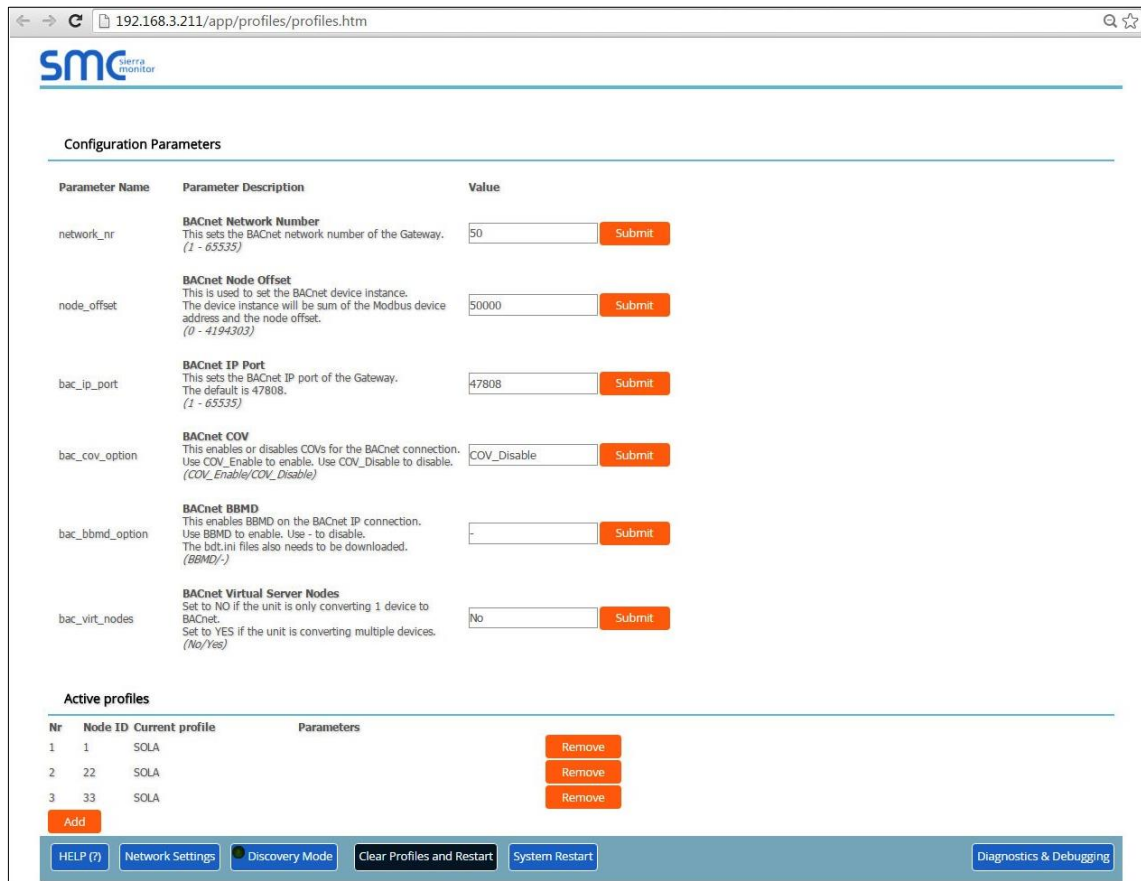

Figure 20: Web Configurator Screen

- From the Web GUI’s landing page, click on “Setup” to expand the navigation tree. Then select “Network Settings” to access the IP Settings menu. (**Figure 21**)

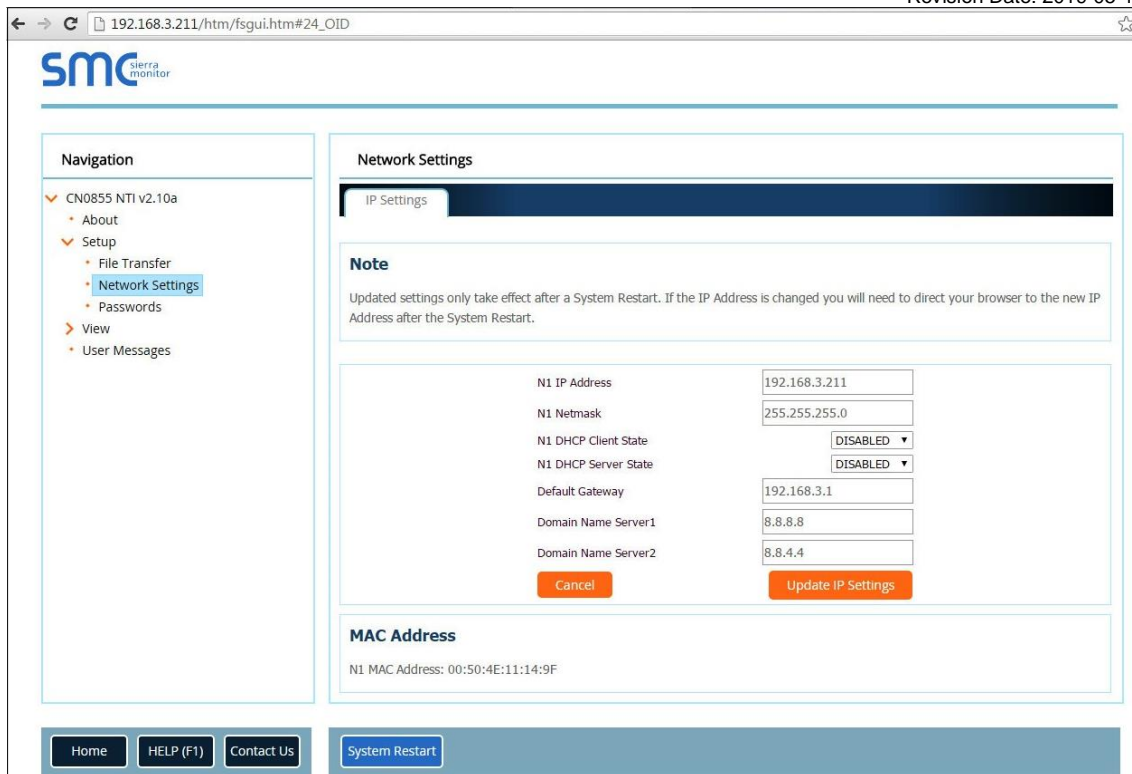

Figure 21: Changing IP Address via Web GUI

- Modify the IP Address (N1 IP Address field) of the ProtoNode Ethernet port.
- If necessary, change the Netmask (N1 Netmask field).
- Type in a new Subnet Mask.
- If necessary, change the IP Gateway (Default Gateway field).
- Type in a new IP Gateway.

NOTE: If the ProtoNode is connected to a router, the IP Gateway of the ProtoNode should be set to the IP Address of that router.

- Reset ProtoNode.
- Unplug Ethernet cable from PC and connect it to the network hub or router.
- **Record the IP Address assigned to the ProtoNode for future reference.**

5 BACNET MS/TP AND BACNET/IP: SETTING NODE_OFFSET TO ASSIGN SPECIFIC DEVICE INSTANCES

- After setting a local PC to the same subnet as the ProtoNode (**Section 4.1**), open a web browser on the PC and enter the IP Address of the ProtoNode; the default address is 192.168.1.24.
- If the IP Address of the ProtoNode has been changed by previous configuration, the assigned IP Address will need to be obtained from the network administrator.
- The Web Configurator will be displayed as the landing page. (**Figure 22**)
- Node_Offset field will be presented displaying the current value (default = 50,000).
- Change the value of Node_Offset to establish the desired Device Instance values, and click SUBMIT.
 - Given that: **Device Instance = Node_Offset + Modbus Node_ID**
 - Then: **Node_Offset (required) = Device Instance (desired) – Modbus Node_ID**

For example, if the desired Device Instance for the 1st device is 1,001:

- Device 1 has a Modbus Node-ID of 1
- Device 2 has a Modbus Node-ID of 22
- Device 3 has a Modbus Node-ID of 33
- **Node_Offset (required) = 1,001 – (Modbus Node_ID) = 1,001 – 1 = 1,000**

NOTE: The Node_Offset value will be applied to all devices.

- Device 1 Instance will then be = 1,000 + Modbus Node_ID = 1,000 + 1 = 1,001
- Device 2 Instance will then be = 1,000 + Modbus Node_ID = 1,000 + 22 = 1,022
- Device 3 Instance will then be = 1,000 + Modbus Node_ID = 1,000 + 33 = 1,033



Figure 22: Web Configurator screen with Active Profiles

6 HOW TO START THE INSTALLATION OVER: CLEARING PROFILES

- After setting a local PC to the same subnet as the ProtoNode (**Section 4.1**), open a web browser on the PC and enter the IP Address of the ProtoNode; the default address is 192.168.1.24.
- If the IP Address of the ProtoNode has been changed by previous configuration, the assigned IP Address will need to be obtained from the network administrator.
- The Web Configurator will be displayed as the landing page.
- **At the bottom-left of the page, click the “Clear Profiles and Restart” button.**
- Once restart is complete, all past profiles discovered and/or added via Web configurator are deleted. The unit can now be reinstalled.

7 LONWORKS (FPC-N35): COMMISSIONING PROTONODE ON A LONWORKS NETWORK

Commissioning may only be performed by the LonWorks administrator.

7.1 Commissioning ProtoNode FPC-N35 on a LonWorks Network

The User will be prompted by the LonWorks Administrator to hit the Service Pin on the ProtoNode FPC-N35 at the correct step of the Commissioning process which is different for each LonWorks Network Management Tool.

- If an XIF file is required, see steps in **Section 7.1.1** to generate XIF.



Figure 23: LonWorks Service Pin Location

7.1.1 Instructions to Download XIF File from ProtoNode FPC-N35 Using Browser

- Connect a CAT5 Ethernet cable (Straight through or Cross-Over) between the PC and ProtoNode.
- The Default IP Address of ProtoNode is **192.168.1.24**, Subnet Mask is **255.255.255.0**. If the PC and ProtoNode are on different IP Networks, assign a static IP Address to the PC on the 192.168.1.xxx network.
- For Windows XP:



Right-click on Local Area Connection > Properties

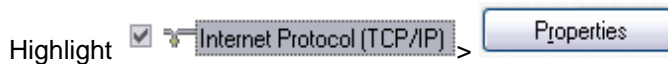

- For Windows 7:

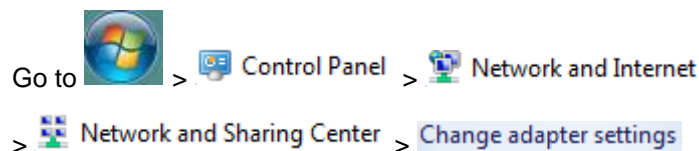

Right-click on Local Area Connection > Properties

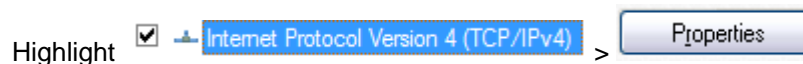

- For Windows XP and Windows 7, select: Use the following IP Address.

Use the following IP address:

IP address:

Subnet mask:

Default gateway:

- Click twice.
- Open a web browser and go to the following address: [IP Address of ProtoCessor]/fserver.xif.
 - Example: 192.168.1.24/fserver.xif
- If the web browser prompts to save the file, save the file onto the local PC. If the web browser displays the xif file as a web page, save the file onto the local PC as “fserver.xif”.

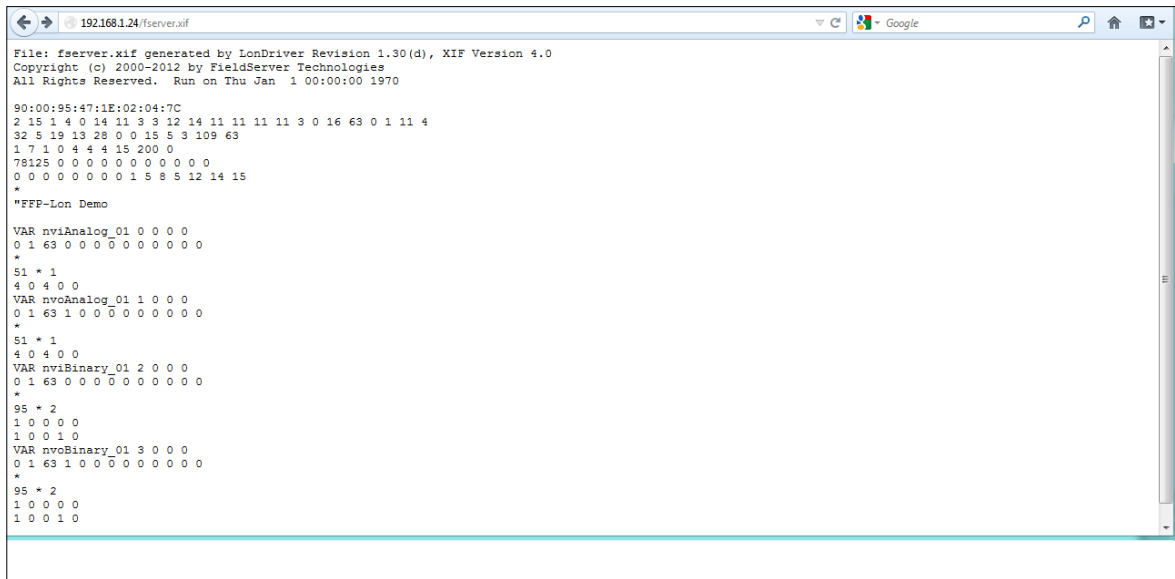

Figure 24: Sample of Fserver.XIF File Generated

8 CAS BACNET EXPLORER FOR VALIDATING PROTONODE IN THE FIELD

ProtoCessor has arranged a complementary 2 week fully functional copy of CAS BACnet Explorer (through Chipkin Automation) that can be used to validate BACnet MS/TP and/or BACnet/IP communications of ProtoNode in the field without having to have the BMS Integrator on site. A serial or USB to RS-485 converter is needed to test BACnet MS/TP.

8.1 Downloading the CAS Explorer and Requesting an Activation Key

- To request the complementary BACnet CAS key, go to <http://app.chipkin.com/activation/twoweek/> and fill in all the information. Enter Vendor Code "NTI2BACnet". Once completed, the email address that was submitted will be registered.

Request a two week account activation

You have two choices

1. Activate your account for two weeks
 To request a two week account activation, simply complete this form and request a new product key from within the CAS BACnet Explorer.
 Note: Your contact info will be used by chipkin to contact you. If your contact info is invalid or you are unreachable your account will be revoked.

Name:

Company:

Address:

Phone number:

Email Address:

Vendor code:

Product: CAS BACnet Explorer

1. Purchase
 You can buy the CAS BACnet Explorer to get a full account from If you have one, you can use your discount coupon on the web page. [Visit this page](#)

Feel free to [contact us](#) with any questions you may have.

Figure 25: Downloading the CAS Explorer

- Go to the following web site, download and install the CAS BACnet Explorer to the local PC: <http://www.chipkin.com/technical-resources/cas-bacnet-explorer/>.
- Open CAS BACnet Explorer; in the CAS Activation form, enter the email address that was registered and click on "Request a key". The CAS key will then be emailed to the registered address. Cut/paste key from email into the Product key field and click "Activate".

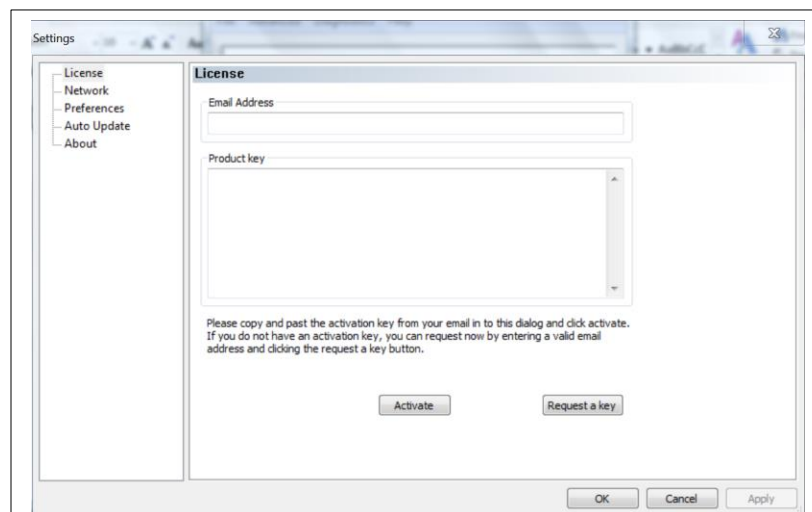

Figure 26: Requesting CAS Activation Key

8.2 CAS BACnet Setup

These are the instructions to set CAS Explorer up for the first time on BACnet MS/ST and BACnet/IP.

8.2.1 CAS BACnet MS/TP Setup

- Using the serial or USB to RS-485 converter, connect it to the local PC and the 3 Pin BACnet MS/TP connector on ProtoNode FPC-N34.
- In CAS Explorer, do the following:
 - Click on settings
 - Check the BACnet MS/TP box and uncheck the BACnet/IP and BACnet Ethernet boxes
 - Set the BACnet MS/TP MAC address to 0
 - Set the BACnet MS/TP Baud Rate to 38400
 - Click Ok
 - On the bottom right-hand corner, make sure that the BACnet MS/TP box is green
 - Click on discover
 - Check all 4 boxes
 - Click Send

8.2.2 CAS BACnet BACnet/IP Setup

- See **Section 4.2** to set the IP Address and subnet of the PC that will be running the CAS Explorer.
- Connect a straight through or cross Ethernet cable from the PC to ProtoNode.
- In CAS Explorer, do the following:
 - Click on settings
 - Check the BACnet/IP box and uncheck the BACnet MS/TP and BACnet Ethernet boxes
 - In the “Select a Network Device” box, select the network card of the PC
 - Click Ok
 - On the bottom right-hand corner, make sure that the BACnet/IP box is green
 - Click on discover
 - Check all 4 boxes
 - Click Send

9 NTI FIELD WIRING DIAGRAMS

9.1 Tft-Lx ProtoNode RS485 Wiring, Single S7999C (White Display)

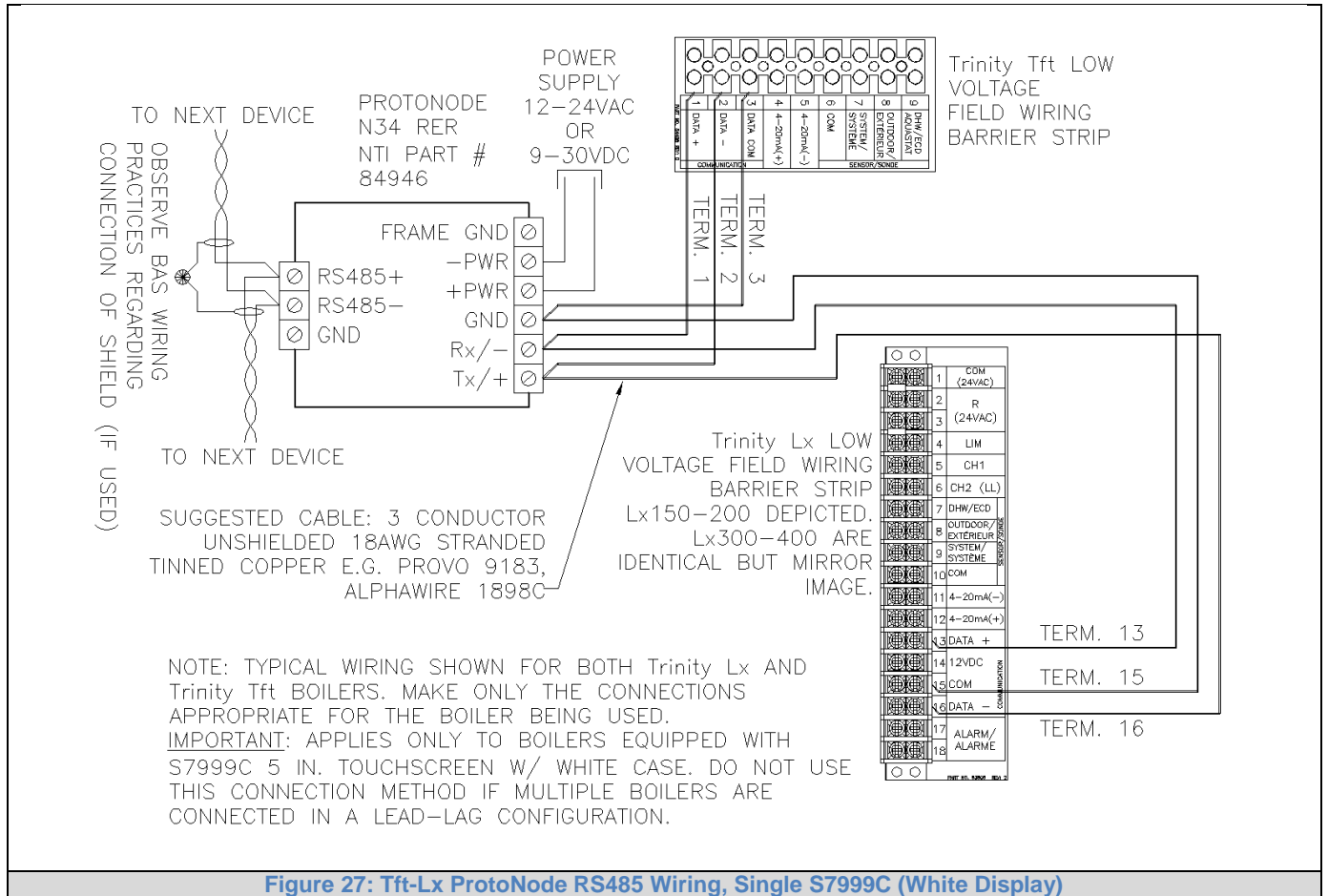
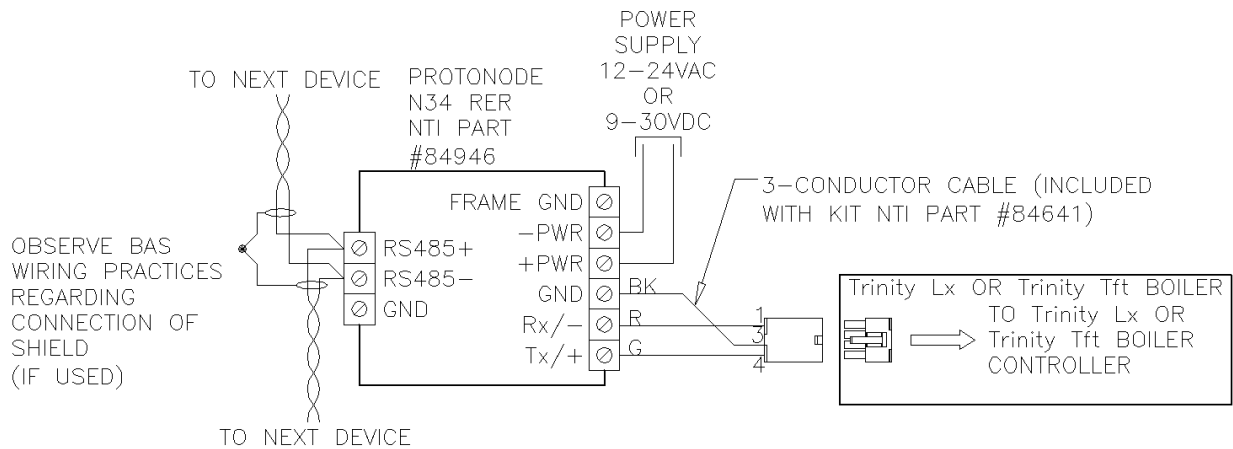

Figure 27: Tft-Lx ProtoNode RS485 Wiring, Single S7999C (White Display)

9.2 Tft-Lx ProtoNode RS485 Wiring, Multiple S7999C (White Display)



NOTE:

1. USE THIS METHOD FOR CONNECTION TO AN INDIVIDUAL BOILER WHEN MULTIPLE Trinity Lx OR Trinity Tft BOILERS ARE CONNECTED IN A LEAD LAG CONFIGURATION.
2. **IMPORTANT:** APPLIES ONLY TO BOILERS EQUIPPED WITH S7999C 5 IN. TOUCHSCREEN W/ WHITE CASE.
3. TYPICAL OF UP TO MAXIMUM OF 8 BOILERS. EACH BOILER MUST HAVE A UNIQUE MODBUS ADDRESS.
4. TO CONNECT:
 - a. SECURE WIRES OF THE CABLE INCLUDED WITH KIT TO THE SCREW TERMINALS OF THE 6-TERMINAL BLOCK.
 - b. UNPLUG CABLE FROM CONTROL TO DISPLAY.
 - c. PLUG 4-POSITION MOLEX MINIFIT JR. PLUG INTO CONNECTOR OF CABLE CONNECTED TO THE BOILER CONTROLLER.

Figure 28: Tft-Lx ProtoNode RS485 Wiring, Multiple S7999C (White Display)

9.3 Tft-Lx ProtoNode RS485 Wiring, S7999D (Black Display)

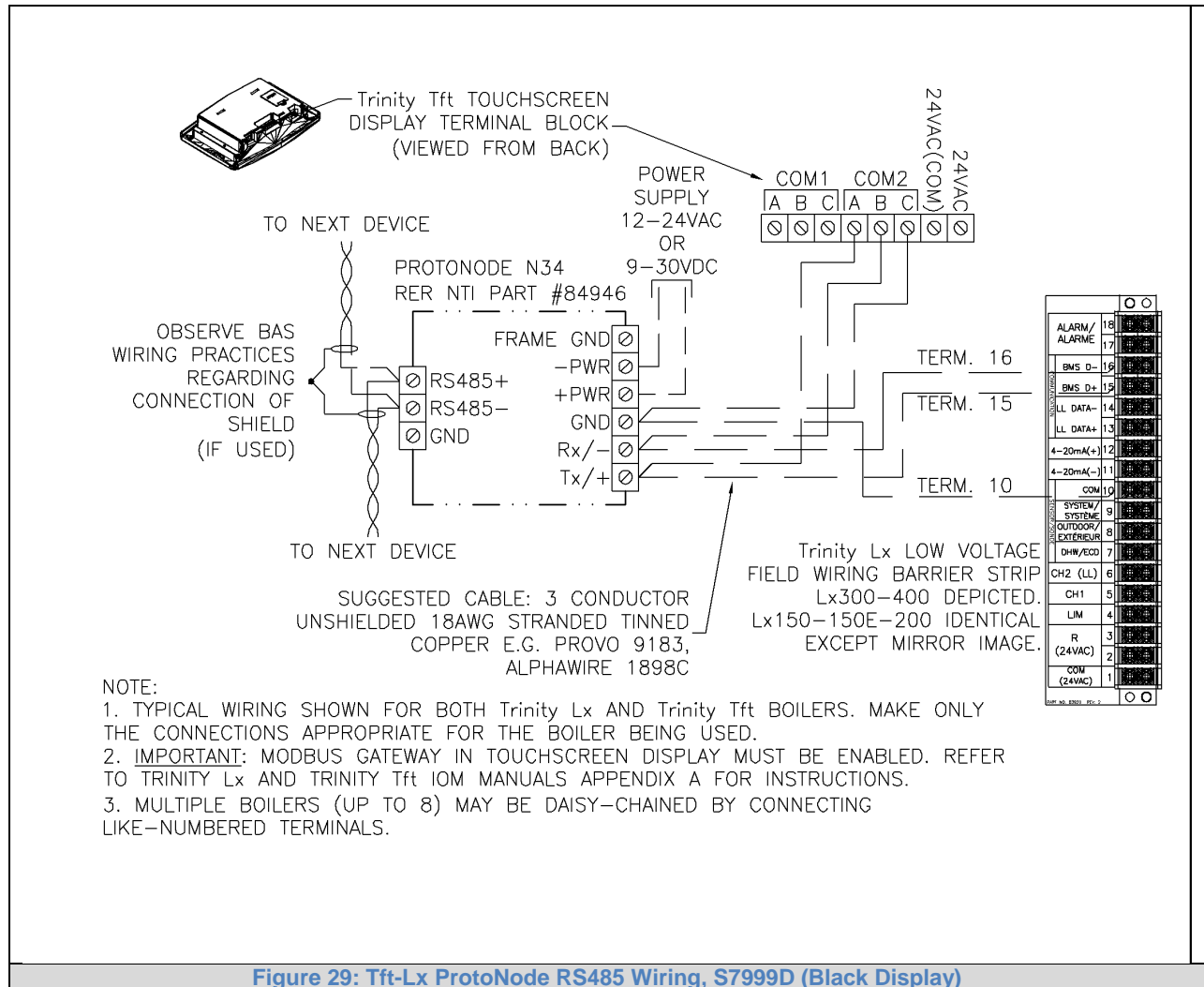

Figure 29: Tft-Lx ProtoNode RS485 Wiring, S7999D (Black Display)

9.4 Lx Commercial ProtoNode RS485 Wiring, Single S7999C (White Display)

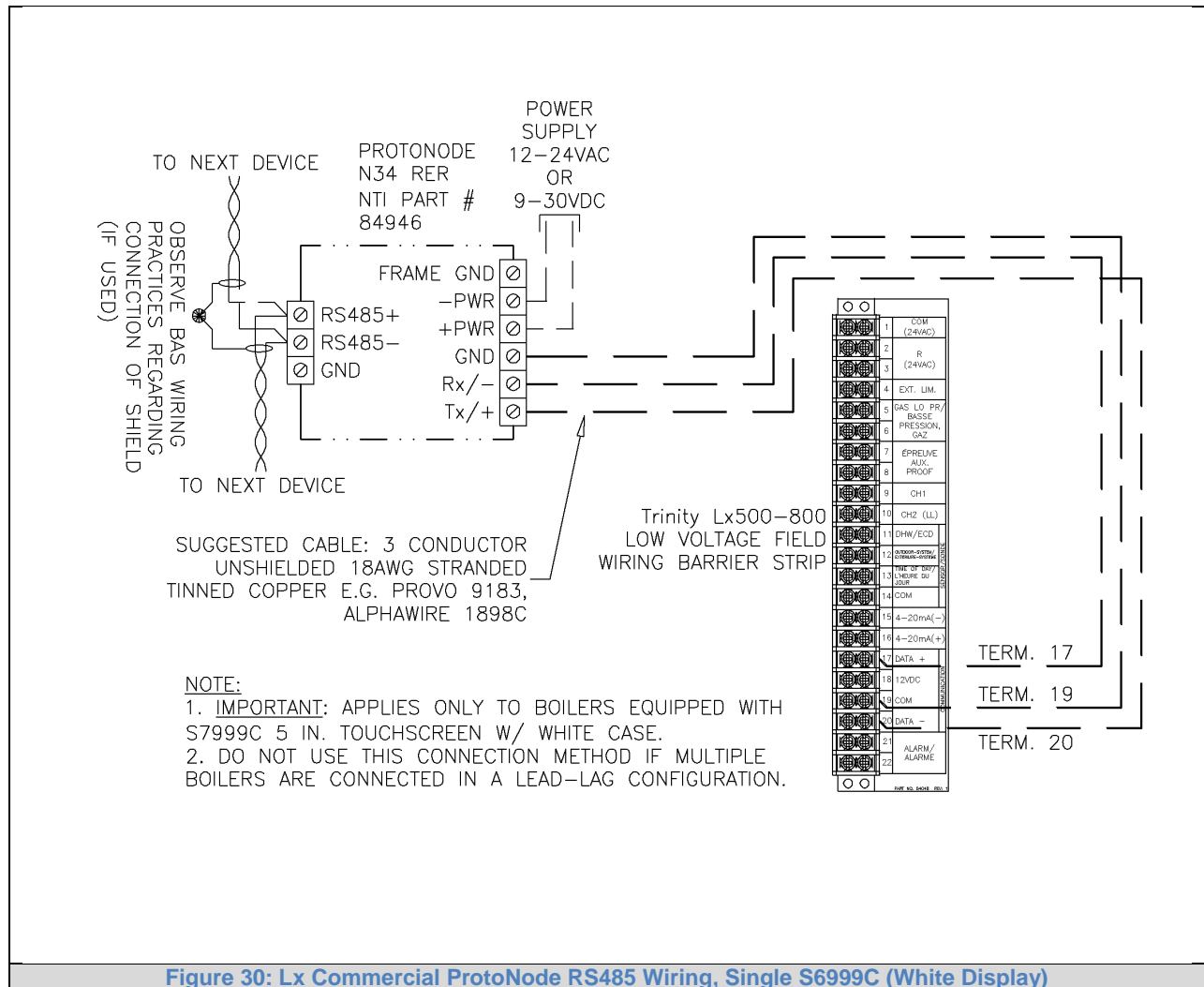

Figure 30: Lx Commercial ProtoNode RS485 Wiring, Single S6999C (White Display)

9.5 Lx Commercial ProtoNode RER RS485 Wiring, S7999D (Black Display)

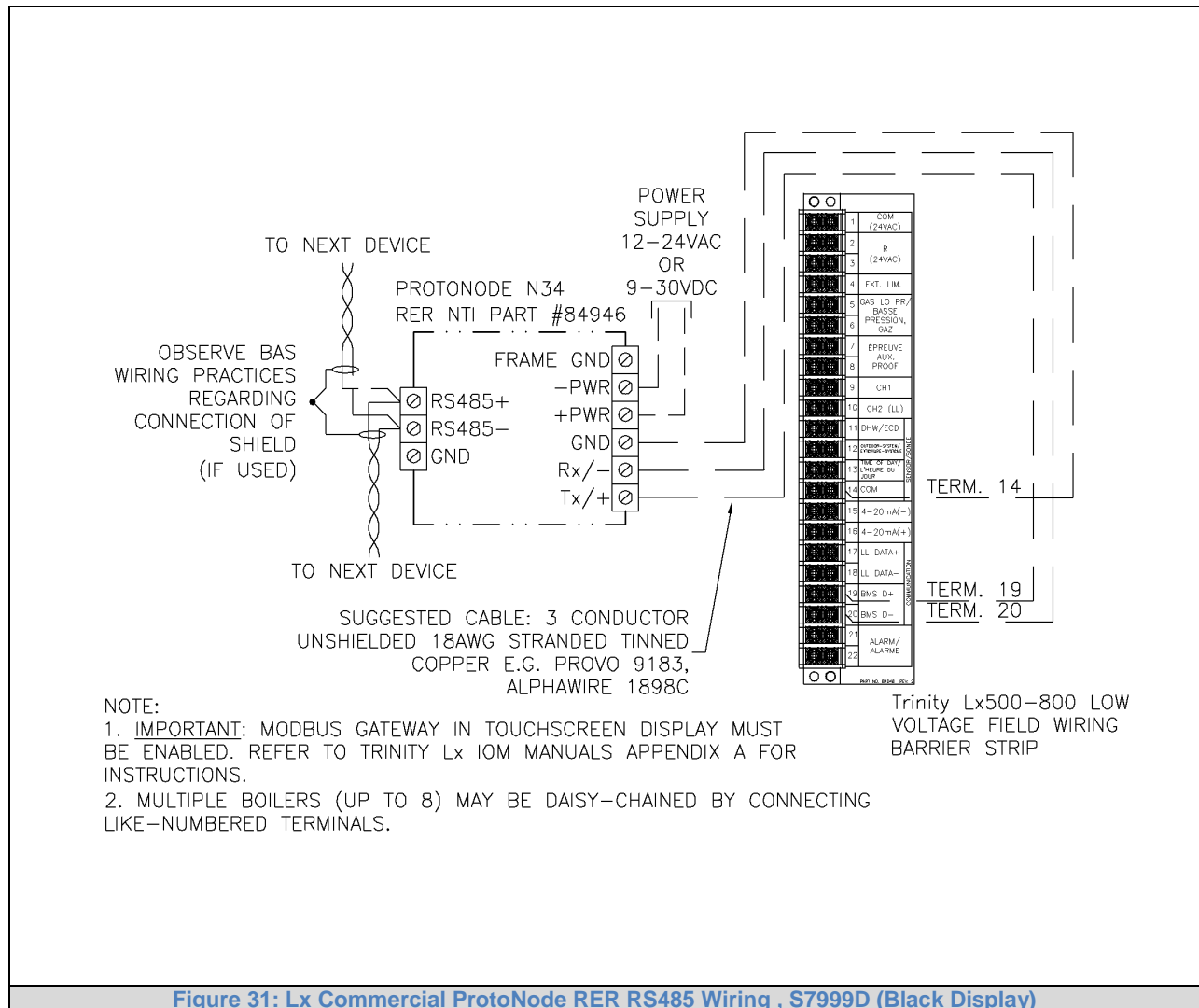

Figure 31: Lx Commercial ProtoNode RER RS485 Wiring , S7999D (Black Display)

9.6 FTG ProtoNode RER RS485 Wiring, S7999D (Black Display)

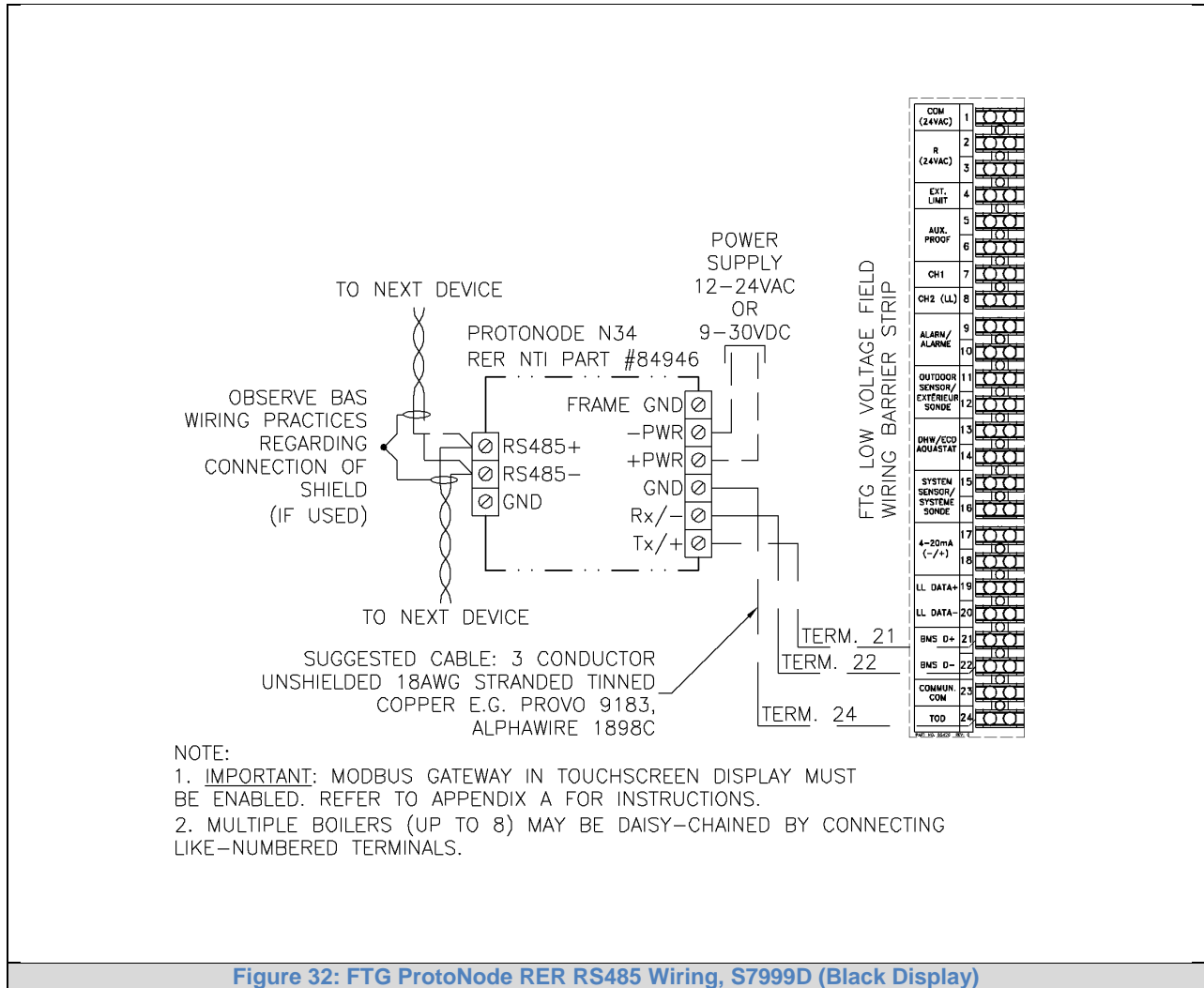

Figure 32: FTG ProtoNode RER RS485 Wiring, S7999D (Black Display)

Appendix A. Troubleshooting

Appendix A.1. Lost or Incorrect IP Address

- Ensure that FieldServer Toolbox is loaded onto the local PC. If not, download FieldServer-Toolbox.zip on the Sierra Monitor webpage, under Customer Care-Resource Center, Software Downloads:
<http://www.sierramonitor.com/customer-care/resource-center?filters=software-downloads>
- Extract the executable file and complete the installation.



Figure 33: Ethernet Port Location

- Disable any wireless Ethernet adapters on the PC/Laptop.
- Disable firewall and virus protection software if possible.
- Connect a standard CAT5 Ethernet cable between the PC and ProtoNode.
- Double click on the FS Toolbox Utility.
- Check IP Addresses from the Device listings.

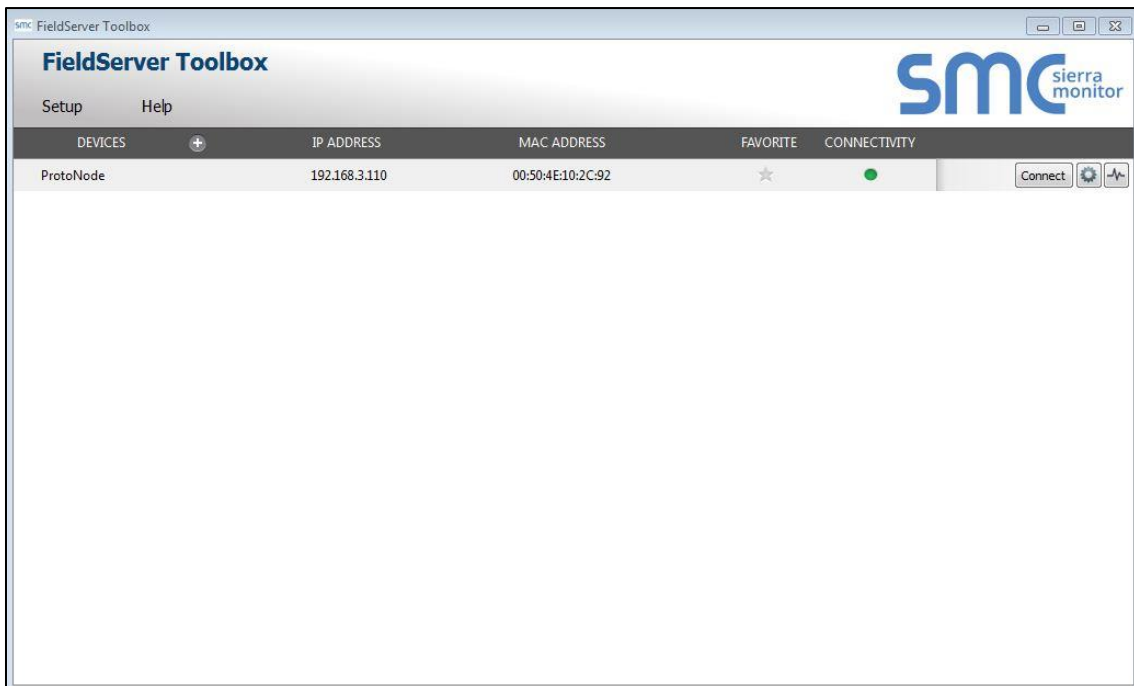

- Correct IP Address(es) by right clicking the settings icon  and changing the IP Address.

Appendix A.2. Viewing Diagnostic information

- Type the IP Address of the ProtoNode into the web browser or use the FieldServer Toolbox to connect to the ProtoNode.
- Click on Diagnostics and Debugging Button, then click on view, and then on connections.
- If there are any errors showing on the Connection page, please refer to [Appendix A.3](#) for the relevant wiring and settings.

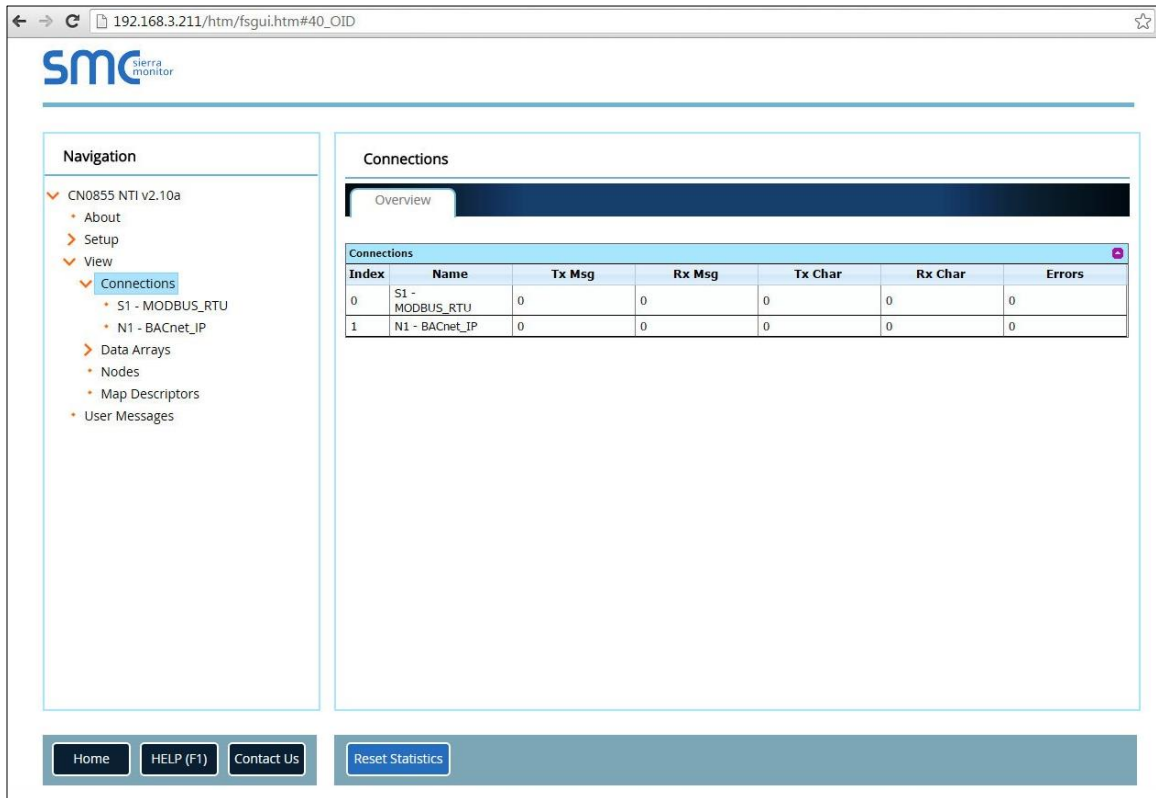

Figure 34: Error messages screen

Appendix A.3. Check Wiring and Settings

- No COMS on Modbus RTU side. If Tx/Rx are not flashing rapidly then there is a COM issue on the Modbus side. To fix this problem, check the following:
 - Visual observations of LEDs on ProtoNode ([Appendix A.6](#))

- Check baud rate, parity, data bits, stop bits
- Check Modbus device address
- Verify wiring
- Verify all the Modbus RTU devices that were discovered in Web Configurator (**Section 5**)
- Field COM problems:
 - Visual observations of LEDs on ProtoNode (**Appendix A.6**)
 - Visual dipswitch settings (using correct baud rate and device instance)
 - Verify IP Address setting
 - Verify wiring

If the problem still exists, a Diagnostic Capture needs to be taken and sent to Sierra Monitor Corporation. (Appendix A.4**)**

Appendix A.4. Take Diagnostic Capture With the FieldServer Utilities

- **Once the Diagnostic Capture is complete, email it to support@sierramonitor.com. The Diagnostic Capture will allow us to rapidly diagnose the problem.**
- Ensure that FieldServer Toolbox is Loaded on the PC that is currently being used, or download FieldServer-Toolbox.zip on the Sierra Monitor Corporation webpage, under Customer Care-Resource Center, Software Downloads:
<http://www.sierramonitor.com/customer-care/resource-center?filters=software-downloads>
- Extract the executable file and complete the installation.

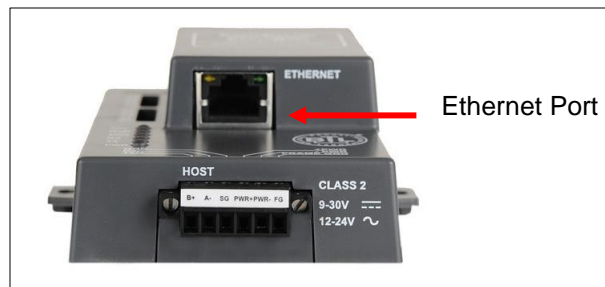
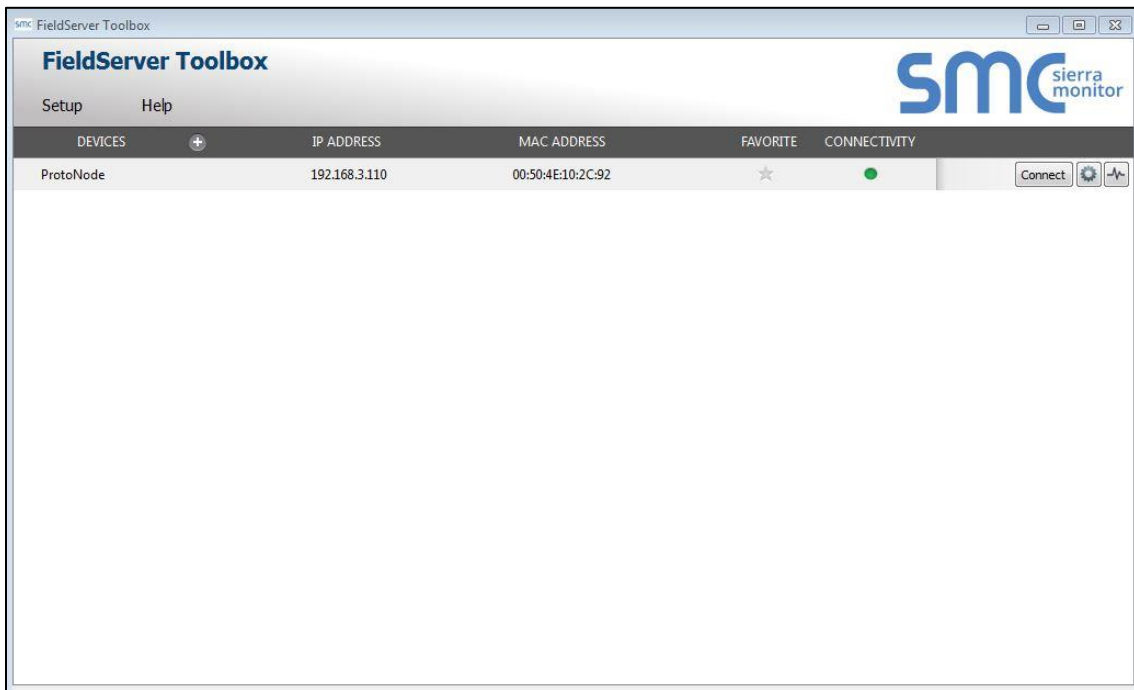

Figure 35: Ethernet Port Location

- Disable any wireless Ethernet adapters on the PC/Laptop.
- Disable firewall and virus protection software if possible.
- Connect a standard Cat5 Ethernet cable between the PC and ProtoNode.
- Double click on the FS Toolbox Utility.

- **Step 1: Take a Log**

- Click on the diagnose icon  of the desired device.



- Select full Diagnostic.

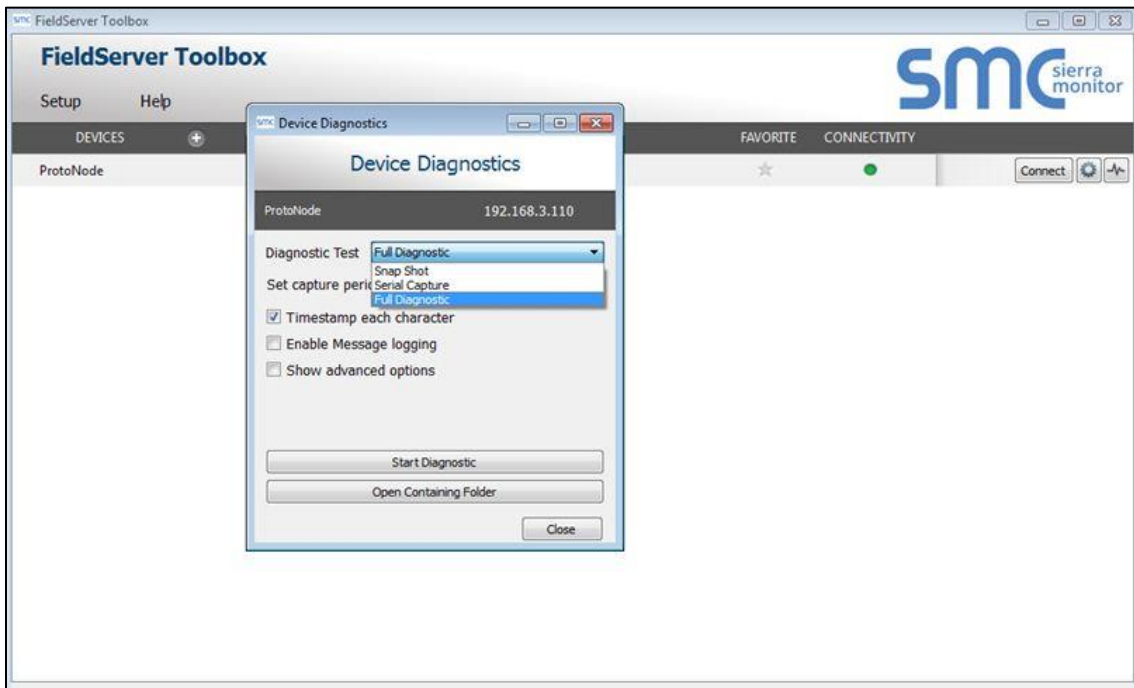

- If desired, the default capture period can be changed.

- Click on “Start Diagnostic”.

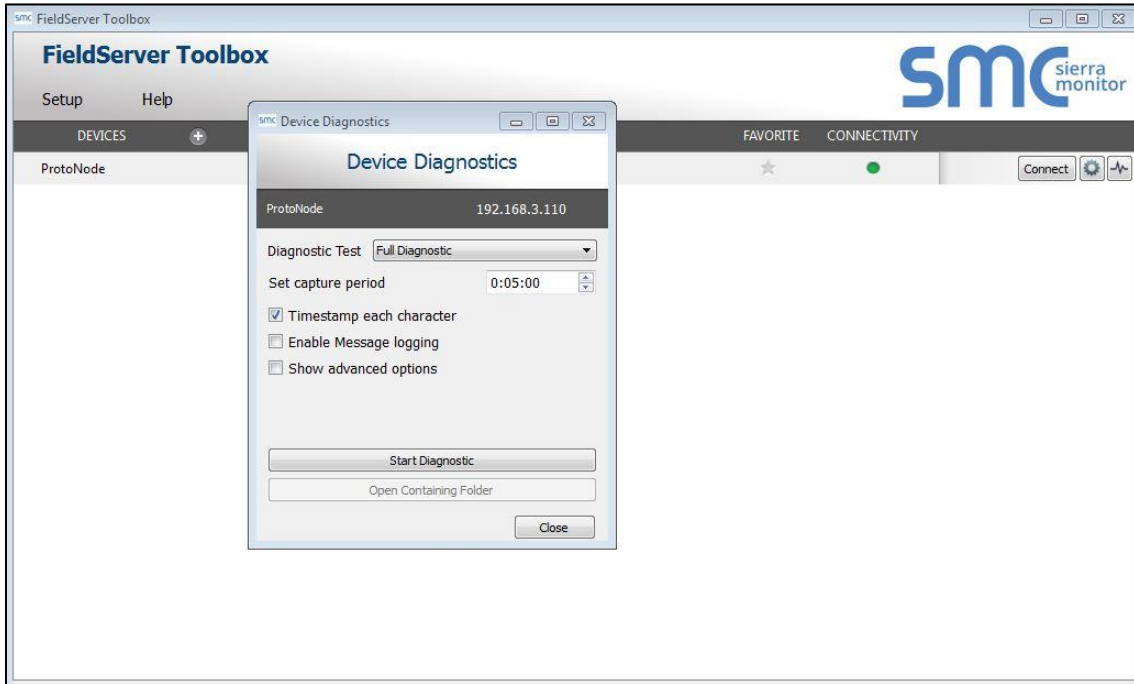

- Wait for Capture period to finish. Diagnostic Test Complete window will appear.
- **Step 2:** Send Log
 - Once the Diagnostic test is complete, a .zip file will be saved on the PC.

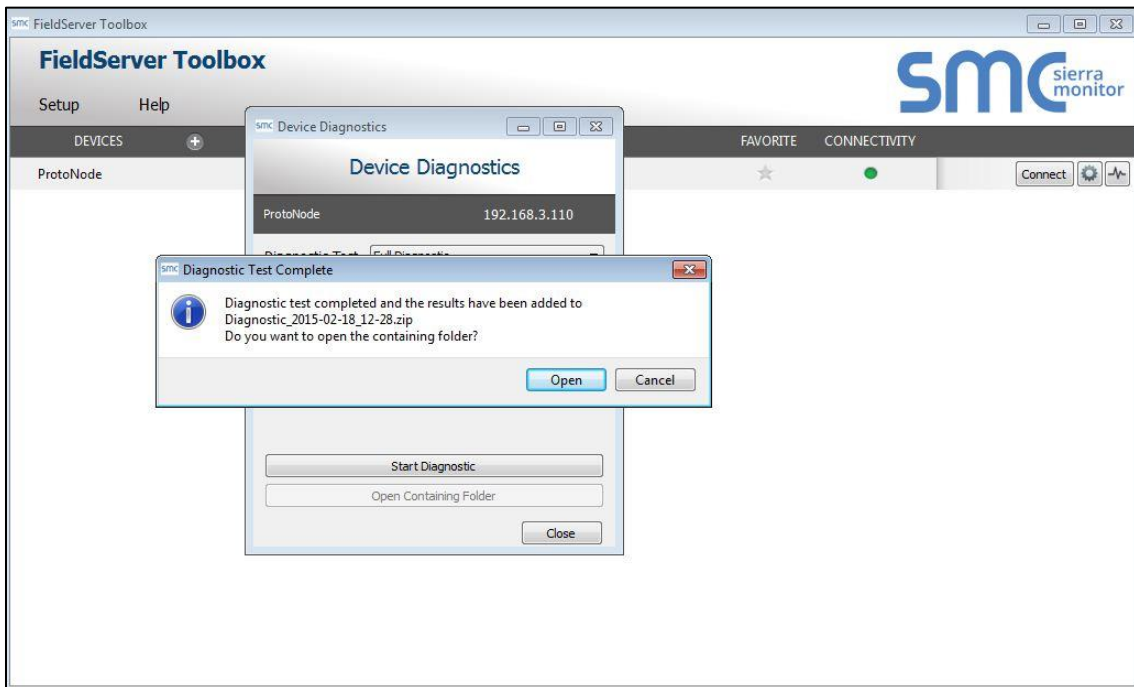

- Choose open to launch explorer and have it point directly at the correct folder. Send the Diagnostic zip file to support@sierramonitor.com.

Diagnostic_2014-07-17_20-15.zip 2014/07/17 20:16 zip Archive 676 KB

Appendix A.5. BACnet: Setting Network_Number for more than one ProtoNode on Subnet

For both BACnet MS/TP and BACnet/IP, if more than one ProtoNode is connected to the same subnet, they must be assigned unique Network_Number values.

On the main Web Configuration screen, update the Network Number with the “network_nr” field and click submit. The default value is 50.

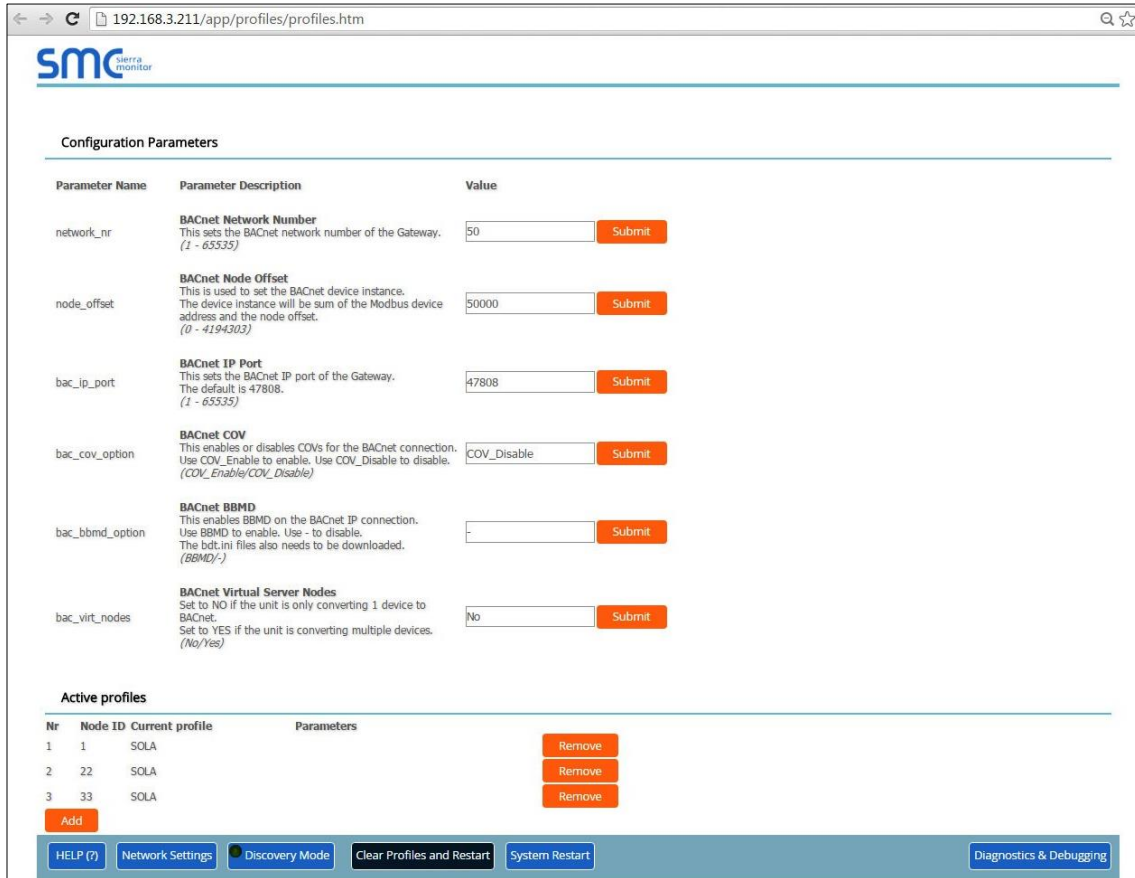
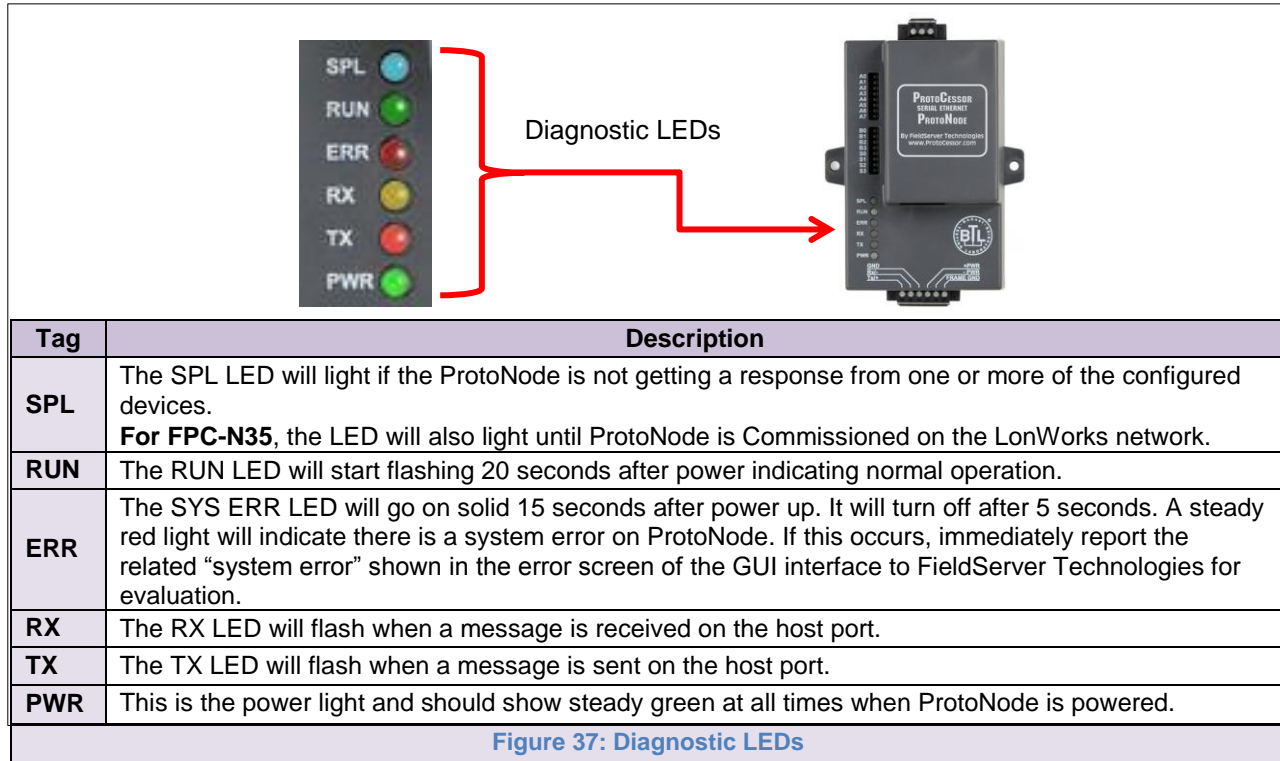

Figure 36: Web Configurator – Setting Network Number for BACnet

Appendix A.6. LED Diagnostics for Communications Between ProtoNode and Devices

Please see the diagram below for ProtoNode FPC-N34 and FPC-N35 LED Locations.



Appendix A.7. Passwords

Access to the ProtoNode can be restricted by enabling a password. There are 2 access levels defined by 2 account names: Admin and User.

- The Admin account has unrestricted access to the ProtoNode.
- The User account can view any ProtoNode information, but cannot make any changes or restart the ProtoNode.

The password needs to be a minimum of eight characters and **is case sensitive**.

If the password is lost, click cancel on the password authentication popup window, and e-mail the Password recovery token to support@sierramonitor.com to receive a temporary password from the Sierra Monitor support team. Access the ProtoNode to set a new password.



Appendix B. Vendor Information – NY Thermal

Appendix B.1. Sola Modbus RTU Mappings to BACnet, Metasys N2 and LonWorks

| Point Name | BACnet Object Type | BACnet Object ID | N2 Data Type | N2 Point Address | LonWorks Name | LonWorks SNVT |
|---------------------------|--------------------|------------------|--------------|------------------|------------------|------------------|
| Outlet Temp (S3S4 Sensor) | AI | 1 | AI | 1 | nvoOutletTmp_XXX | SNVT_temp_p |
| Fan Speed | AI | 2 | AI | 2 | nvoFanSp_XXX | SNVT_count_inc_f |
| Flame Signal | AI | 3 | AI | 3 | nvoFlmSig_XXX | SNVT_count_inc_f |
| Inlet Temp (S1 Sensor) | AI | 4 | AI | 4 | nvoInletTmp_XXX | SNVT_temp_p |
| DHW Temp (S6 Sensor) | AI | 5 | AI | 5 | nvoDHWTmp_XXX | SNVT_temp_p |
| Outdoor Temp (S5 Sensor) | AI | 6 | AI | 6 | nvoOutdrTmp_XXX | SNVT_temp_p |
| Stack Temp (S8S9 Sensor) | AI | 7 | AI | 7 | nvoStackTmp_XXX | SNVT_temp_p |
| 4-20mA Input | AI | 8 | AI | 8 | nvo4_20Input_XXX | SNVT_count_inc_f |
| Firing Rate | AV | 1 | AO | 1 | nvoFirRate_XXX | SNVT_count_inc_f |
| Active CH Setpoint | AV | 2 | AO | 2 | nvoActCHSP_XXX | SNVT_temp_p |
| Active DHW Setpoint | AV | 3 | AO | 3 | nvoActDHWSP_XXX | SNVT_temp_p |
| Active LL Setpoint | AV | 4 | AO | 4 | nvoActLLSP_XXX | SNVT_temp_p |
| Active CH Op Point | AV | 5 | AO | 5 | nvoActCHOpPt_XXX | SNVT_temp_p |
| Active DHW Op Point | AV | 6 | AO | 6 | nvoAcDHWOpPt_XXX | SNVT_temp_p |
| Active LL Op Point | AV | 7 | AO | 7 | nvoActLLOpPt_XXX | SNVT_temp_p |
| Active Sys Op Point | AV | 8 | AO | 8 | nvoAcSysOpPt_XXX | SNVT_temp_p |
| Active Sys Setpoint | AV | 9 | AO | 9 | nvoActSysSP_XXX | SNVT_temp_p |
| Active Sys On Hysteresis | AV | 10 | AO | 10 | nvoAcSyOnHys_XXX | SNVT_temp_p |
| Active Sys Off Hysteresis | AV | 11 | AO | 11 | nvoAcSyOfHys_XXX | SNVT_temp_p |
| Burner Cycle Count | AV | 12 | AO | 12 | nvoBrnCycCt_XXX | SNVT_count_inc_f |
| Burner Run Time | AV | 13 | AO | 13 | nvoBrnRunTim_XXX | SNVT_time_hour |
| CH Pump Cycle Count | AV | 14 | AO | 14 | nvoCHPmpCyCt_XXX | SNVT_count_inc_f |
| DHW Pump Cycle Count | AV | 15 | AO | 15 | nvoDHWpMcyCt_XXX | SNVT_count_inc_f |
| Boiler Pump Cycle Count | AV | 16 | AO | 16 | nvoBlrPmCyCt_XXX | SNVT_count_inc_f |
| CH Max Mod Rate | AV | 17 | AO | 17 | nvoCHMxMdRat_XXX | SNVT_count_inc_f |



| Point Name | BACnet Object Type | BACnet Object ID | N2 Data Type | N2 Point Address | LonWorks Name | LonWorks SNVT |
|----------------------------|--------------------|------------------|--------------|------------------|-------------------|------------------|
| DHW Max Mod Rate | AV | 18 | AO | 18 | nvoDHWxMdRt_XXX | SNVT_count_inc_f |
| Min Mod Rate | AV | 19 | AO | 19 | nvoMnModRate_XXX | SNVT_count_inc_f |
| Lightoff Rate | AV | 20 | AO | 20 | nvoLitOffRat_XXX | SNVT_count_inc_f |
| Manual Firing Rate | AV | 21 | AO | 21 | nvoManFirRat_XXX | SNVT_count_inc_f |
| CH Setpoint | AV | 22 | AO | 22 | nvi/nvoCHSP_XXX | SNVT_temp_p |
| CH TOD Setpoint | AV | 23 | AO | 23 | nvoCHTODSP_XXX | SNVT_temp_p |
| CH On Hysteresis | AV | 24 | AO | 24 | nvoCHOnHys_XXX | SNVT_temp_p |
| CH Off Hysteresis | AV | 25 | AO | 25 | nvoCHOffHys_XXX | SNVT_temp_p |
| Postpurge Time | AV | 26 | AO | 26 | nvoPstPrgTim_XXX | SNVT_time_sec |
| DHW Priority Override Time | AV | 27 | AO | 27 | nvoDHWPrOvTm_XXX | SNVT_time_sec |
| DHW Setpoint | AV | 28 | AO | 28 | nvi/nvoDHWSP_XXX | SNVT_temp_p |
| DHW TOD Setpoint | AV | 29 | AO | 29 | nvoDHW TODSP_XXX | SNVT_temp_p |
| DHW On Hysteresis | AV | 30 | AO | 30 | nvoDHWOnHys_XXX | SNVT_temp_p |
| DHW Off Hysteresis | AV | 31 | AO | 31 | nvoDHWOffHys_XXX | SNVT_temp_p |
| Outlet High Limit Setpoint | AV | 32 | AO | 32 | nvoOutHiLmSP_XXX | SNVT_temp_p |
| Stack Limit Setpoint | AV | 33 | AO | 33 | nvoStckLimSP_XXX | SNVT_temp_p |
| Delta-T Delay | AV | 34 | AO | 34 | nvoDelTDel_XXX | SNVT_time_sec |
| T-Rise Delay | AV | 35 | AO | 35 | nvoTRiseDel_XXX | SNVT_time_sec |
| CH ODR Max Outdoor Temp | AV | 36 | AO | 36 | nvoCHODRMxOT_XXX | SNVT_temp_p |
| CH ODR Min Outdoor Temp | AV | 37 | AO | 37 | nvoCHODRMnOT_XXX | SNVT_temp_p |
| CH ODR Low Water Temp | AV | 38 | AO | 38 | nvoCHODRLoWT_XXX | SNVT_temp_p |
| LL CH ODR Max Outdoor Temp | AV | 39 | AO | 39 | nvoLLCHOMxOT_XXX | SNVT_temp_p |
| LL CH ODR Min Outdoor Temp | AV | 40 | AO | 40 | nvoLLCHOMnOT_XXX | SNVT_temp_p |
| LL CH ODR Low Water Temp | AV | 41 | AO | 41 | nvoLLCHOLoWT_XXX | SNVT_temp_p |
| LL CH Setpoint | AV | 42 | AO | 42 | nvi/nvoLLCHSP_XXX | SNVT_temp_p |
| LL TOD CH Setpoint | AV | 43 | AO | 43 | nvoLLTODCHSP_XXX | SNVT_temp_p |
| LL On Hysteresis | AV | 44 | AO | 44 | nvoLLOnHys_XXX | SNVT_temp_p |
| LL Off | AV | 45 | AO | 45 | nvoLLOffHys_XXX | SNVT_temp_p |



| Point Name | BACnet Object Type | BACnet Object ID | N2 Data Type | N2 Point Address | LonWorks Name | LonWorks SNVT |
|--------------------------------|--------------------|------------------|--------------|------------------|------------------|------------------|
| Hysteresis | | | | | | |
| LL P Gain | AV | 46 | AO | 46 | nvoLLPGain_XXX | SNVT_count_inc_f |
| LL I Gain | AV | 47 | AO | 47 | nvoLLIGain_XXX | SNVT_count_inc_f |
| Base Load Common | AV | 48 | AO | 48 | nvoBseLdCom_XXX | SNVT_lev_percent |
| Warm Weather Shutdown Setpoint | AV | 49 | AO | 49 | nvoWmWtShtSP_XXX | SNVT_temp_p |
| LL Add Stage Error Threshold | AV | 50 | AO | 50 | nvoLLStgErTh_XXX | SNVT_temp_p |
| LL Add Stage interstage Delay | AV | 51 | AO | 51 | nvoLLStgInDI_XXX | SNVT_time_sec |
| Lead Rotation Time | AV | 52 | AO | 52 | nvoLdRotTime_XXX | SNVT_time_min |
| Force Lead Rotation Time | AV | 53 | AO | 53 | nvoFrcLdRtTm_XXX | SNVT_time_min |
| Slave 1 Address | AV | 54 | AO | 54 | nvoSlv1Addr_XXX | SNVT_count_inc_f |
| Slave 1 Stage Order | AV | 55 | AO | 55 | nvoSl1StgOrd_XXX | SNVT_count_inc_f |
| Slave 1 Firing Rate | AV | 56 | AO | 56 | nvoSl1FirRat_XXX | SNVT_lev_percent |
| Slave 2 Address | AV | 57 | AO | 57 | nvoSl2Addr_XXX | SNVT_count_inc_f |
| Slave 2 Stage Order | AV | 58 | AO | 58 | nvoSl2StgOrd_XXX | SNVT_count_inc_f |
| Slave 2 Firing Rate | AV | 59 | AO | 59 | nvoSl2FirRat_XXX | SNVT_lev_percent |
| Slave 3 Address | AV | 60 | AO | 60 | nvoSl3Addr_XXX | SNVT_count_inc_f |
| Slave 3 Stage Order | AV | 61 | AO | 61 | nvoSl3StgOrd_XXX | SNVT_count_inc_f |
| Slave 3 Firing Rate | AV | 62 | AO | 62 | nvoSl3FirRat_XXX | SNVT_lev_percent |
| Slave 4 Address | AV | 63 | AO | 63 | nvoSl4Addr_XXX | SNVT_count_inc_f |
| Slave 4 Stage Order | AV | 64 | AO | 64 | nvoSl4StgOrd_XXX | SNVT_count_inc_f |
| Slave 4 Firing Rate | AV | 65 | AO | 65 | nvoSl4FirRat_XXX | SNVT_lev_percent |
| Slave 5 Address | AV | 66 | AO | 66 | nvoSl5Addr_XXX | SNVT_count_inc_f |
| Slave 5 Stage Order | AV | 67 | AO | 67 | nvoSl5StgOrd_XXX | SNVT_count_inc_f |
| Slave 5 Firing Rate | AV | 68 | AO | 68 | nvoSl5FirRat_XXX | SNVT_lev_percent |
| Slave 6 | AV | 69 | AO | 69 | nvoSl6Addr_XXX | SNVT_count_inc_f |



| Point Name | BACnet Object Type | BACnet Object ID | N2 Data Type | N2 Point Address | LonWorks Name | LonWorks SNVT |
|-----------------------------|--------------------|------------------|--------------|------------------|------------------|------------------|
| Address | | | | | | |
| Slave 6 Stage Order | AV | 70 | AO | 70 | nvoSl6StgOrd_XXX | SNVT_count_inc_f |
| Slave 6 Firing Rate | AV | 71 | AO | 71 | nvoSl6FirRat_XXX | SNVT_lev_percent |
| Slave 7 Address | AV | 72 | AO | 72 | nvoSl7Addr_XXX | SNVT_count_inc_f |
| Slave 7 Stage Order | AV | 73 | AO | 73 | nvoSl7StgOrd_XXX | SNVT_count_inc_f |
| Slave 7 Firing Rate | AV | 74 | AO | 74 | nvoSl7FirRat_XXX | SNVT_lev_percent |
| Slave 8 Address | AV | 75 | AO | 75 | nvoSl8Addr_XXX | SNVT_count_inc_f |
| Slave 8 Stage Order | AV | 76 | AO | 76 | nvoSl8StgOrd_XXX | SNVT_count_inc_f |
| Slave 8 Firing Rate | AV | 77 | AO | 77 | nvoSl8FirRat_XXX | SNVT_lev_percent |
| Lead Boiler Address | AV | 78 | AO | 78 | nvoLdBlrAddr_XXX | SNVT_count_inc_f |
| CH 4 mA Water Temp | AV | 79 | AO | 79 | nvoCH4mAWtTp_XXX | SNVT_temp_p |
| CH 20 mA Water Temp | AV | 80 | AO | 80 | nvoC20mAWtTp_XXX | SNVT_temp_p |
| CH ODR Boost Time | AV | 81 | AO | 81 | nvoCHODRBTm_XXX | SNVT_time_sec |
| Rate Assigned To 0V/4mA | AV | 82 | AO | 82 | nvoRtAs0V4mA_XXX | SNVT_lev_percent |
| Lead Lag CH 4Ma Water Temp | AV | 83 | AO | 83 | nvoLLC4MWtTp_XXX | SNVT_temp_p |
| Lead Lag CH 20Ma Water Temp | AV | 84 | AO | 84 | nvoLLC20MWtT_XXX | SNVT_temp_p |
| Lead Lag DHW Setpoint | AV | 85 | AO | 85 | nvoLLDHWSP_XXX | SNVT_temp_p |
| LI CH ODR Boost Time | AV | 86 | AO | 86 | nvoLICHODRBT_XXX | SNVT_time_sec |
| Preferred Outlet High Limit | AV | 87 | AO | 87 | nvoPrOtHiLim_XXX | SNVT_temp_p |
| Preferred Stack Limit | AV | 88 | AO | 88 | nvoPrStkLim_XXX | SNVT_temp_p |
| Preferred Lightoff Rate | AV | 89 | AO | 89 | nvoPrLtOfRte_XXX | SNVT_count_inc_f |
| Interlock/ILK | BI | 1 | DI | 1 | nvoInterlock_XXX | SNVT_switch |
| LCI | BI | 2 | DI | 2 | nvoLCI_XXX | SNVT_switch |
| STAT | BI | 3 | DI | 3 | nvoSTAT_XXX | SNVT_switch |
| Time Of Day (TOD) | BI | 4 | DI | 4 | nvoTimeOfDay_XXX | SNVT_switch |
| Safety Relay | BI | 5 | DI | 5 | nvoSafetyRel_XXX | SNVT_switch |



| Point Name | BACnet Object Type | BACnet Object ID | N2 Data Type | N2 Point Address | LonWorks Name | LonWorks SNVT |
|------------------------------|--------------------|------------------|--------------|------------------|----------------------|---------------|
| Annunciator 1/IAS | BI | 6 | DI | 6 | nvoAnnun1_XXX | SNVT_switch |
| Annunciator 2 | BI | 7 | DI | 7 | nvoAnnun2_XXX | SNVT_switch |
| Annunciator 3 | BI | 8 | DI | 8 | nvoAnnun3_XXX | SNVT_switch |
| Annunciator 4 | BI | 9 | DI | 9 | nvoAnnun4_XXX | SNVT_switch |
| Annunciator 5 | BI | 10 | DI | 10 | nvoAnnun5_XXX | SNVT_switch |
| Annunciator 6 | BI | 11 | DI | 11 | nvoAnnun6_XXX | SNVT_switch |
| Annunciator 7 | BI | 12 | DI | 12 | nvoAnnun7_XXX | SNVT_switch |
| Annunciator 8 | BI | 13 | DI | 13 | nvoAnnun8_XXX | SNVT_switch |
| Pump A | BV | 1 | DO | 1 | nvoPmpA_XXX | SNVT_switch |
| Pump B | BV | 2 | DO | 2 | nvoPmpB_XXX | SNVT_switch |
| Pump C | BV | 3 | DO | 3 | nvoPmpC_XXX | SNVT_switch |
| Spark Ignition | BV | 4 | DO | 4 | nvoSparklgn_XXX | SNVT_switch |
| Pilot Valve | BV | 5 | DO | 5 | nvoPilotVal_XXX | SNVT_switch |
| Alarm | BV | 6 | DO | 6 | nvoAlarm_XXX | SNVT_switch |
| Outlet High Limit | BV | 7 | DO | 7 | nvoOutHiLim_XXX | SNVT_switch |
| Stack Limit | BV | 8 | DO | 8 | nvoStackLim_XXX | SNVT_switch |
| Delta-T Limit | BV | 9 | DO | 9 | nvoDeltaTLim_XXX | SNVT_switch |
| Inversion Limit | BV | 10 | DO | 10 | nvoInversLim_XXX | SNVT_switch |
| T-rise Limit | BV | 11 | DO | 11 | nvoT_riseLim_XXX | SNVT_switch |
| Burner Switch | BV | 12 | DO | 12 | nvoBrnSwitch_XXX | SNVT_switch |
| CH Outdoor Reset Enable | BV | 13 | DO | 13 | nvoCHOtResEn_XXX | SNVT_switch |
| CH Pump Control (Pump C) | BV | 14 | DO | 14 | nvoCHPmpCtrl_XXX | SNVT_switch |
| DHW Pump Control (Pump A) | BV | 15 | DO | 15 | nvoDHWpMctrl_XXX | SNVT_switch |
| Boiler Pump Control (Pump B) | BV | 16 | DO | 16 | nvoBlrPmCtrl_XXX | SNVT_switch |
| CH frost Protect Enable | BV | 17 | DO | 17 | nvoCHFrPrEn_XXX | SNVT_switch |
| DHW frost Protect Enable | BV | 18 | DO | 18 | nvoDHWFrPrEn_XXX | SNVT_switch |
| LL frost Protect Enable | BV | 19 | DO | 19 | nvoLLFrPrEn_XXX | SNVT_switch |
| LL Master Enable | BV | 20 | DO | 20 | nvoLLMastrEn_XXX | SNVT_switch |
| LL CH Outdoor Reset Enable | BV | 21 | DO | 21 | nvoLLCHORsEn_XXX | SNVT_switch |
| CH Enable | BV | 22 | DO | 22 | nvi/nvoCH_Enable_XXX | SNVT_switch |
| DHW Enable | BV | 23 | DO | 23 | nvi/nvoDHWEnable_XXX | SNVT_switch |
| Demand Source | MV | 1 | ADI | 1 | nvoDemandSrc_XXX | SNVT_switch |
| Burner Control Status | MV | 2 | ADI | 2 | nvoBrnCtStat_XXX | SNVT_count |



| Point Name | BACnet Object Type | BACnet Object ID | N2 Data Type | N2 Point Address | LonWorks Name | LonWorks SNVT |
|------------------------------|--------------------|------------------|--------------|------------------|----------------------|---------------|
| Burner Control State | MV | 3 | ADI | 3 | nvoBrCtState_XXX | SNVT_count |
| Lockout Code | MV | 4 | ADI | 4 | nvoLckotCode_XXX | SNVT_count |
| Hold Code | MV | 5 | ADI | 5 | nvoHoldCode_XXX | SNVT_count |
| Firing Rate Control | MV | 6 | ADI | 6 | nvoFrRatCtrl_XXX | SNVT_count |
| CH Demand Switch | MV | 7 | ADI | 7 | nvoCHDemSw_XXX | SNVT_count |
| CH Mod Sensor | MV | 8 | ADI | 8 | nvoCHModSen_XXX | SNVT_count |
| DHW Demand Switch | MV | 9 | ADI | 9 | nvoDHWDemSw_XXX | SNVT_count |
| DHW Mod Sensor | MV | 10 | ADI | 10 | nvoDHWModSen_XXX | SNVT_count |
| LL CH Setpoint Source | MV | 11 | ADI | 11 | nvoLLCHSPSrc_XXX | SNVT_count |
| LL Mod Sensor | MV | 12 | ADI | 12 | nvoLLModSen_XXX | SNVT_count |
| Slave Mode | MV | 13 | ADI | 13 | nvoSlaveMode_XXX | SNVT_count |
| Lead Selection Method | MV | 14 | ADI | 14 | nvoLdSelMeth_XXX | SNVT_count |
| Lag Selection Method | MV | 15 | ADI | 15 | nvoLgSelMeth_XXX | SNVT_count |
| CH Setpoint Source | MV | 16 | ADI | 16 | nvoCHSPSrc_XXX | SNVT_count |
| CH Mod Rate Source | MV | 17 | ADI | 17 | nvoCHMdRtSrc_XXX | SNVT_count |
| Outdoor Temp Source | MV | 18 | ADI | 18 | nvoOtdrTpSrc_XXX | SNVT_count |
| Slave 1 State | MV | 19 | ADI | 19 | nvoSl1State_XXX | SNVT_count |
| Slave 2 State | MV | 20 | ADI | 20 | nvoSl2State_XXX | SNVT_count |
| Slave 3 State | MV | 21 | ADI | 21 | nvoSl3State_XXX | SNVT_count |
| Slave 4 State | MV | 22 | ADI | 22 | nvoSl4State_XXX | SNVT_count |
| Slave 5 State | MV | 23 | ADI | 23 | nvoSl5State_XXX | SNVT_count |
| Slave 6 State | MV | 24 | ADI | 24 | nvoSl6State_XXX | SNVT_count |
| Slave 7 State | MV | 25 | ADI | 25 | nvoSl7State_XXX | SNVT_count |
| Slave 8 State | MV | 26 | ADI | 26 | nvoSl8State_XXX | SNVT_count |
| Most Recent Alert | MV | 27 | ADI | 27 | nvoMstRecAlt_XXX | SNVT_count |
| Warm Weather Shutdown Enable | MV | 28 | ADI | 28 | nvi/nvoWrWtShtEn_XXX | SNVT_count |
| Lead Lag CH Demand Switch | MV | 29 | ADI | 29 | nvoLLCHDemSw_XXX | SNVT_count |
| Lead Lag DHW Demand Switch | MV | 30 | ADI | 30 | nvoLLDHWdMsw_XXX | SNVT_count |



Appendix C. "A" Bank DIP Switch Settings

Appendix C.1. "A" Bank DIP Switch Settings

| Address | A0 | A1 | A2 | A3 | A4 | A5 | A6 | A7 |
|---------|-----|-----|-----|-----|-----|-----|-----|-----|
| 1 | On | Off | Off | Off | Off | Off | Off | Off |
| 2 | Off | On | Off | Off | Off | Off | Off | Off |
| 3 | On | On | Off | Off | Off | Off | Off | Off |
| 4 | Off | Off | On | Off | Off | Off | Off | Off |
| 5 | On | Off | On | Off | Off | Off | Off | Off |
| 6 | Off | On | On | Off | Off | Off | Off | Off |
| 7 | On | On | On | Off | Off | Off | Off | Off |
| 8 | Off | Off | Off | On | Off | Off | Off | Off |
| 9 | On | Off | Off | On | Off | Off | Off | Off |
| 10 | Off | On | Off | On | Off | Off | Off | Off |
| 11 | On | On | Off | On | Off | Off | Off | Off |
| 12 | Off | Off | On | On | Off | Off | Off | Off |
| 13 | On | Off | On | On | Off | Off | Off | Off |
| 14 | Off | On | On | On | Off | Off | Off | Off |
| 15 | On | On | On | On | Off | Off | Off | Off |
| 16 | Off | Off | Off | Off | On | Off | Off | Off |
| 17 | On | Off | Off | Off | On | Off | Off | Off |
| 18 | Off | On | Off | Off | On | Off | Off | Off |
| 19 | On | On | Off | Off | On | Off | Off | Off |
| 20 | Off | Off | On | Off | On | Off | Off | Off |
| 21 | On | Off | On | Off | On | Off | Off | Off |
| 22 | Off | On | On | Off | On | Off | Off | Off |
| 23 | On | On | On | Off | On | Off | Off | Off |
| 24 | Off | Off | Off | On | On | Off | Off | Off |
| 25 | On | Off | Off | On | On | Off | Off | Off |
| 26 | Off | On | Off | On | On | Off | Off | Off |
| 27 | On | On | Off | On | On | Off | Off | Off |
| 28 | Off | Off | On | On | On | Off | Off | Off |
| 29 | On | Off | On | On | On | Off | Off | Off |
| 30 | Off | On | On | On | On | Off | Off | Off |
| 31 | On | On | On | On | On | Off | Off | Off |
| 32 | Off | Off | Off | Off | Off | On | Off | Off |
| 33 | On | Off | Off | Off | Off | On | Off | Off |
| 34 | Off | On | Off | Off | Off | On | Off | Off |
| 35 | On | On | Off | Off | Off | On | Off | Off |
| 36 | Off | Off | On | Off | Off | On | Off | Off |
| 37 | On | Off | On | Off | Off | On | Off | Off |
| 38 | Off | On | On | Off | Off | On | Off | Off |
| 39 | On | On | On | Off | Off | On | Off | Off |
| 40 | Off | Off | Off | On | Off | On | Off | Off |
| 41 | On | Off | Off | On | Off | On | Off | Off |
| 42 | Off | On | Off | On | Off | On | Off | Off |
| 43 | On | On | Off | On | Off | On | Off | Off |
| 44 | Off | Off | On | On | Off | On | Off | Off |
| 45 | On | Off | On | On | Off | On | Off | Off |
| 46 | Off | On | On | On | Off | On | Off | Off |

| Address | A0 | A1 | A2 | A3 | A4 | A5 | A6 | A7 |
|---------|-----|-----|-----|-----|-----|-----|-----|-----|
| 47 | On | On | On | On | Off | On | Off | Off |
| 48 | Off | Off | Off | Off | On | On | Off | Off |
| 49 | On | Off | Off | Off | On | On | Off | Off |
| 50 | Off | On | Off | Off | On | On | Off | Off |
| 51 | On | On | Off | Off | On | On | Off | Off |
| 52 | Off | Off | On | Off | On | On | Off | Off |
| 53 | On | Off | On | Off | On | On | Off | Off |
| 54 | Off | On | On | Off | On | On | Off | Off |
| 55 | On | On | On | Off | On | On | Off | Off |
| 56 | Off | Off | Off | On | On | On | Off | Off |
| 57 | On | Off | Off | On | On | On | Off | Off |
| 58 | Off | On | Off | On | On | On | Off | Off |
| 59 | On | On | Off | On | On | On | Off | Off |
| 60 | Off | Off | On | On | On | On | Off | Off |
| 61 | On | Off | On | On | On | On | Off | Off |
| 62 | Off | On | On | On | On | On | Off | Off |
| 63 | On | On | On | On | On | On | Off | Off |
| 64 | Off | Off | Off | Off | Off | Off | On | Off |
| 65 | On | Off | Off | Off | Off | Off | On | Off |
| 66 | Off | On | Off | Off | Off | Off | On | Off |
| 67 | On | On | Off | Off | Off | Off | On | Off |
| 68 | Off | Off | On | Off | Off | Off | On | Off |
| 69 | On | Off | On | Off | Off | Off | On | Off |
| 70 | Off | On | On | Off | Off | Off | On | Off |
| 71 | On | On | On | Off | Off | Off | On | Off |
| 72 | Off | Off | Off | On | Off | Off | On | Off |
| 73 | On | Off | Off | On | Off | Off | On | Off |
| 74 | Off | On | Off | On | Off | Off | On | Off |
| 75 | On | On | Off | On | Off | Off | On | Off |
| 76 | Off | Off | On | On | Off | Off | On | Off |
| 77 | On | Off | On | On | Off | Off | On | Off |
| 78 | Off | On | On | On | Off | Off | On | Off |
| 79 | On | On | On | On | Off | Off | On | Off |
| 80 | Off | Off | Off | Off | On | Off | On | Off |
| 81 | On | Off | Off | Off | On | Off | On | Off |
| 82 | Off | On | Off | Off | On | Off | On | Off |
| 83 | On | On | Off | Off | On | Off | On | Off |
| 84 | Off | Off | On | Off | On | Off | On | Off |
| 85 | On | Off | On | Off | On | Off | On | Off |
| 86 | Off | On | On | Off | On | Off | On | Off |
| 87 | On | On | On | Off | On | Off | On | Off |
| 88 | Off | Off | Off | On | On | Off | On | Off |
| 89 | On | Off | Off | On | On | Off | On | Off |
| 90 | Off | On | Off | On | On | Off | On | Off |
| 91 | On | On | Off | On | On | Off | On | Off |
| 92 | Off | Off | On | On | On | Off | On | Off |



| Address | A0 | A1 | A2 | A3 | A4 | A5 | A6 | A7 |
|---------|-----|-----|-----|-----|-----|-----|-----|-----|
| 93 | On | Off | On | On | On | Off | On | Off |
| 94 | Off | On | On | On | On | Off | On | Off |
| 95 | On | On | On | On | On | Off | On | Off |
| 96 | Off | Off | Off | Off | Off | On | On | Off |
| 97 | On | Off | Off | Off | Off | On | On | Off |
| 98 | Off | On | Off | Off | Off | On | On | Off |
| 99 | On | On | Off | Off | Off | On | On | Off |
| 100 | Off | Off | On | Off | Off | On | On | Off |
| 101 | On | Off | On | Off | Off | On | On | Off |
| 102 | Off | On | On | Off | Off | On | On | Off |
| 103 | On | On | On | Off | Off | On | On | Off |
| 104 | Off | Off | Off | On | Off | On | On | Off |
| 105 | On | Off | Off | On | Off | On | On | Off |
| 106 | Off | On | Off | On | Off | On | On | Off |
| 107 | On | On | Off | On | Off | On | On | Off |
| 108 | Off | Off | On | On | Off | On | On | Off |
| 109 | On | Off | On | On | Off | On | On | Off |
| 110 | Off | On | On | On | Off | On | On | Off |
| 111 | On | On | On | On | Off | On | On | Off |
| 112 | Off | Off | Off | Off | On | On | On | Off |
| 113 | On | Off | Off | Off | On | On | On | Off |
| 114 | Off | On | Off | Off | On | On | On | Off |
| 115 | On | On | Off | Off | On | On | On | Off |
| 116 | Off | Off | On | Off | On | On | On | Off |
| 117 | On | Off | On | Off | On | On | On | Off |
| 118 | Off | On | On | Off | On | On | On | Off |
| 119 | On | On | On | Off | On | On | On | Off |
| 120 | Off | Off | Off | On | On | On | On | Off |
| 121 | On | Off | Off | On | On | On | On | Off |
| 122 | Off | On | Off | On | On | On | On | Off |
| 123 | On | On | Off | On | On | On | On | Off |
| 124 | Off | Off | On | On | On | On | On | Off |
| 125 | On | Off | On | On | On | On | On | Off |
| 126 | Off | On | On | On | On | On | On | Off |
| 127 | On | On | On | On | On | On | On | Off |
| 128 | Off | Off | Off | Off | Off | Off | Off | On |
| 129 | On | Off | Off | Off | Off | Off | Off | On |
| 130 | Off | On | Off | Off | Off | Off | Off | On |
| 131 | On | On | Off | Off | Off | Off | Off | On |
| 132 | Off | Off | On | Off | Off | Off | Off | On |
| 133 | On | Off | On | Off | Off | Off | Off | On |
| 134 | Off | On | On | Off | Off | Off | Off | On |
| 135 | On | On | On | Off | Off | Off | Off | On |
| 136 | Off | Off | Off | On | Off | Off | Off | On |
| 137 | On | Off | Off | On | Off | Off | Off | On |
| 138 | Off | On | Off | On | Off | Off | Off | On |
| 139 | On | On | Off | On | Off | Off | Off | On |
| 140 | Off | Off | On | On | Off | Off | Off | On |
| 141 | On | Off | On | On | Off | Off | Off | On |

| Address | A0 | A1 | A2 | A3 | A4 | A5 | A6 | A7 |
|---------|-----|-----|-----|-----|-----|-----|-----|----|
| 142 | Off | On | On | On | Off | Off | Off | On |
| 143 | On | On | On | On | Off | Off | Off | On |
| 144 | Off | Off | Off | Off | On | Off | Off | On |
| 145 | On | Off | Off | Off | On | Off | Off | On |
| 146 | Off | On | Off | Off | On | Off | Off | On |
| 147 | On | On | Off | Off | On | Off | Off | On |
| 148 | Off | Off | On | Off | On | Off | Off | On |
| 149 | On | Off | On | Off | On | Off | Off | On |
| 150 | Off | On | On | Off | On | Off | Off | On |
| 151 | On | On | On | Off | On | Off | Off | On |
| 152 | Off | Off | Off | On | On | Off | Off | On |
| 153 | On | Off | Off | On | On | Off | Off | On |
| 154 | Off | On | Off | On | On | Off | Off | On |
| 155 | On | On | Off | On | On | Off | Off | On |
| 156 | Off | Off | On | On | On | Off | Off | On |
| 157 | On | Off | On | On | On | Off | Off | On |
| 158 | Off | On | On | On | On | Off | Off | On |
| 159 | On | On | On | On | On | Off | Off | On |
| 160 | Off | Off | Off | Off | Off | On | Off | On |
| 161 | On | Off | Off | Off | Off | On | Off | On |
| 162 | Off | On | Off | Off | Off | On | Off | On |
| 163 | On | On | Off | Off | Off | On | Off | On |
| 164 | Off | Off | On | Off | Off | On | Off | On |
| 165 | On | Off | On | Off | Off | On | Off | On |
| 166 | Off | On | On | Off | Off | On | Off | On |
| 167 | On | On | On | Off | Off | On | Off | On |
| 168 | Off | Off | Off | On | Off | On | Off | On |
| 169 | On | Off | Off | On | Off | On | Off | On |
| 170 | Off | On | Off | On | Off | On | Off | On |
| 171 | On | On | Off | On | Off | On | Off | On |
| 172 | Off | Off | On | On | Off | On | Off | On |
| 173 | On | Off | On | On | Off | On | Off | On |
| 174 | Off | On | On | On | Off | On | Off | On |
| 175 | On | On | On | On | Off | On | Off | On |
| 176 | Off | Off | Off | Off | On | On | Off | On |
| 177 | On | Off | Off | Off | On | On | Off | On |
| 178 | Off | On | Off | Off | On | On | Off | On |
| 179 | On | On | Off | Off | On | On | Off | On |
| 180 | Off | Off | On | Off | On | On | Off | On |
| 181 | On | Off | On | Off | On | On | Off | On |
| 182 | Off | On | On | Off | On | On | Off | On |
| 183 | On | On | On | Off | On | On | Off | On |
| 184 | Off | Off | Off | On | On | On | Off | On |
| 185 | On | Off | Off | On | On | On | Off | On |
| 186 | Off | On | Off | On | On | On | Off | On |
| 187 | On | On | Off | On | On | On | Off | On |
| 188 | Off | Off | On | On | On | On | Off | On |
| 189 | On | Off | On | On | On | On | Off | On |
| 190 | Off | On | On | On | On | On | Off | On |



| Address | A0 | A1 | A2 | A3 | A4 | A5 | A6 | A7 |
|---------|-----|-----|-----|-----|-----|-----|-----|----|
| 191 | On | On | On | On | On | On | Off | On |
| 192 | Off | Off | Off | Off | Off | Off | On | On |
| 193 | On | Off | Off | Off | Off | Off | On | On |
| 194 | Off | On | Off | Off | Off | Off | On | On |
| 195 | On | On | Off | Off | Off | Off | On | On |
| 196 | Off | Off | On | Off | Off | Off | On | On |
| 197 | On | Off | On | Off | Off | Off | On | On |
| 198 | Off | On | On | Off | Off | Off | On | On |
| 199 | On | On | On | Off | Off | Off | On | On |
| 200 | Off | Off | Off | On | Off | Off | On | On |
| 201 | On | Off | Off | On | Off | Off | On | On |
| 202 | Off | On | Off | On | Off | Off | On | On |
| 203 | On | On | Off | On | Off | Off | On | On |
| 204 | Off | Off | On | On | Off | Off | On | On |
| 205 | On | Off | On | On | Off | Off | On | On |
| 206 | Off | On | On | On | Off | Off | On | On |
| 207 | On | On | On | On | Off | Off | On | On |
| 208 | Off | Off | Off | Off | On | Off | On | On |
| 209 | On | Off | Off | Off | On | Off | On | On |
| 210 | Off | On | Off | Off | On | Off | On | On |
| 211 | On | On | Off | Off | On | Off | On | On |
| 212 | Off | Off | On | Off | On | Off | On | On |
| 213 | On | Off | On | Off | On | Off | On | On |
| 214 | Off | On | On | Off | On | Off | On | On |
| 215 | On | On | On | Off | On | Off | On | On |
| 216 | Off | Off | Off | On | On | Off | On | On |
| 217 | On | Off | Off | On | On | Off | On | On |
| 218 | Off | On | Off | On | On | Off | On | On |
| 219 | On | On | Off | On | On | Off | On | On |
| 220 | Off | Off | On | On | On | Off | On | On |
| 221 | On | Off | On | On | On | Off | On | On |
| 222 | Off | On | On | On | On | Off | On | On |
| 223 | On | On | On | On | On | Off | On | On |
| 224 | Off | Off | Off | Off | Off | On | On | On |
| 225 | On | Off | Off | Off | Off | On | On | On |
| 226 | Off | On | Off | Off | Off | On | On | On |
| 227 | On | On | Off | Off | Off | On | On | On |
| 228 | Off | Off | On | Off | Off | On | On | On |
| 229 | On | Off | On | Off | Off | On | On | On |
| 230 | Off | On | On | Off | Off | On | On | On |
| 231 | On | On | On | Off | Off | On | On | On |
| 232 | Off | Off | Off | On | Off | On | On | On |
| 233 | On | Off | Off | On | Off | On | On | On |
| 234 | Off | On | Off | On | Off | On | On | On |
| 235 | On | On | Off | On | Off | On | On | On |
| 236 | Off | Off | On | On | Off | On | On | On |
| 237 | On | Off | On | On | Off | On | On | On |
| 238 | Off | On | On | On | Off | On | On | On |
| 239 | On | On | On | On | Off | On | On | On |

| Address | A0 | A1 | A2 | A3 | A4 | A5 | A6 | A7 |
|---------|-----|-----|-----|-----|----|----|----|----|
| 240 | Off | Off | Off | Off | On | On | On | On |
| 241 | On | Off | Off | Off | On | On | On | On |
| 242 | Off | On | Off | Off | On | On | On | On |
| 243 | On | On | Off | Off | On | On | On | On |
| 244 | Off | Off | On | Off | On | On | On | On |
| 245 | On | Off | On | Off | On | On | On | On |
| 246 | Off | On | On | Off | On | On | On | On |
| 247 | On | On | On | Off | On | On | On | On |
| 248 | Off | Off | Off | On | On | On | On | On |
| 249 | On | Off | Off | On | On | On | On | On |
| 250 | Off | On | Off | On | On | On | On | On |
| 251 | On | On | Off | On | On | On | On | On |
| 252 | Off | Off | On | On | On | On | On | On |
| 253 | On | Off | On | On | On | On | On | On |
| 254 | Off | On | On | On | On | On | On | On |
| 255 | On | On | On | On | On | On | On | On |

Appendix D. Reference

Appendix D.1. Specifications



| | ProtoNode FPC-N34 | ProtoNode FPC-N35 |
|---|--|--|
| Electrical Connections | One 6-pin Phoenix connector with: RS-485 port (+ / - / gnd) Power port (+ / - / Frame-gnd) One 3-pin Phoenix connector with: RS-485 port (+ / - / gnd) One Ethernet 10/100 BaseT port | One 6-pin Phoenix connector with: RS-485 port (+ / - / gnd) Power port (+ / - / Frame-gnd) One Ethernet 10/100 BaseT port One FTT-10 LonWorks port |
| Approvals | CE Certified; TUV approved to UL 916, EN 60950-1, EN 50491-3 and CSA C22-2 standards; FCC Class A Part 15; DNP3 Conformance Tested; RoHS Compliant; CSA 205 Approved | |
| | BTL Marked | LonMark Certified |
| Power Requirements | Multi-mode power adapter: 9-30VDC or 12 - 24VAC | |
| Physical Dimensions | 11.5 cm L x 8.3 cm W x 4.1 cm H (4.5 x 3.2 x 1.6 in.) | |
| Weight | 0.2 kg (0.4 lbs) | |
| Operating Temperature | -40°C to 75°C (-40°F to 167°F) | |
| Surge Suppression | EN61000-4-2 ESD EN61000-4-3 EMC EN61000-4-4 EFT | |
| Humidity | 5 - 90% RH (non-condensing) | |
| (Specifications subject to change without notice) | | |
| Figure 38: Specifications | | |

Appendix D.1.1. Compliance with UL Regulations

For UL compliance, the following instructions must be met when operating ProtoNode.

- The units shall be powered by listed LPS or Class 2 power supply suited to the expected operating temperature range.
- The interconnecting power connector and power cable shall:
 - Comply with local electrical code
 - Be suited to the expected operating temperature range
 - Meet the current and voltage rating for ProtoNode/Net
- Furthermore, the interconnecting power cable shall:
 - Be of length not exceeding 3.05m (118.3")
 - Be constructed of materials rated VW-1, FT-1 or better
- If the unit is to be installed in an operating environment with a temperature above 65 °C, it should be installed in a Restricted Access Area requiring a key or a special tool to gain access.
- This device must not be connected to a LAN segment with outdoor wiring.



Appendix E. Limited 2 Year Warranty

Sierra Monitor Corporation warrants its products to be free from defects in workmanship or material under normal use and service for two years after date of shipment. Sierra Monitor Corporation will repair or replace any equipment found to be defective during the warranty period. Final determination of the nature and responsibility for defective or damaged equipment will be made by Sierra Monitor Corporation personnel.

All warranties hereunder are contingent upon proper use in the application for which the product was intended and do not cover products which have been modified or repaired without Sierra Monitor Corporation's approval or which have been subjected to accident, improper maintenance, installation or application, or on which original identification marks have been removed or altered. This Limited Warranty also will not apply to interconnecting cables or wires, consumables or to any damage resulting from battery leakage.

In all cases Sierra Monitor Corporation's responsibility and liability under this warranty shall be limited to the cost of the equipment. The purchaser must obtain shipping instructions for the prepaid return of any item under this warranty provision and compliance with such instruction shall be a condition of this warranty.

Except for the express warranty stated above, Sierra Monitor Corporation disclaims all warranties with regard to the products sold hereunder including all implied warranties of merchantability and fitness and the express warranties stated herein are in lieu of all obligations or liabilities on the part of Sierra Monitor Corporation for damages including, but not limited to, consequential damages arising out of/or in connection with the use or performance of the product.