



# FTVN150 & FTVN199 High Efficiency Gas-Fired Condensing Boiler

**SUBMITTAL SHEET**  
Section 1 – General Specifications  
Section 2 – Product Dimensions  
Section 3 – Field Wiring

Project Name: \_\_\_\_\_ Date: \_\_\_\_\_  
Location: \_\_\_\_\_  
Engineer: \_\_\_\_\_  
Contractor: \_\_\_\_\_ Rep: \_\_\_\_\_

## 1 – GENERAL SPECIFICATIONS

### Product Features:

- ✓ Certified to ANSI Z21.13 / CSA 4.9 Gas-fired Boiler Standard
- ✓ SA-240 S43932 Chromium Stainless Steel Fire Tube Heat Exchanger
- ✓ ASME "H" stamped boiler, designed and constructed in compliance with the ASME Boiler and Pressure Vessel Code Section IV
- ✓ Maximum operating pressure 50 psi
- ✓ Wall mounted
- ✓ Zero clearance to combustibles (clearances required for service)
- ✓ Modulating burner, 10:1 turndown ratio
- ✓ Certified as Direct Vent (sealed combustion) or for use with indoor combustion air
- ✓ Sealed cabinet
- ✓ High energy ignition transformer (spark ignition)
- ✓ Built-in water pressure bypass (guarantees minimum water flow)
- ✓ Low water pressure switch
- ✓ Integrated ECM boiler circulator
- ✓ Integrated 3-way valve (diverts between DHW & CH demands)
- ✓ Integrated Condensate Trap
- ✓ On / Off button
- ✓ Two 120 VAC outputs for external circulators (DHW/CH)
- ✓ DHW zone input (tank thermostat or sensor)
- ✓ CH zone input x 2 (ON/OFF switch or NTI Room Sensor)
- ✓ WiFi remote connectivity embedded
- ✓ Outdoor temperature sensor input (or access weather via WiFi connection)

### Control Features:

- ✓ Integral microprocessor safety control – flame safeguard and temperature
- ✓ TEST Mode – for combustion setup
- ✓ PURGE cycle – for air purging
- ✓ AUTO function (outdoor/indoor reset) – resets boiler temperature depending on outdoor and/or room temperature
- ✓ Adjustable reset curve (slope/parallel shift)
- ✓ Adjustable reset temperature boost
- ✓ Summer/Winter changeover (WWSD)
- ✓ Integrated programmable T-stat x 2 (with optional NTI Room Sensors)
- ✓ Freeze protection
- ✓ Factory settings restore option
- ✓ Cascade up to 8 FTVN-series boilers
- ✓ Adjustable ignition delay timer
- ✓ Manual mode operation (pump/fan/diverter)
- ✓ Boiler statistics
- ✓ Lockout and error history
- ✓ Optional 0-10V / 4-20mA input clip-in module
- ✓ Optional NTI 3-Zone Pump/Valve Controller
- ✓ Optional NTI Room Sensor

### Factory Supplied Items:

- ✓ 10K thermistor outdoor sensor
- ✓ 30 psi ASME pressure relief valve
- ✓ Pressure & temperature gauge
- ✓ LP conversion kit
- ✓ Vent screens

Model	CH – Water Connections, NPT	IWH – Water Connection, NPT	Gas Connection, NPT	Vent Connection	Max. Vent Length	
					2 in. pipe	3 in. pipe
FTVN150 FTVN199	1-1/4" (Male)	3/4" (Male)	3/4" (Male)	3 in. PVC/CPVC/PP	100 ft	150 ft

## Performance Specifications

Model	Input Rating, MBH	Heating Capacity, MBH	Net AHRI Rating, Water MBH	AFUE %
FTVN150	15 - 150	138	120	95
FTVN199	19.9 - 199	184	160	95



NTI Boilers Inc.

NTI Boilers Inc. 30 Stonegate Drive, Saint John, NB E2H 0A4 Canada  
Technical Services: 1-800-688-2575 Fax: 1-506-432-1135 Web: [http:// www.ntiboilers.com](http://www.ntiboilers.com)  
NTI Boilers Inc. reserves the right to change these specifications without notice



# FTVN150 & FTVN199 High Efficiency Gas-Fired Condensing Boiler

**SUBMITTAL SHEET**  
Section 1 – General Specifications  
Section 2 – Product Dimensions  
Section 3 – Field Wiring

## 2 – PRODUCT DIMENSIONS - in.

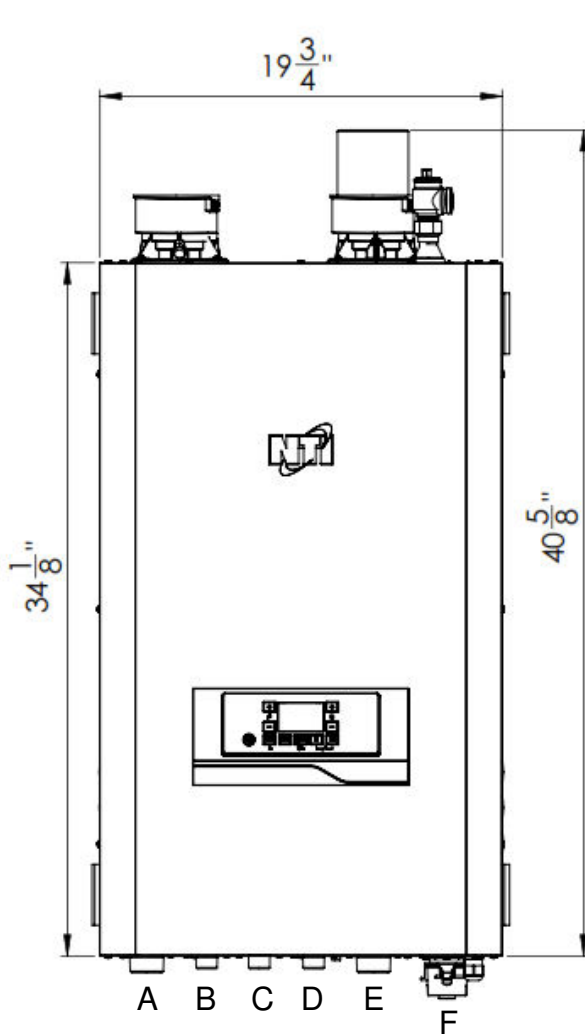

- A – Central Heating Supply
- B – Indirect Water Heater Supply
- C – Gas Inlet
- D – NA
- E – CH / IWH Return
- F – Condensate Drain

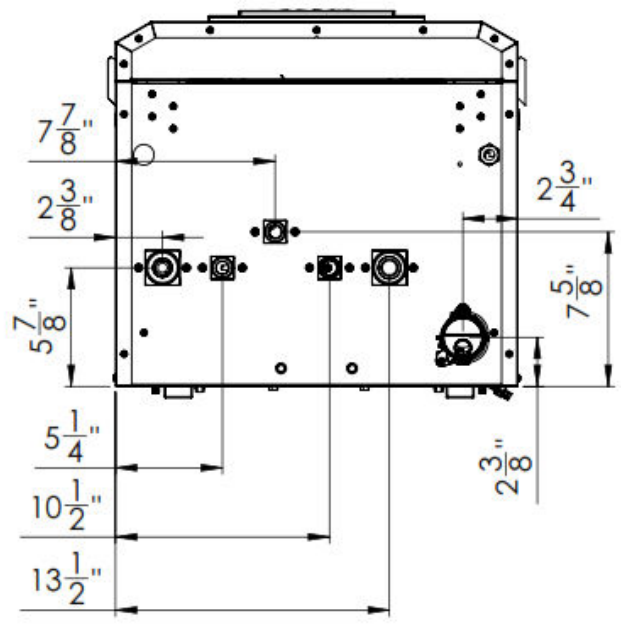
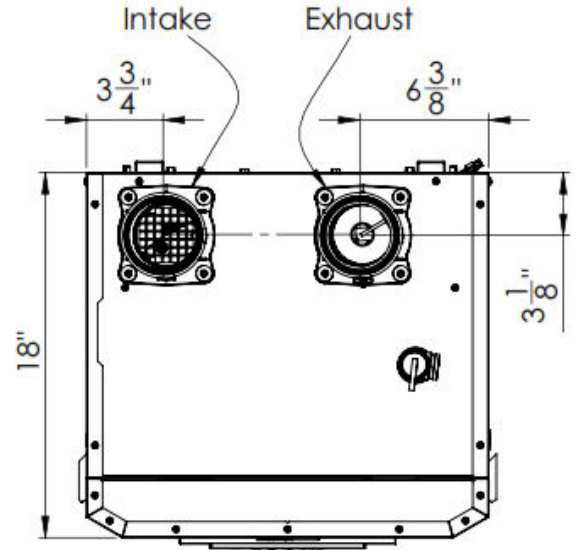

## MINIMUM SERVICE CLEARANCES - in.

Front	Top	Sides	Back	Bottom	Flue Pipe
18	14	2	0	12	1



NTI Boilers Inc.

NTI Boilers Inc. 30 Stonegate Drive, Saint John, NB E2H 0A4 Canada  
 Technical Services: 1-800-688-2575 Fax: 1-506-432-1135 Web: [http:// www.ntiboilers.com](http://www.ntiboilers.com)  
 NTI Boilers Inc. reserves the right to change these specifications without notice



FTVN150 & FTVN199  
High Efficiency Gas-Fired Condensing Boiler

SUBMITTAL SHEET  
Section 1 – General Specifications  
Section 2 – Product Dimensions  
Section 3 – Field Wiring

3 -- FIELD WIRING

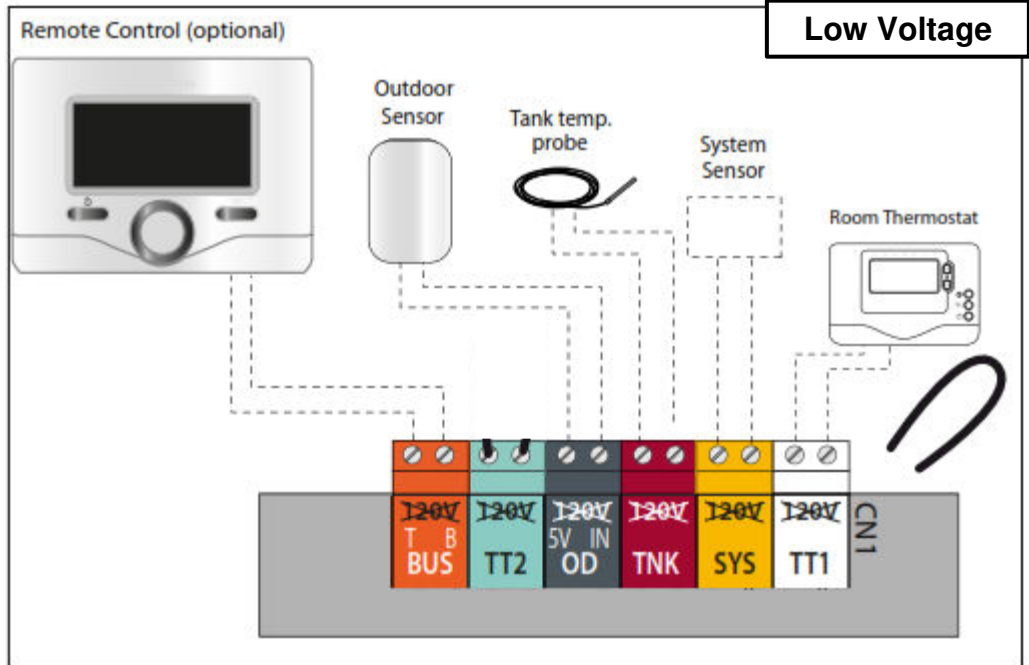
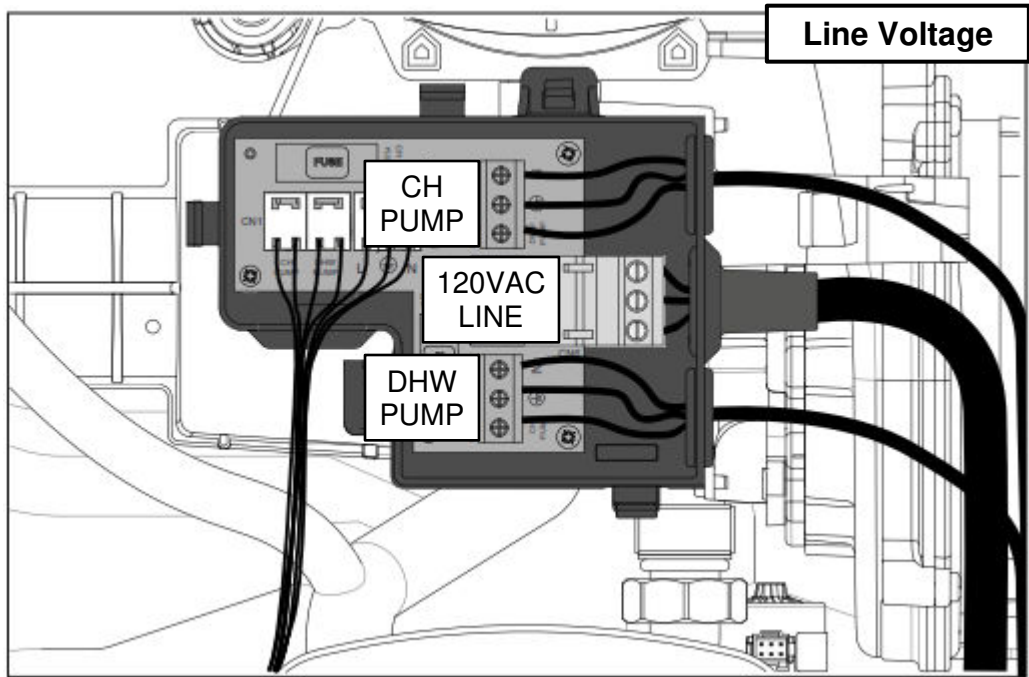

NTI Boilers Inc.

NTI Boilers Inc. 30 Stonegate Drive, Saint John, NB E2H 0A4 Canada  
Technical Services: 1-800-688-2575 Fax: 1-506-432-1135 Web: [http:// www.ntiboilers.com](http://www.ntiboilers.com)  
NTI Boilers Inc. reserves the right to change these specifications without notice