

THERM Tankless Water Heaters

Applications Manual



BOSCH

Table of Contents

1 Introduction	4
2 Bosch THERM Model Certifications	4
3 Tankless Water Heater Accessories	5
4 Water Quality	6
5 Pump Sizing	7
5.1 Pressure drop curves	7
5.2 Domestic hot water circulation	8
5.3 Tank loading	8
6 Water Heater Sizing & Specifications	9
6.1 Sizing tankless water heaters	9
6.2 Bosch tankless water heater specifications	11
7 Outdoor Installation	13
8 Domestic Water Heating Applications	14
8.1 Low volume applications	15
8.2 Whole house applications	16
9 High Volume Potable Water Heating	20
9.1 Cascading unit applications	20
9.2 Parallel unit applications	23
10 Residential Solar Applications	24
10.1 Tankloading	24
10.2 Booster applications	25
11 Commercial Solar Applications	27
12 Commercial Water Heating Applications	28
12.1 Commercial kitchen applications	28
12.2 Basic tank loading with domestic recirculation	30
12.3 Advanced tank loading commercial hot water system	31

1 Introduction

This Applications Manual is intended to present some of the most common applications of the Bosch Therm tankless water heaters. Application drawings are shown with both piping and corresponding electrical schematics where applicable. Auxiliary equipment depicted does not necessarily represent any one manufacturer or specific model number. There are a wide variety of techniques, practices and piping strategies possible when installing water heating appliances. It is the responsibility of the installing contractor to determine the most suitable arrangement for the application.

i All drawings are conceptual in nature and does not address all design, installation or safety considerations. Additional safety and/or auxiliary equipment may be needed. Drawings are for reference use by officials, designers and licensed installers. It is expected that installers have adequate knowledge of accepted industry practices for the equipment, procedures, and applications involved. It is the responsibility of the installer to ensure that the installation is in accordance with local building codes.

Although this manual covers many common applications for our products, system possibilities are virtually endless. Should you encounter an application that is not covered in this manual or have any questions regarding any of its content, we encourage you to contact your local sales representative or us directly at Bosch Thermotechnology .

This manual is not a substitute for any of the product's installation manuals. All specifications subject to change.

i Installation must conform with local codes or, in the absence of local codes, the National Fuel Gas Code ANSI Z223.1/NFPA 54.
In Canada: Installation must conform with CGA B149.(1,2) INSTALLATION CODES and/or local installation codes.

2 Bosch THERM Model Certifications

The following are certification stamps and explanations that are specific to one or more Bosch tankless water heaters. These certifications bring the appliances in accordance with the requirements of the National Fuel Gas Code ANSI Z223.1/NFPA 54.



Certified to applicable U.S. standards for appliances using gas or other petroleum fuel.



Certified to applicable Canadian standards for appliances using gas or other petroleum fuel.



Certified by Underwriters Laboratories Inc.



Energy efficiency certified by Gas Appliance Manufacturers Association (GAMA), www.gamanet.org



For Models GWH C 920 ESC and C 1210 ESC only. These models are built in accordance with the requirements of the ASME Boiler and Pressure Vessel Code and received the Certificate of Authorization from the National Board. The heat exchanger has the NB and the HLW stamps.



Plumbing-Heating-Cooling Contractors Association

Other certifications:

- ▶ Met the California Energy Commission (CEC) standards
- ▶ Approved by the Commonwealth of Massachusetts
- ▶ South Coast Air Quality Management

3 Tankless Water Heater Accessories

Available accessories					Table 1	
	C 1210 ES/ C 1210 ESC	C 1050 ES	940 ESO	940 ES	830 ES	
Concentric Vent/air Intake kit - stainless steel (part# ESHCK)				√	√	
Concentric termination kit - PVC (part# 196016)	√	√				
Exhaust / intake bird screen (part# L2594)	√	√		√	√	
Vertical vent kit (part# ESVVT)				√	√	
Horizontal vent kit (part# 4TWHVK3SII)				√	√	
Outdoor kit (part# BTOK)	√	√		√	√	
Wireless remote control (part# TSTAT2)	√	√	√	√	√	
Cascading kit (part# 77090003962)	√	√	√	√	√	
External water filter (part# 8703305356)	√	√	√	√	√	
Gas conversion kit (part# 8719002176)	√	√	√	√	√	
Pipe cover (part# PTPCES)	√	√		√	√	
High temp kit (part# 7736500074)		√	√	√	√	
Recess box kit (part# 7736500043)	√	√	√	√	√	
Pressure relief valve (part# FWL-2)	√	√	√	√	√	
PVC Condensate drain tee (part# 196061)*	√	√				
Condensate neutralization cartridge kit (part# JM-2KIT)	√	√				

* Also included in the Concentric termination kit (part# 196016)

Available accessories continued					Table 2
	660 EF	660 EFO	520 HN	520 PN	330 PN
Pipe cover (part# BPCKIT)	√	√			
Remote control - for U.S.A (part# BRC01US)	√	√			
Remote control - for Canada (part# BRC01CA)	√	√			
Remote controller outdoor junction box (part# BOJB)	√	√			
Remote controller cord 10ft (3m) (part# BRC10CORD)	√	√			
Remote controller cord 26ft (8m) (part# BRC26CORD)	√	√			
Isolation valves - pressure relief valve included (part# 9260LA)	√	√			
Pressure relief valve (part# FWL2)	√	√	√	√	√
Freeze prevention kit (part# (7709003775)			√	√	

4 Water Quality

Poor water quality will have an impact on appliance longevity and may void the manufacturer's warranty. For water analysis data call your local water department, or if on a well, have well water analyzed periodically. If water quality exceeds one or more of the values specified below, Bosch recommends consulting a local water treatment professional for water softening/conditioning options.

Water quality max. levels		Table 3
Description	Max. Levels	
pH	pH	6.5 - 8.5
TDS (Total Dissolved Solids)	mg/l or ppm	500
Total hardness	mg/l or ppm	100 (6 grains)
Aluminum	mg/l or ppm	2.0
Chlorides	mg/l or ppm	250
Copper	mg/l or ppm	1.0
Iron	mg/l or ppm	0.3
Manganese	mg/l or ppm	0.05
Zinc	mg/l or ppm	5.0

5 Pump sizing

The following section outlines sizing pumps for domestic hot water circulation and tank loading. Only models approved for such applications are listed in this section.

- ▶ Pump must be bronze or stainless steel.
- ▶ Size the pump according to the system pressure drop chart below.
- ▶ Maximum flow allowed through the recirc loop is 5 GPM.

i If the water heater is used within an approved hot water recirculation application and supplied with circulated water, the heat exchanger warranty is decreased. Please refer to the installation manual for detailed warranty period information.

i Run the system for 30 minutes to remove debris from the plumbing. Then remove the unit's inlet water filter to decrease pressure drop through the system. If the inlet water filter, when removed, contains debris install a Y-strainer (installer supplied) on the cold water inlet.

5.1 Pressure drop curves

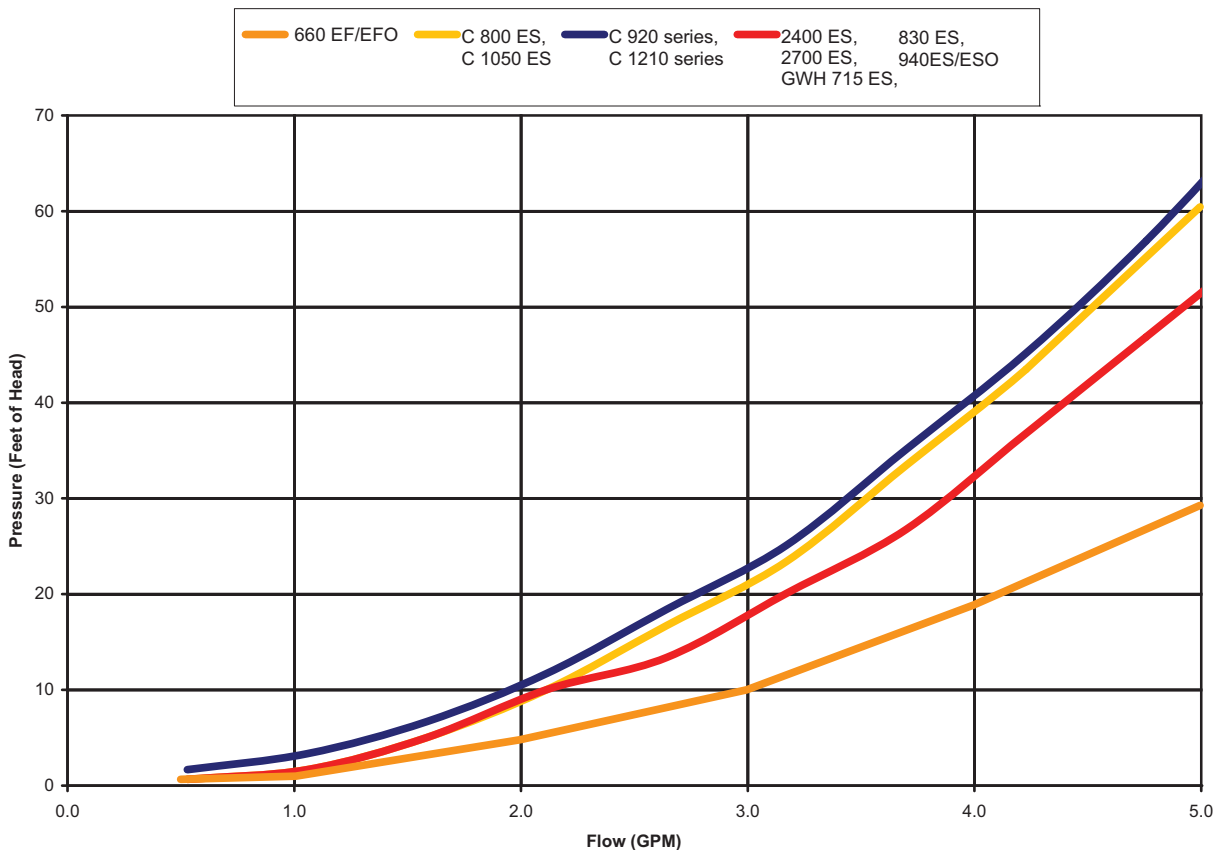

5.2 Domestic hot water circulation

► **Must provide a recirculation flow above 1.7 GPM.** This can be verified in the control unit diagnostics section of the installation manual; mode P4 – 3d.

► **Note:** The Grundfos model 15-55 has been tested and shown to work on recirculating systems up to 120 feet of total pipe length. System conditions vary and each pump must be sized by a professional to insure performance.

Refer to pump manufacturers flow vs pressure specifications to select a pump that can provide the flow rate greater than 1.7 gpm while overcoming the pressure loss through:

- Tankless water heater (see Chapter 6.1)
- All building supply and return plumbing in the circulation loop (reference local plumbing codes, standards, or practices)

System pressure drop	
	Pressure drop ¾" copper (PSI)
90 degree elbow	0.088
45 degree elbow	0.053
10 ft of straight pipe ½"	1.3
10 ft of straight pipe ¾"	0.35

Source: International Plumbing Code 2003 edition.

Examples:

- 1) Average house (less than 2500 square feet)
 - a) Total loop length approximately 120 ft
 - b) Pump recommendation: Grundfos UP 15-55 or equivalent.
- 2) Large house (2500 to 5000 square feet)
 - a) Total loop length approximately 240 ft
 - b) Pump recommendation: Grundfos UP 25-64 or equivalent.

NOTE: Use only bronze or stainless steel pumps. Do not use pumps of iron construction as they will oxidize and clog the inlet filter on the appliance.

Recommendations for domestic hot water recirculation

- An Aquastat, with a 5° F differential to control the pump, is recommended.
- The usage of a timer is recommended to limit the energy consumption. The timer should also limit recirculation pump operation to the time of day when occupants are home and likely to use hot water.
- Water heater set point must be minimum of 14° F above the Aquastat setpoint.
Example: Tankless water heater setpoint = 122°F
Aquastat setpoint = 108°F
- Keep hot water piping insulated to limit heat loss.
- Set temperature on the C 1210 ESC must not exceed 140°F.

5.3 Tank loading

Pressure drop vs. flow		
# of units	Pressure drop vs. flow Models: C1050ES, C1210ES, C1210ESC	Pressure drop vs. flow Model: 940ES/ESO
1	4gpm @ 40 feet of head	4gpm @ 32 feet of head
2	8gpm @ 40 feet of head	8gpm @ 32 feet of head
3	12gpm @ 40 feet of head	12gpm @ 32 feet of head
4	16gpm @ 40 feet of head	16gpm @ 32 feet of head

These guidelines should be followed to maximize system output:

- Ensure flow through each water heater is between 3.5-5.0 gpm
- Isolation valves or boiler drains should be installed to facilitate descaling in applications with hard water.
- Whenever possible, plumb the system or configure the tank to draw cold supply water into the water heater during hot water use.

We recommend Grundfos UP26-99, Taco 009 or equivalent potable water circulators for single unit tank loading installations.

6 Water Heater Sizing & Specifications

This section describes the water heaters available from Bosch Thermotechnology Corporation and provides a general overview to the specifications of that particular model. More detailed information is contained in the installation manuals. Download these manuals at www.BoschPro.com.

6.1 Sizing tankless water heaters

Definitions

- ▶ Major applications (2 GPM or more): Washing machine, bath tub, shower nozzle
- ▶ Minor applications(2 GPM or less): Low flow shower head, bathroom sink, kitchen sink

Rule of thumb sizing

The tables below provide a general rule of thumb when sizing for most residential applications. For commercial applications or for a more detailed sizing method, use the **Sizing by Chart** instructions below in conjunction with the charts on the next page.

Rule of Thumb Sizing		
Model Number	Number of Major Applications	Number of Minor Applications
C 1210 ES/ESC	3	1
C 1050 ES	2	1
940 ES/ESO	2	0
830 ES	1	2
660EF/EFO	1	1
520 HN/PN	1	0
330 PN	0	1

Sizing by Chart

- ▶ Measure the flow rates at each fixture that will be used simultaneously and add them together. If only one application will be used at a time measure each fixture and use the maximum flow rate observed
- ▶ Using a known volume container, record several fill times. Perform the calculation below to determine the flow rate (a one gallon fill time of 30 seconds is 2.0 gallons per minute (GPM):

$$\text{Flow rate (GPM)} = \frac{\text{Volume (gallons)}}{\text{Fill time (sec)}} \times 60 \frac{\text{sec}}{\text{min}}$$

- ▶ Using a thermometer, measure the incoming water temperature. For reference, see average ground water temperature map. Subtract this temperature from the desired hot water temperature to get the degree rise. If the desired hot water temperature is 120F and incoming temperature is 55F, the desired degree rise is 65F.

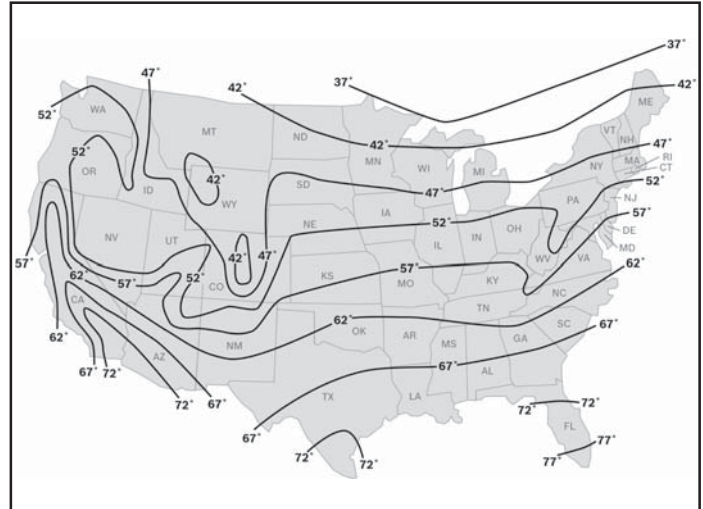
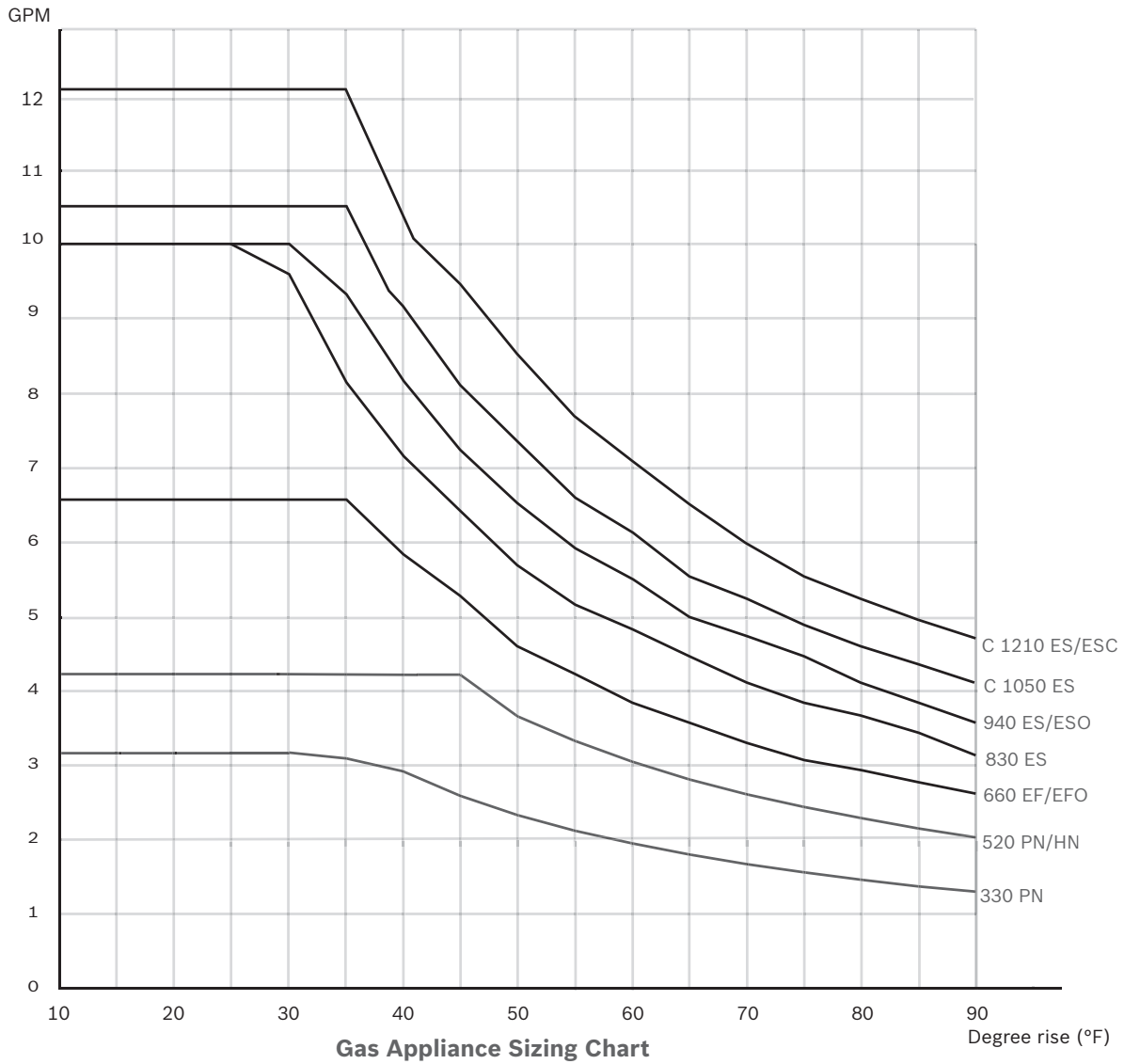

Figure 1 Average ground water temperatures

EXAMPLE:

- Required flow rate of 2.0 GPM at a 65° F rise.
- Refer to the graphs on the following page.
- Since the demand is above the 330 PN capacity, this application would require a 520 HN/PN gas tankless water heater.



- **Flows above 10 GPM assume installation of a mixing valve to help mitigate pressure drop in the water heater and plumbing system**

6.2 Bosch Tankless Water Heater Specifications

Technical Specifications					
Model	C 1210 ES/ESC	C 1050 ES	940 ES	940 ESO	830 ES
Gas input (BTU/hr)	Min: 25,000	Min: 19,900	Min: 19,900	Min: 19,900	Min: 19,900
	Max: 225,000	Max: 199,000	Max: 199,000	Max: 199,000	Max: 175,000
Minimum flow to activate (GPM)	0.5	0.5	0.5	0.5	0.5
Maximum flow rate at 35° rise (GPM)	12.1	10.5	9.4	9.4	8.3
Maximum flow rate at 90° rise (GPM)	4.6	3.9	3.6	3.6	
Thermal Efficiency	NG: 94% LP: 94%	NG: 92% LP: 92%	NG: 82% LP: 82%	NG: 82% LP: 82%	NG: 82% LP: 82%
Dimensions (inches)	H: 30½ W: 17⅝ D: 11¼	H: 30½ W: 17⅝ D: 11¼	H: 30½ W: 17⅝ D: 11¼	H: 30½ W: 17⅝ D: 11¼	H: 30½ W: 17⅝ D: 11¼
Weight (lbs.)	88	74	67	67	67
Modulating gas valve	yes	yes	yes	yes	yes
Ignition	Electronic	Electronic	Electronic	Electronic	Electronic
Gas connection	¾" Male NPT	¾" Male NPT	¾" Male NPT	¾" Male NPT	¾" Male NPT
Water connections	¾" Male NPT	¾" Male NPT	¾" Male NPT	¾" Male NPT	¾" Male NPT
NG gas pressure (inches of W.C.)	Min: 3.5 Max: 10.5	Min: 3.5 Max: 10.5	Min: 3.5 Max: 10.5	Min: 3.5 Max: 10.5	Min: 3.5 Max: 10.5
LP gas pressure (inches of W.C.)	Min: 8 Max: 13	Min: 8 Max: 13	Min: 8 Max: 13	Min: 8 Max: 13	Min: 8 Max: 13
Water pressure Static - (PSI)	Min: 30 Min (well): 40 Max: 150	Min: 30 Min (well): 40 Max: 150	Min: 30 Min (well): 40 Max: 150	Min: 30 Min (well): 40 Max: 150	Min: 30 Min (well): 40 Max: 150
Electrical supply	120VAC	120VAC	120VAC	120VAC	120VAC
Venting options	direct vent room-sealed combustion	direct vent room-sealed combustion	direct vent room-sealed combustion	BTOK outdoor kit included with heater	direct vent room-sealed combustion
Venting diameter (inches)	3 or 4	3 or 4	3 or 4	3 or 4	3 or 4
Vent material	PVC, CPVC, or ABS (Schedule 40)	PVC, CPVC, or ABS (Schedule 40)	Stainless steel (AL29-4C)	Outdoor vent cap supplied	Stainless steel (AL29-4C)

NOTE:

- C 1210 ES (residential model) has a maximum setpoint temperature of 140°F.
- C 1210 ESC (commercial model) has a maximum setpoint temperature of 180°F.

Technical Specifications continued					
Model	660 EF	660 EFO	520 HN	520 PN	330 PN
Gas input (BTU/hr)	Min: 20,000	Min: 20,000	Min: 30,735	Min: 31,000	Min:
	Max: 140,000	Max: 140,000	Max: 117,000	Max: 117,000	Max: 74,900
Minimum flow to activate (GPM)	0.5	0.5	0.5	0.5	0.5
Maximum flow rate at 35° rise (GPM)	6.6	6.6	5.2	5.2	3.3
Maximum flow rate at 90° rise (GPM)	2.6	2.6	2.0	2.0	1.3
Thermal Efficiency	NG: 82% LP: 82%	NG: 82% LP: 82%	NG: 80% LP: 80%	NG: 78% LP: 78%	NG: 78% LP: 78%
Dimensions (inches)	H: 20.5 W: 13.8 D: 6.7	H: 20.5 W: 13.8 D: 6.7	H: 36.75 W: 18.25 D: 10.5	H: 25.79 W: 18.11 D: 8.66	H: 22.83 W: 12.20 D: 8.66
Weight (lbs.)	36	36	35	35	26
Modulating gas valve	yes	yes	no	no	no
Ignition	Electronic	Electronic	Hydro-generated	Standing pilot	Standing pilot
Gas connection	¾" Male NPT	¾" Male NPT	¾" Male NPT	¾" Male NPT	½" Male NPT
Water connections	¾" Male NPT	¾" Male NPT	½" Male NPT	½" Male NPT	½" Male NPT
NG gas pressure (inches of W.C.)	Min: 4 Max: 10.5	Min: 4 Max: 10.5	Min: 5.7 Max: 14	Min: 5.7 Max: 14	Min: 5.7 Max: 14
LP gas pressure (inches of W.C.)	Min: 8 Max: 14	Min: 8 Max: 14	Min: 10.5 Max: 14	Min: 10.5 Max: 14	Min: 10.5 Max: 14
Water pressure Static - (PSI)	Min: 30 Min (well): 40 Max: 150	Min: 30 Min (well): 40 Max: 150	Min: 30 Min (well): 40 Max: 150	Min: 30 Min (well): 40 Max: 150	Min: 30 Min (well): 40 Max: 150
Electrical supply	120VAC	120VAC	N/A	N/A	N/A
Venting options	Fan assisted Vertical and horizontal termination	Outdoor installation	Vertical natural draft * horizontal termination only with AQ4 vent kit	Vertical natural draft * horizontal termination only with AQ4 vent kit	Vertical natural draft * horizontal termination not allowed
Venting diameter (inches)	3	N/A	5	5	4
Vent material	Stainless steel (AL29-4C)	N/A	Type B-vent recommended	Type B-vent recommended	Type B-vent recommended

7 Outdoor Installation

The models listed below are designed to be installed indoors. However, they are approved for outdoor installation when installed with the Outdoor Kit (part# BTOK):

- ▶ 830 ES
- ▶ 940 ES/ESO
- ▶ C 1050 ES
- ▶ C 1210 ES/ESC

Outdoor Kit (BTOK) installation:

- ▶ The installation of this outdoor kit (BTOK) is required when installing any of the above appliances outdoors.
- ▶ Outdoor cap easily retrofits to these indoor models.
- ▶ Exterior water piping should be protected if short term freezing conditions could exist.
- ▶ Not for use in areas routinely exposed to freezing temperatures.

Minimum clearances:

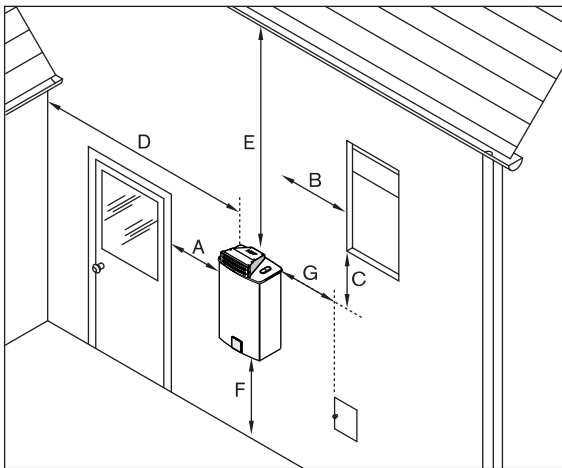

Ref.	Description	Min. distances
A	Directly below or adjacent to an opening; operable windows, doors and any fresh air openings	≥ 1 ft
B		
C		
D	From any adjacent wall	≥ 1 ft
E	Below a gutter, sanitary pipework, eaves or overhang	≥ 3 ft
F	Above ground	≥ 1 ft
G	From a gas meter or gas regulator	≥ 3 ft

Outdoor Installation Clearances

Source: NFPA 54 National Fuel Gas Code ANSI Z223.1

Installation on wood siding

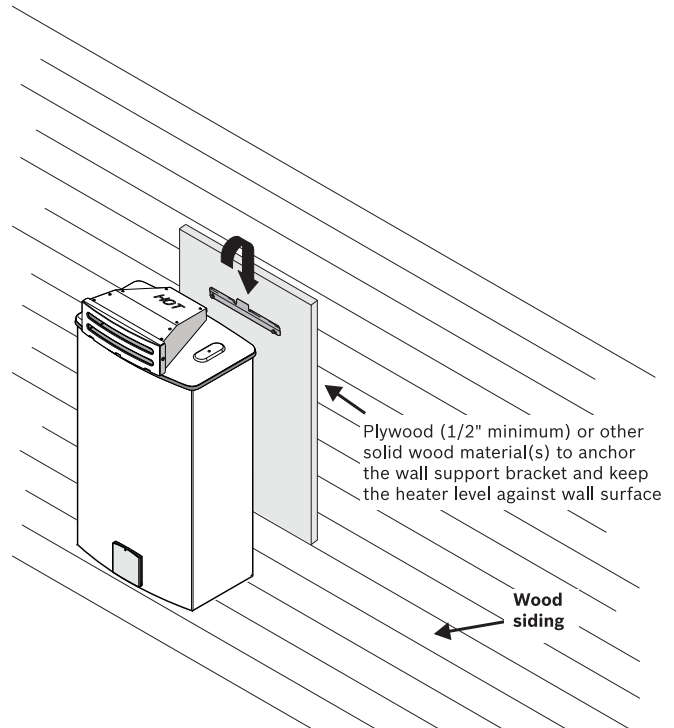

Installation on vinyl siding:

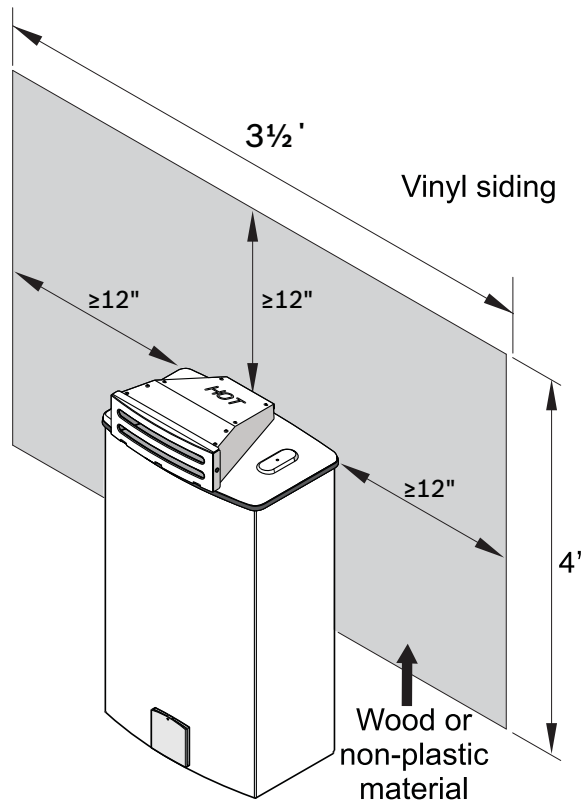

8 Domestic Water Heating Applications

Potable water

Potable water is water that is suitable for drinking. Bosch Water Heating appliances are approved to heat potable water only. Heating any other liquid other than potable water will void the manufacturer's warranty covering the appliance.

Introduction

This chapter covers the various application techniques Bosch Water Heating recommends. The schematics are to be used by professional contractors in designing a domestic water heating system. The applications covered range from single appliance low volume applications to multi-appliance central domestic recirculation applications.

8.1 Low volume applications

Low volume applications cover the small applications in which a large water heater would be inefficient. Common applications for these appliances include cottages, cabins, and summer camps. The Bosch THERM 330 PN gas tankless water heater offers a compact and lightweight design for easy installation in these applications.

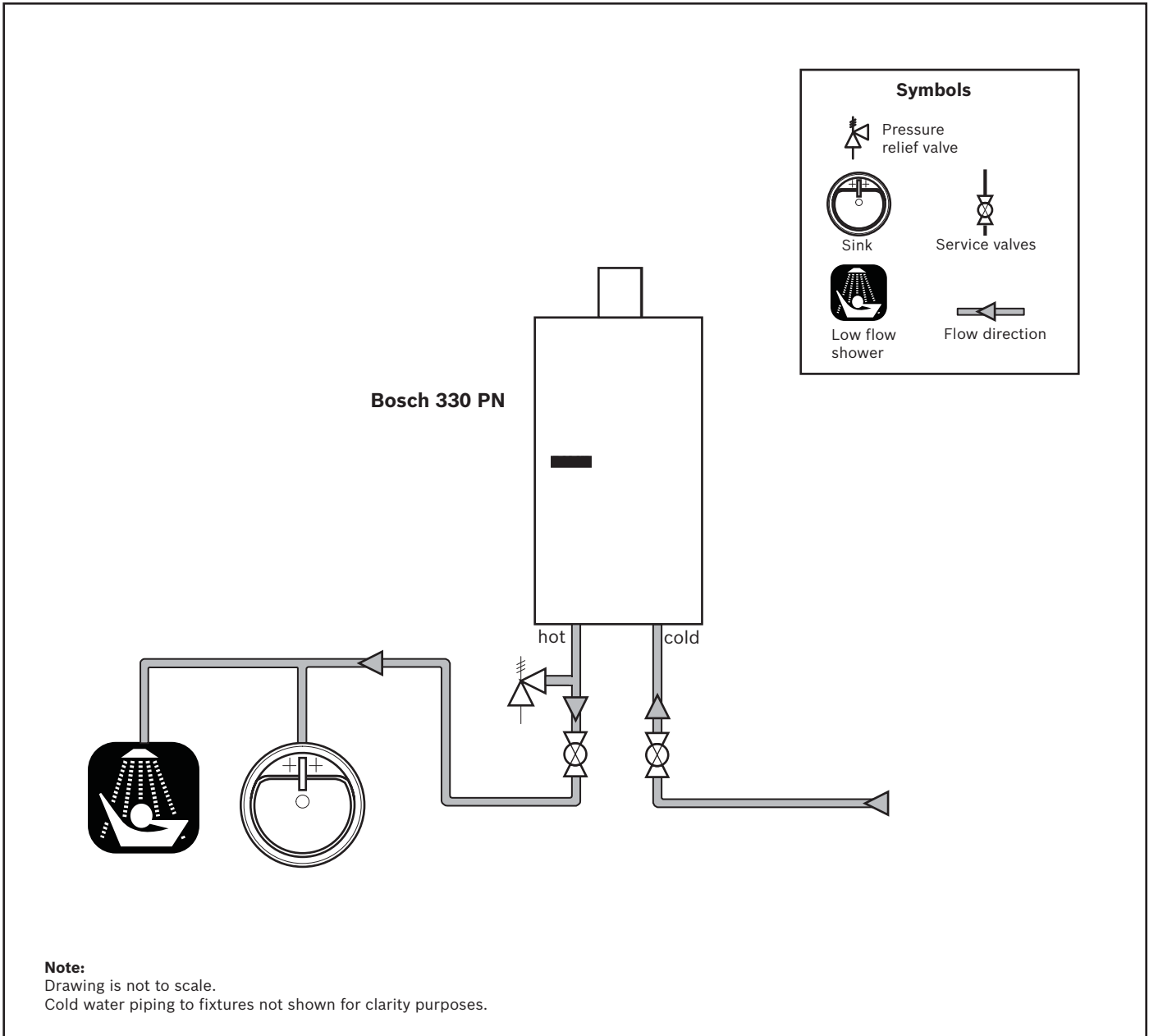

8.2 Whole house applications

Whole house applications cover the typical home applications up to a 2 or 3 bedroom house. See the sizing guide (page 9) to determine the best Bosch water heater model for your application. An enhanced design including an Ariston mini tank in line to the hot water source will reduce the wait time for hot water and improve temperature stability.

8.2.1 Bosch gas water heater

Below is an example of a basic Bosch gas tankless water heater installation for the whole house.

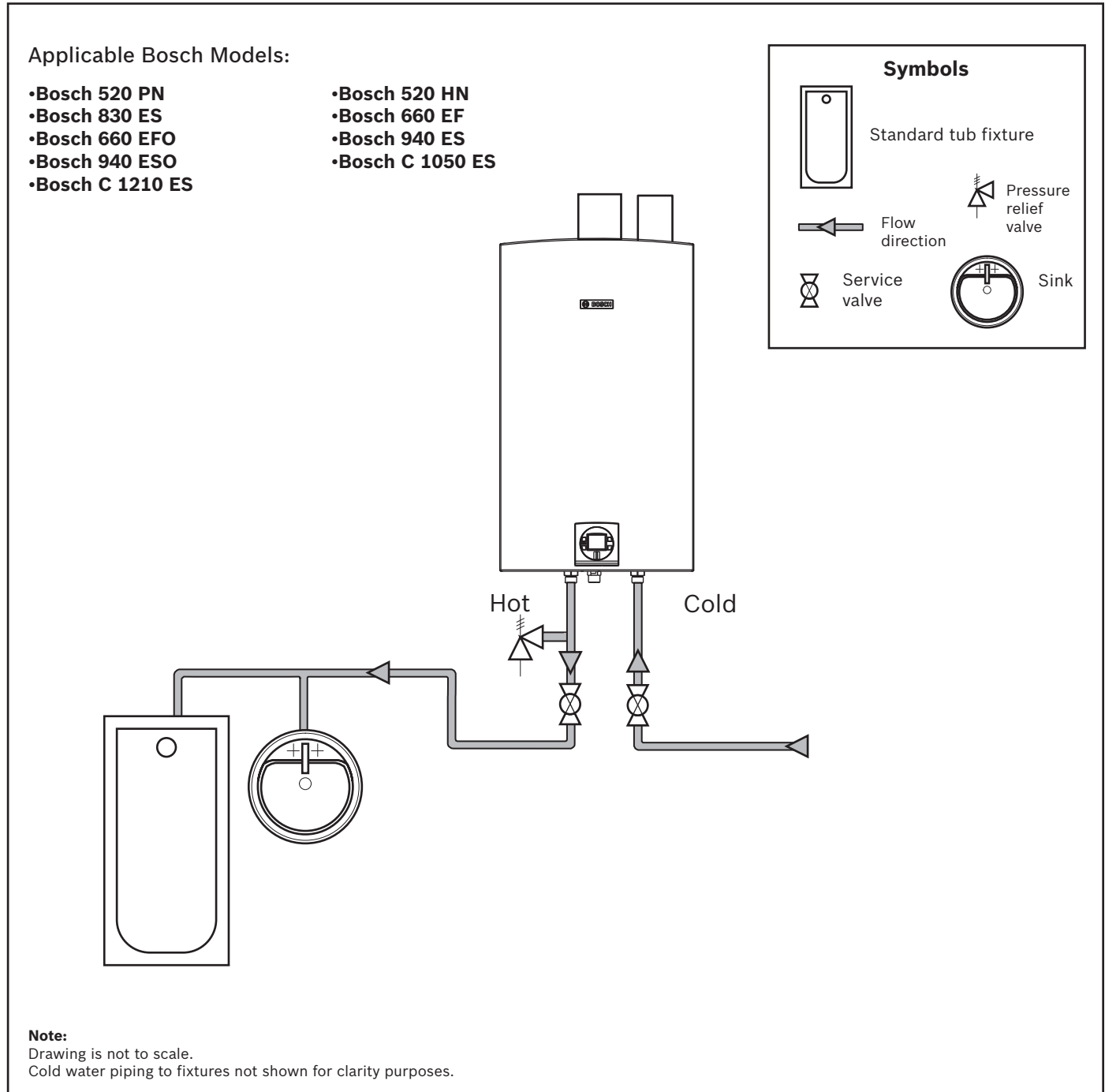

8.2.2 Bosch gas water heater with buffer tank

Below is an example of a Bosch tankless water heater installation for the whole house. An Ariston mini tank is installed in line for reduced hot water wait time and increased temperature stability.

Applicable Bosch Models:

- Bosch 520 PN
- Bosch 830 ES
- Bosch 660 EFO
- Bosch 940 ESO
- Bosch C 1210 ES
- Bosch 520 HN
- Bosch 660 EF
- Bosch 940 ES
- Bosch C 1050 ES

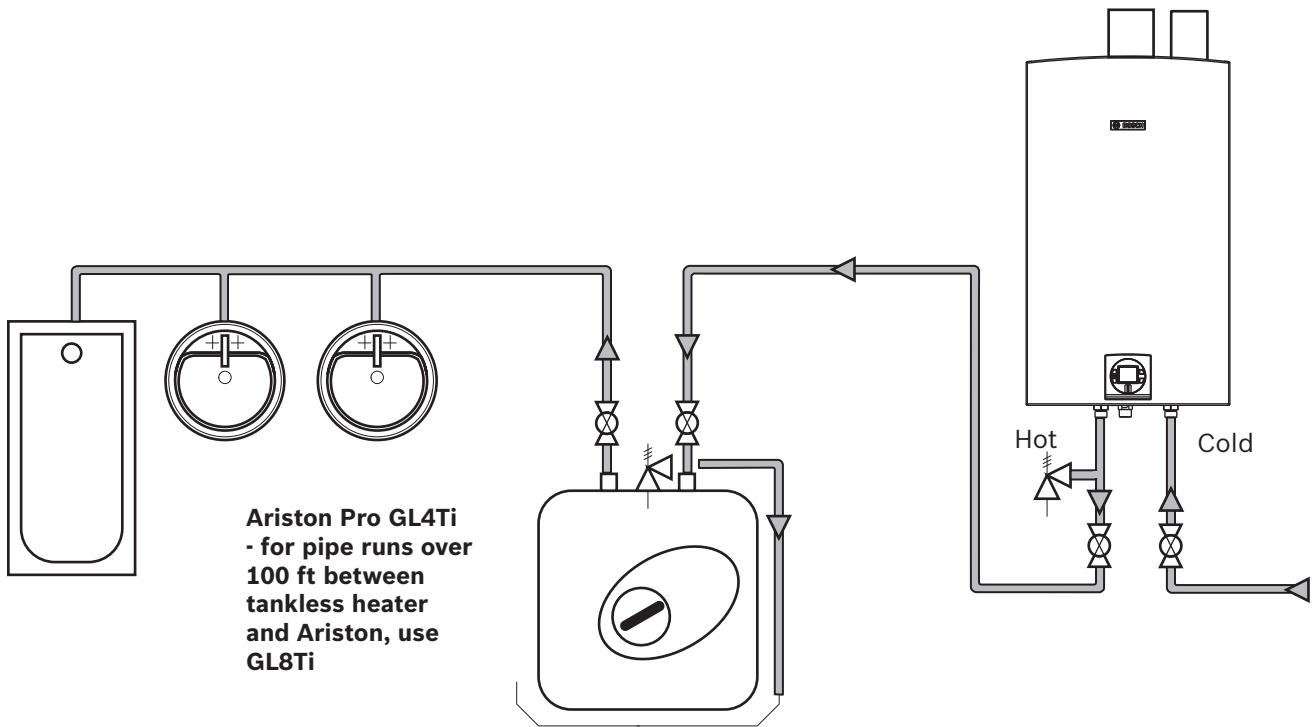
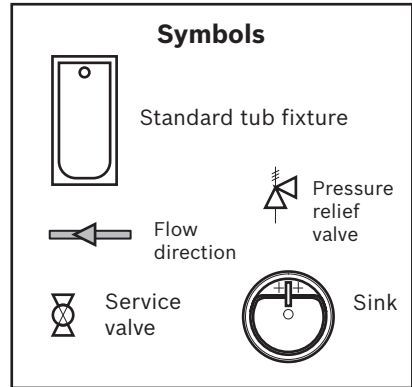

Ariston Pro GL4Ti
- for pipe runs over
100 ft between
tankless heater
and Ariston, use
GL8Ti

Note: place Ariston close to the point of use to reduce wait time for hot water.

Note:
Drawing is not to scale.
Cold water piping to fixtures not shown for clarity purposes.

8.2.3 Bosch gas water heater with domestic recirculation loop

The circulator should be controlled by an external aquastat or with a timer to run only during times of expected hot water usage. Insulate piping in hot water recirculation loop to limit heat loss.



See Chapter 5 for recirculation pump parameters

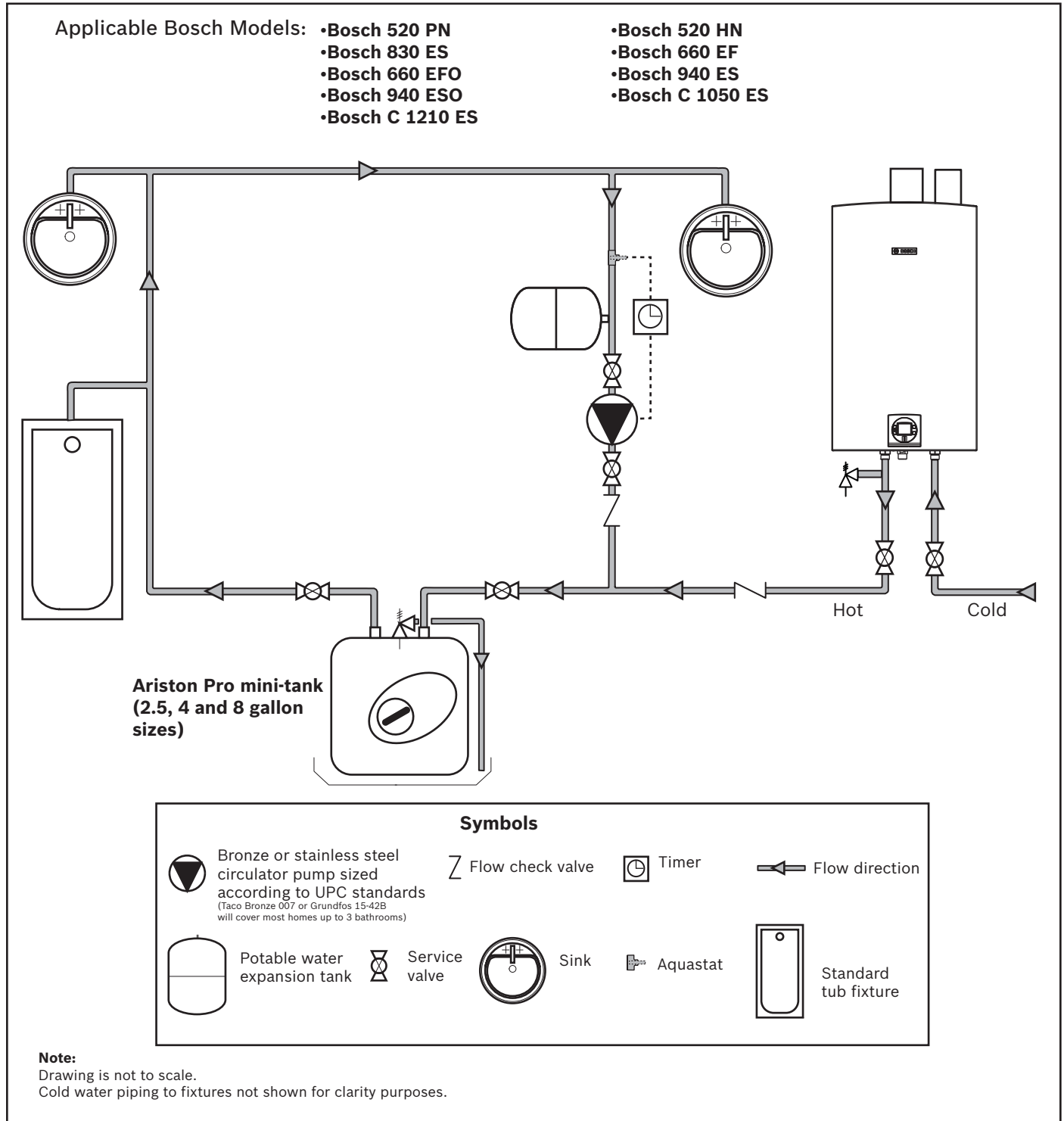

8.2.4 Bosch gas water heater with direct recirculation loop

Use a circulator, aquastat and/or timer, to keep a loop of hot water constantly hot and ready to use. This limits wait time for hot water delivery to the tap and excessive waste of water. Insulate piping in hot water recirculation loop to limit heat loss.



See Chapter 5.1 for recirculation pump parameters



If the water heater is used within an approved hot water recirculation application and supplied with circulated water, the heat exchanger warranty is decreased. Please refer to the installation manual for detailed warranty period information.

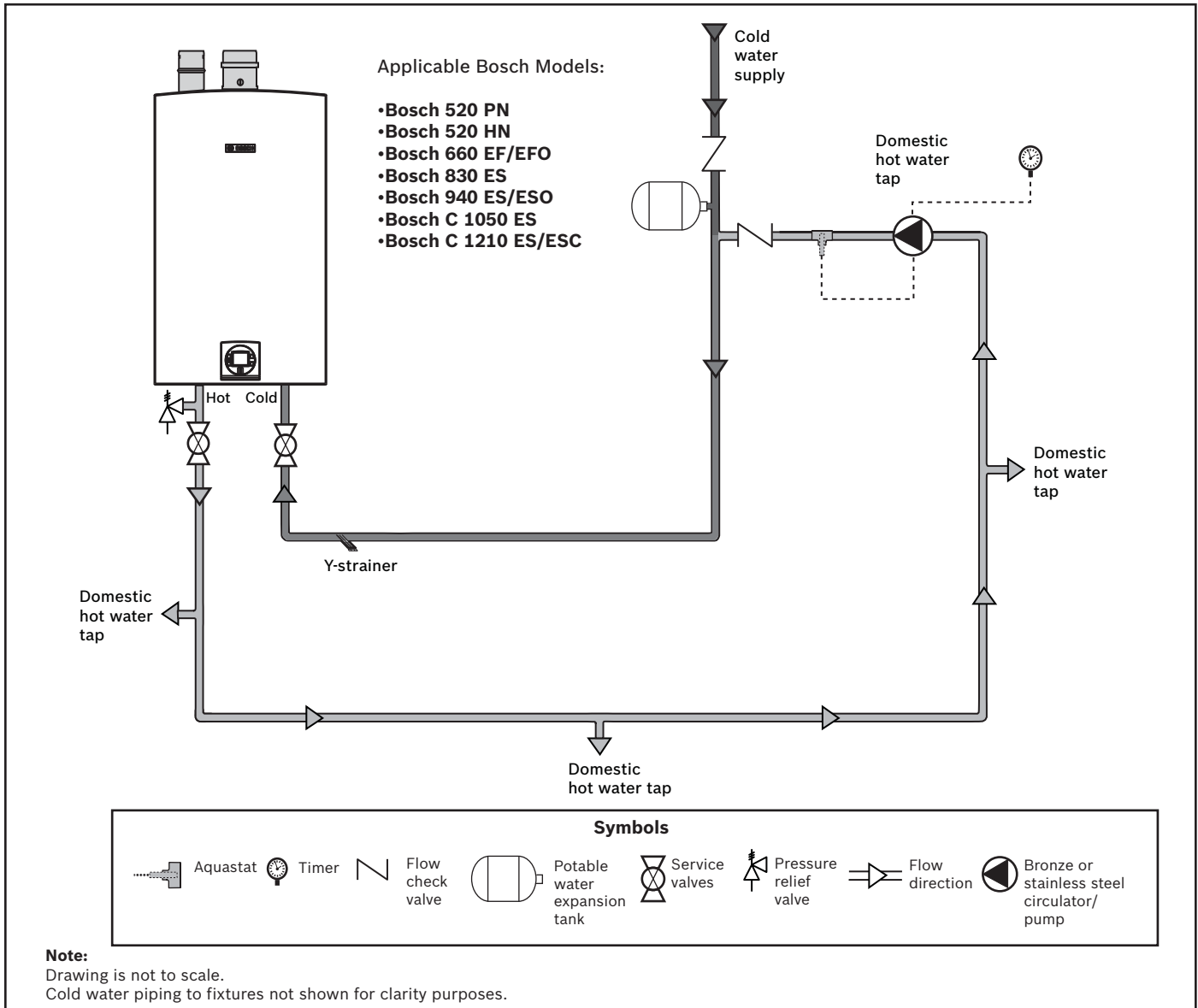

9 High Volume Potable Water Heating

Potable water

Potable water is water that is suitable for drinking. Bosch Water Heating appliances are approved to heat potable water only. Heating any other liquid other than potable water will void the manufacturer's warranty covering the appliance.

Introduction

This section lays out the options for high volume water heating for large residential and light commercial applications including continuous flows.

9.1 Cascading unit applications

A cascading application should be considered if the potential hot water demand exceeds the capacity of one gas tankless water heater. The cascading set up supports variable flow inputs and is designed for large homes and commercial applications. Cascading, unlike other parallel applications, maintains the activation flow rate of a single appliance.

Intelligent Cascading allows up to twenty four appliances to be connected in parallel. One of the appliances will serve as the controlling primary appliance and will attempt to meet the hot water demand. If the hot water demand is beyond the capacity of the primary appliance, a signal is sent to one or more of the secondary appliances to ignite.

With the Intelligent Cascading, after each 100 hours of operation, the system will automatically rotate which heater is serving as the primary.

An Intelligent Cascading Kit (part no. 7709003962) must be purchased and installed for each secondary appliance included in the installation.

Example: A 7 unit cascade installation includes 1 primary appliance and 6 secondary appliances. 6 intelligent cascading kits must be purchased for this installation.

9.1.1 830ES, 940ES/ESO, C1050ES, C1210ES/ESC intelligent cascading with domestic hot water recirculation

For applications with 200ft of pipe or more.

System parameters:

- The plumbing must be connected in the reverse return method with a minimum number of elbows to aid in balancing pressures between the appliances.
- Locate appliances close together for improved performance.
 - Maximum distance between appliances: 36”.
 - Minimum distance between appliances: 1”.
- Minimum pipe diameter: 3/4” (2 appliances or less).
- Minimum pipe diameter: 1” (3 appliances or more).
- Minimum water pressure: 50 psi.
- Insulate pipes to prevent heat loss.



See Chapter 5 for recirculation pump parameters

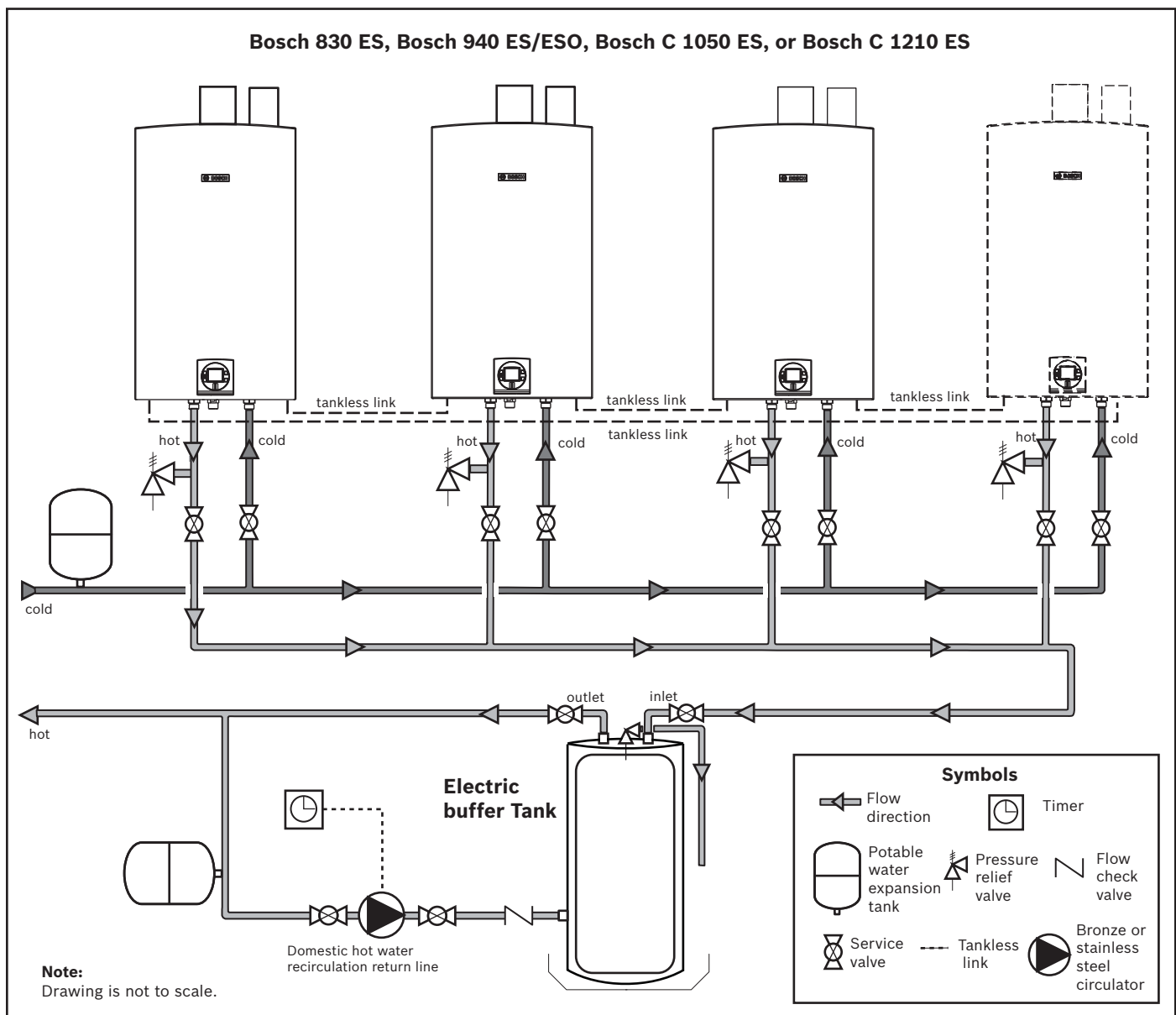

9.1.2 830ES, 940ES/ESO, C1050ES, C1210ES/ESC intelligent cascading with domestic hot water recirculation

For applications with 200ft of pipe or less.

System parameters:

- The plumbing must be connected in the reverse return method with a minimum number of elbows to aid in balancing pressures between the appliances.
- Locate appliances close together for improved performance.
 - Maximum distance between appliances: 36".
 - Minimum distance between appliances: 1".
- Minimum pipe diameter: 3/4" (2 appliances or less).
- Minimum pipe diameter: 1" (3 appliances or more).
- Minimum water pressure: 50 psi.
- Insulate pipes to prevent heat loss.



See Chapter 5.1 for recirculation pump parameters

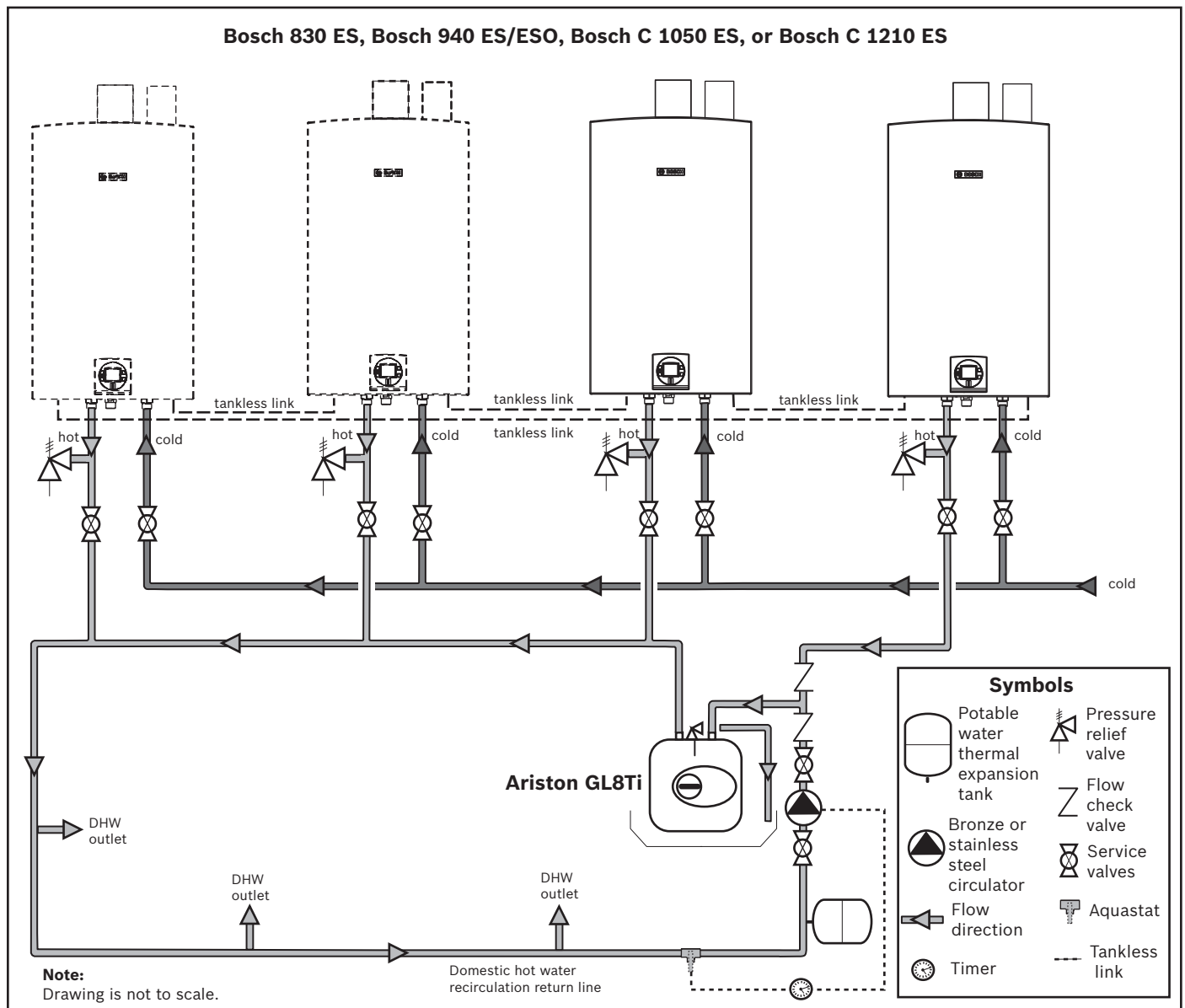

9.2 Parallel unit applications

Two Bosch water heaters plumbed in parallel will have double the flow rate. However, the activation rate increases with each unit added in parallel.

Example:

- 1 unit - 0.5 GPM activation rate
- 2 units - 1.0 GPM activation rate
- 3 units - 1.5 GPM activation rate

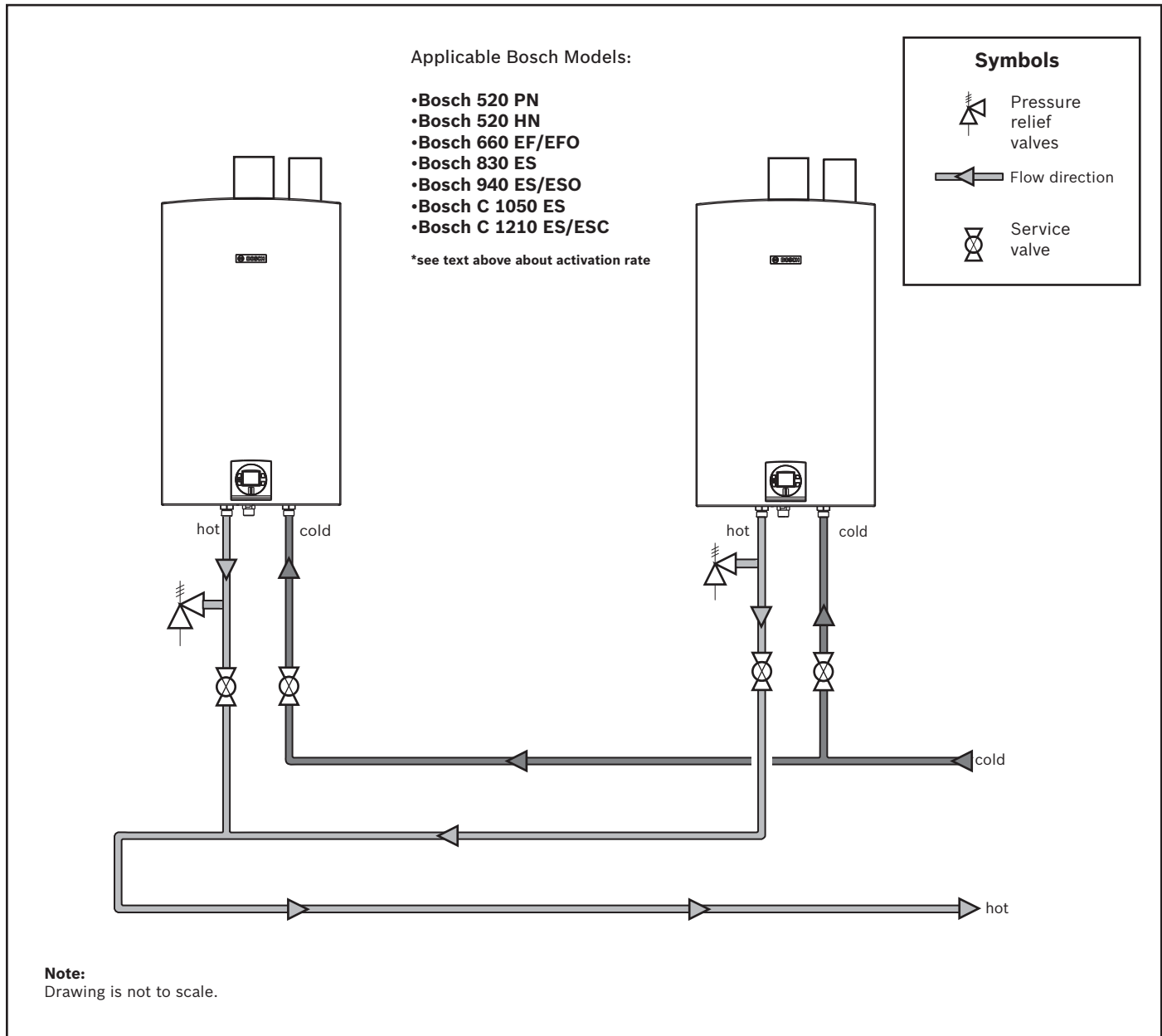

10 Residential Solar Applications

Introduction

This section gives a general overview of tank loading and in line booster applications for domestic hot water in conjunction with solar water heating. For additional system details, consult the Bosch Solar Technical Guide

10.1 Tank loading

10.1.1 Solar DHW system with gas tankless water heater tank loading

In this system the gas tankless water heater keeps the comfort zone at top of tank at desired temperature.

- ▶ Use applicable models with aquastat that activates circulator.
- ▶ Timer recommended to interrupt reheating during night time.

Aquastat / Water Heater setpoints		
Model Number	Aquastat setpoint	Water heater setpoint
C 1210 ESC	≤140°F	14°F above Aquastat setpoint
830 ES, 940 ES/ESO, C 1050 ES, C 1210 ES	≤126°F*	140°F

* If local codes require higher setpoint or to increase the recovery capacity of the water heater, contact Bosch Thermotechnology.



See Chapter 5.2 for tank loading pump parameters

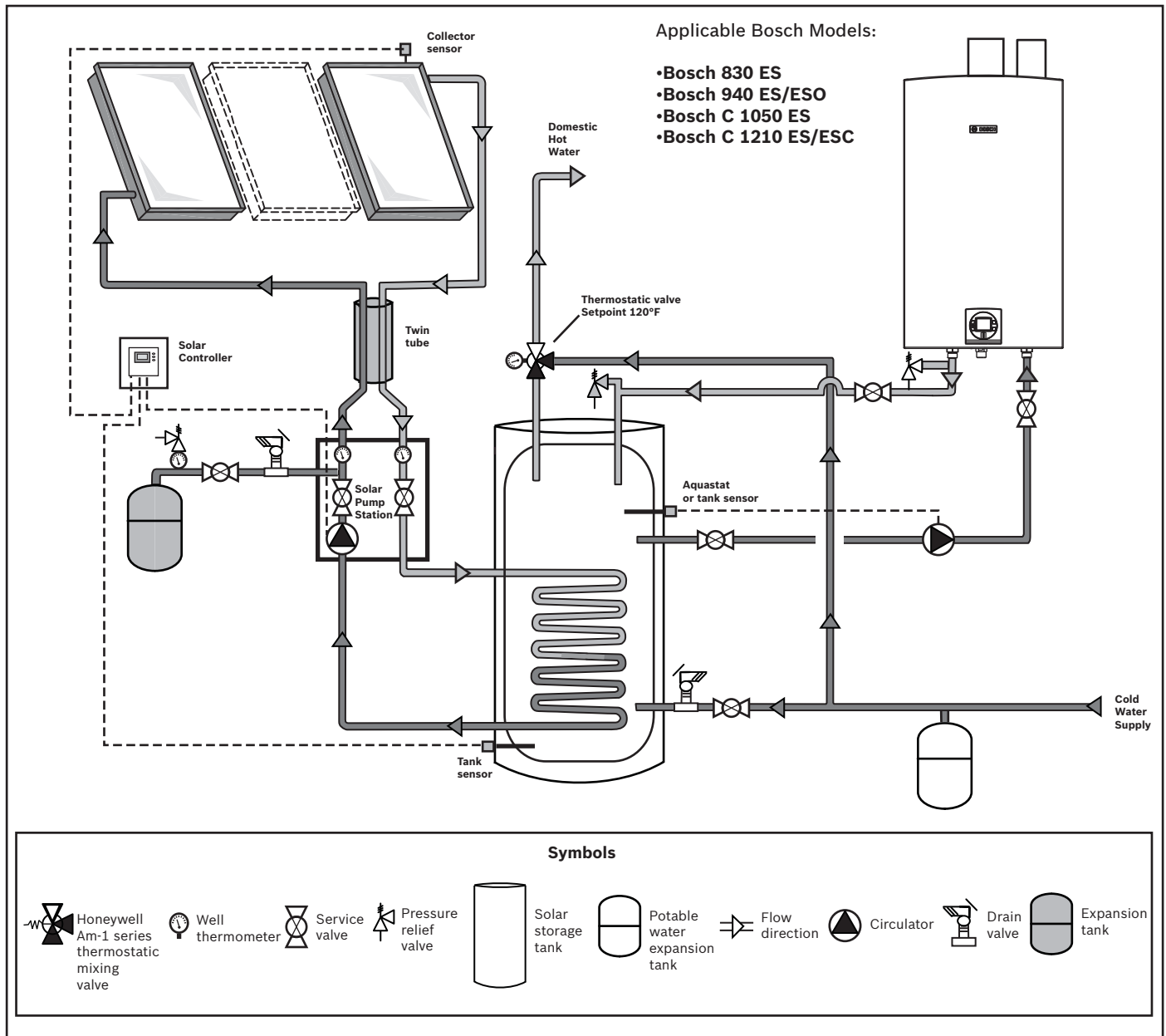

10.2 Booster applications

10.2.1 Solar DHW system with gas tankless water heater booster

The tankless water heater only runs when solar water needs a boost. The Ariston mini tank provides small amounts of DHW instantly and increases comfort by buffering DHW temperature. See applicable models listed in the figure below.

- ▶ Thermostatic valve 1 ensures that warm solar water bypasses the water heater and directs cooler water through the appliance when reheating is needed.
- ▶ Thermostatic valve 2 acts as a tempering valve that brings potentially hot water temperatures down to a level that is safe for the inhabitants.

System parameters:

- ▶ Honeywell AM101 Thermostatic Valves required for proper operation;
- ▶ Remove check valves from Thermostatic Valve 1 as it is used as a diverter valve;
- ▶ Thermostatic Valve 2 is a tempering valve;
- ▶ Recommended setpoint 120°F for both Valves;
- ▶ Set tankless water heater temperature to 140° F
- ▶ Ariston mini tank will provide increased temperature stability and quicker hot water delivery. (recommended but not required)

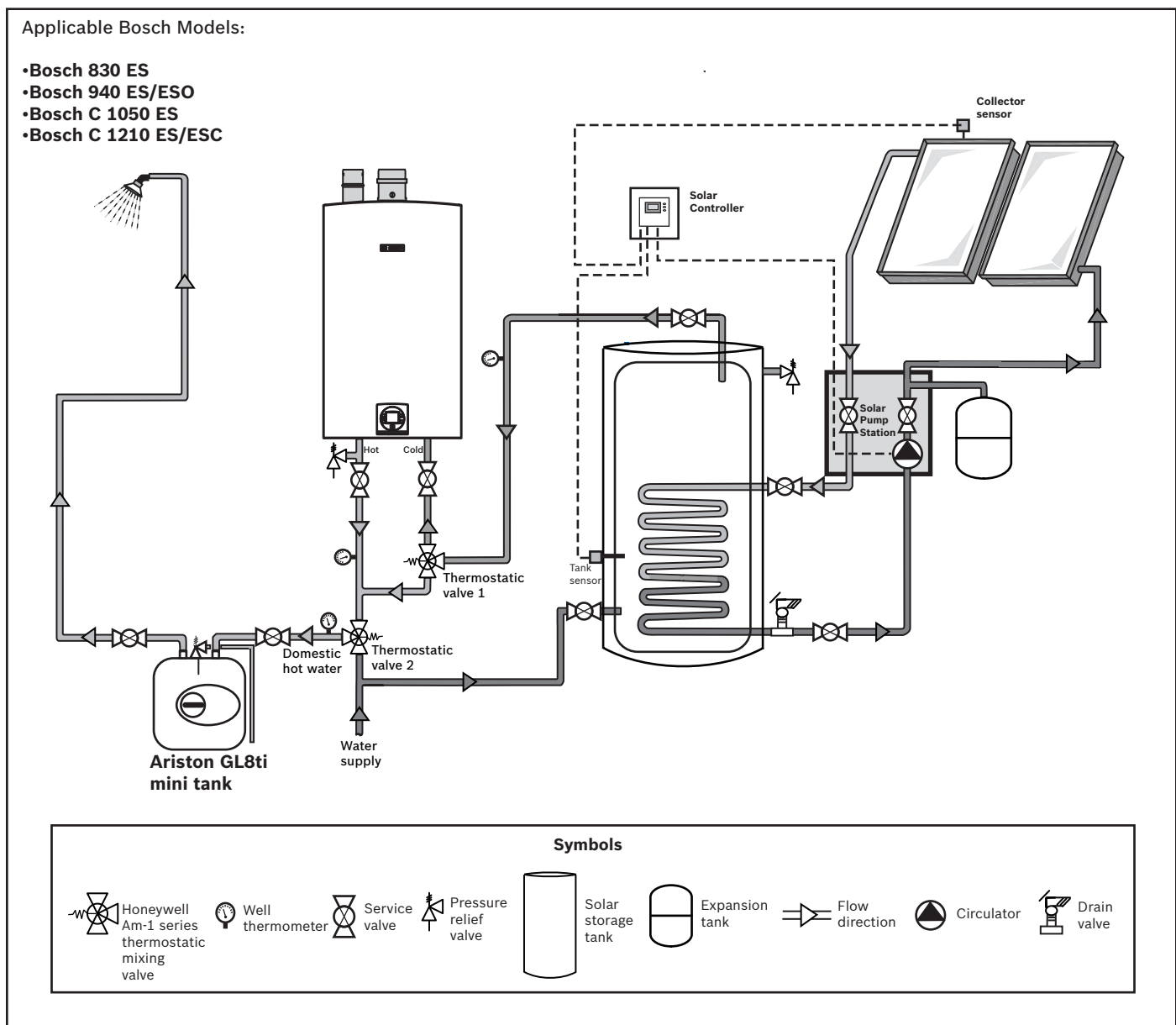

10.2.2 Solar DHW system with gas tankless water heater booster and recirculation loop

Similar to 10.2.1 with domestic hot water recirculation added. The tankless water heater only runs when solar heated water needs a boost. Buffer tank provides small amounts of DHW instantly and increases comfort by smoothing out DHW temperature. See applicable models listed in the figure below.

- ▶ Thermostatic valve 1 ensures that warm solar water bypasses the water heater and directs cooler water through the appliance when reheating is needed.
- ▶ Thermostatic valve 2 acts as a tempering valve that brings potentially hot water temperatures down to a level that is safe for the users.

System parameters:

- ▶ Honeywell AM101 Thermostatic Valves required for proper operation;
- ▶ Remove check valves from Thermostatic Valve 1 as it is used as a diverter valve;
- ▶ Thermostatic Valve 2 is a tempering valve;
- ▶ Recommended setpoint 120°F for both Valves;
- ▶ Set tankless water heater temperature to 140° F
- ▶ Ariston mini tank will provide increased temperature stability and quicker hot water delivery. (recommended but not required)
- ▶ Choose size of the Ariston mini tank to match the volume of the recirculation loop



See Chapter 5 for recirculation pump parameters

Applicable Bosch Models:

- Bosch 830 ES
- Bosch 940 ES/ESO
- Bosch C 1050 ES
- Bosch C 1210 ES/ESC

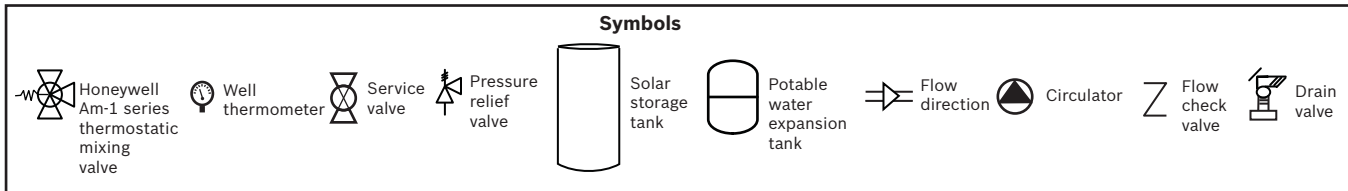
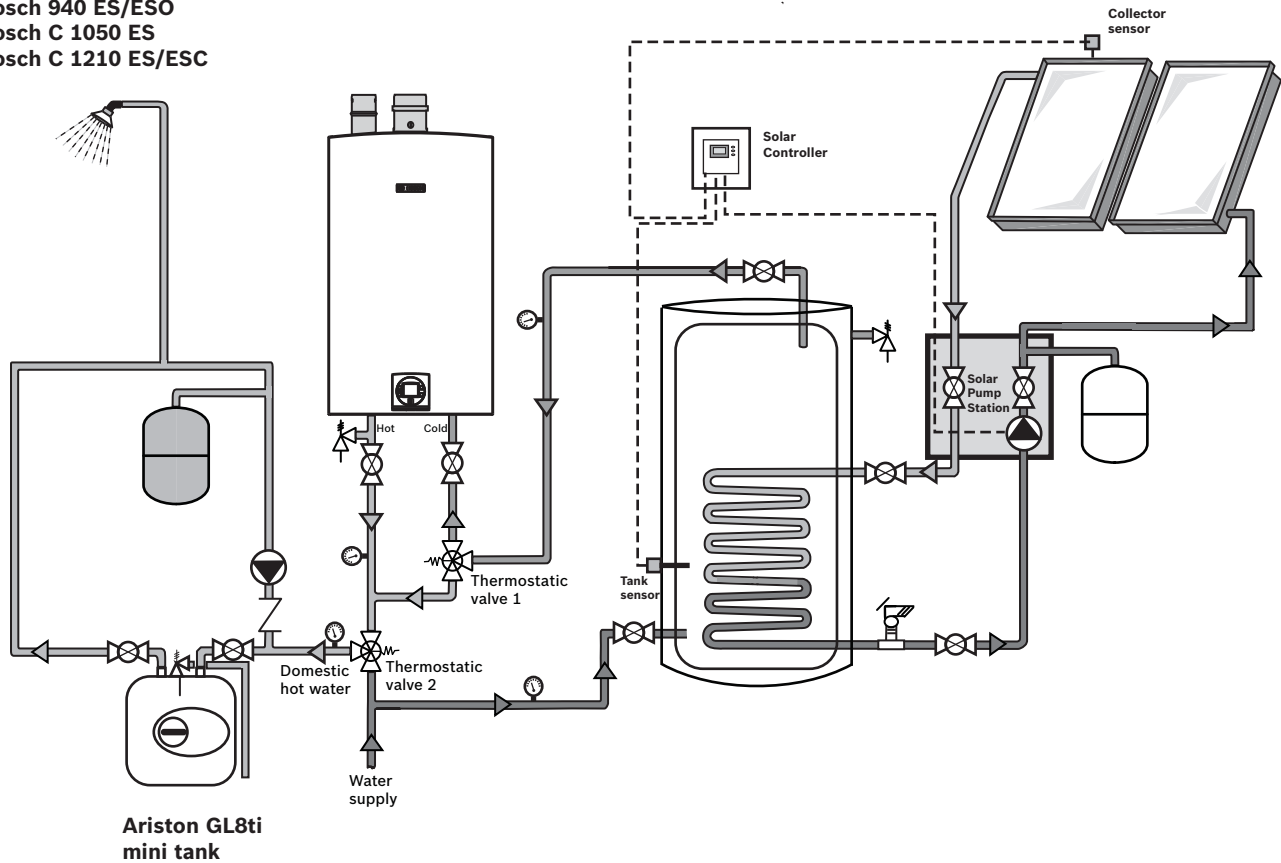

11 Commercial Solar Applications

Introduction

This section provides a general overview for commercial hot water systems in conjunction with solar water heating (e.g. schools, fitness centers). For additional system details, consult the Bosch Solar Technical Guide.

System parameters:

- ▶ Honeywell AM101 Thermostatic Valves required for proper operation.
- ▶ For optimal performance, the flow through the water heater should be between 3.5 -5 gpm



See Chapter 5.1 and 5.2 for recirculation pump parameters

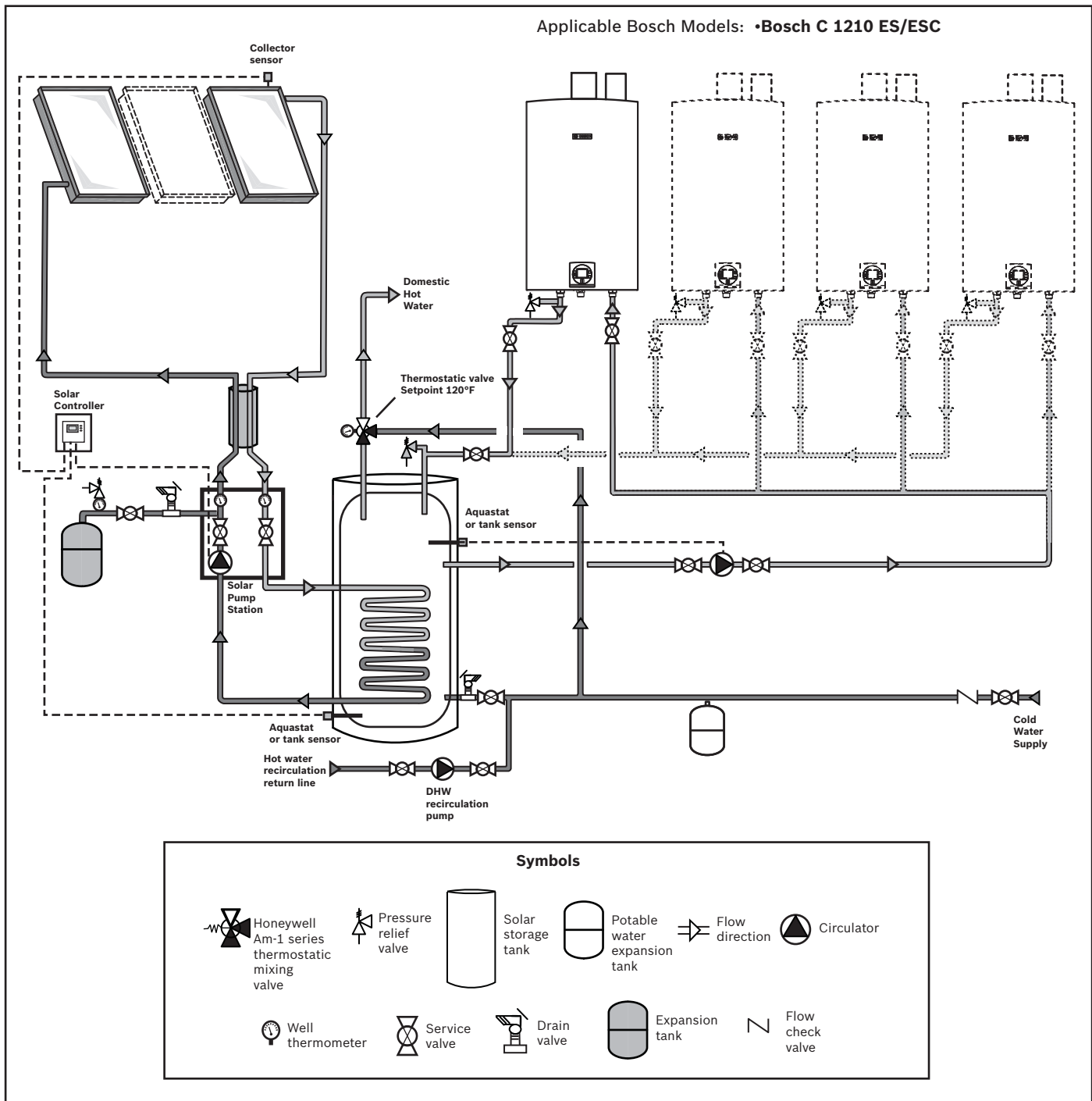

12 Commercial Water Heating Applications

Introduction

This section gives a general overview of high volume, high temperature water heating for commercial applications.

12.1 Commercial Kitchen applications

12.1.1 Commercial kitchen

This design allows for temperature stability with short, repeated hot water demands such as a super sprayer. It also provides high temperature water for a commercial dishwasher.

System parameters:

- ▶ Set Ariston mini-tank to maximum temperature.
- ▶ Set tankless water heater temperature per dishwasher temperature requirements.

i When using the super sprayer, hot water draws must be longer than 15 seconds to avoid temperature fluctuations.

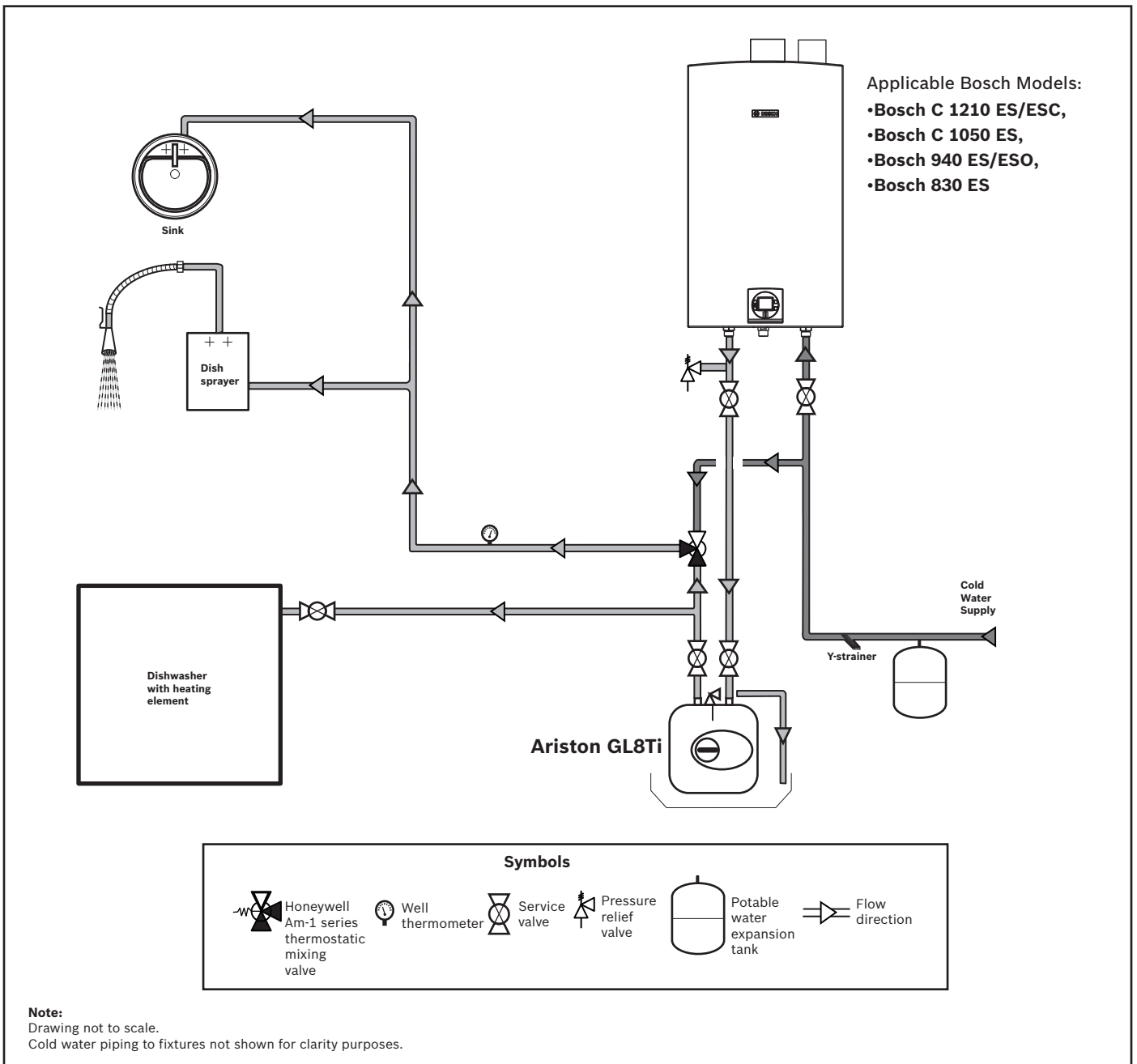

12.1.2 Commercial kitchen with domestic hot water recirculation

System parameters:

- ▶ For optimum performance in applications involving a commercial dishwasher, a hot water circulation loop is recommended.

i See Chapter 5.1 for recirculation pump parameters

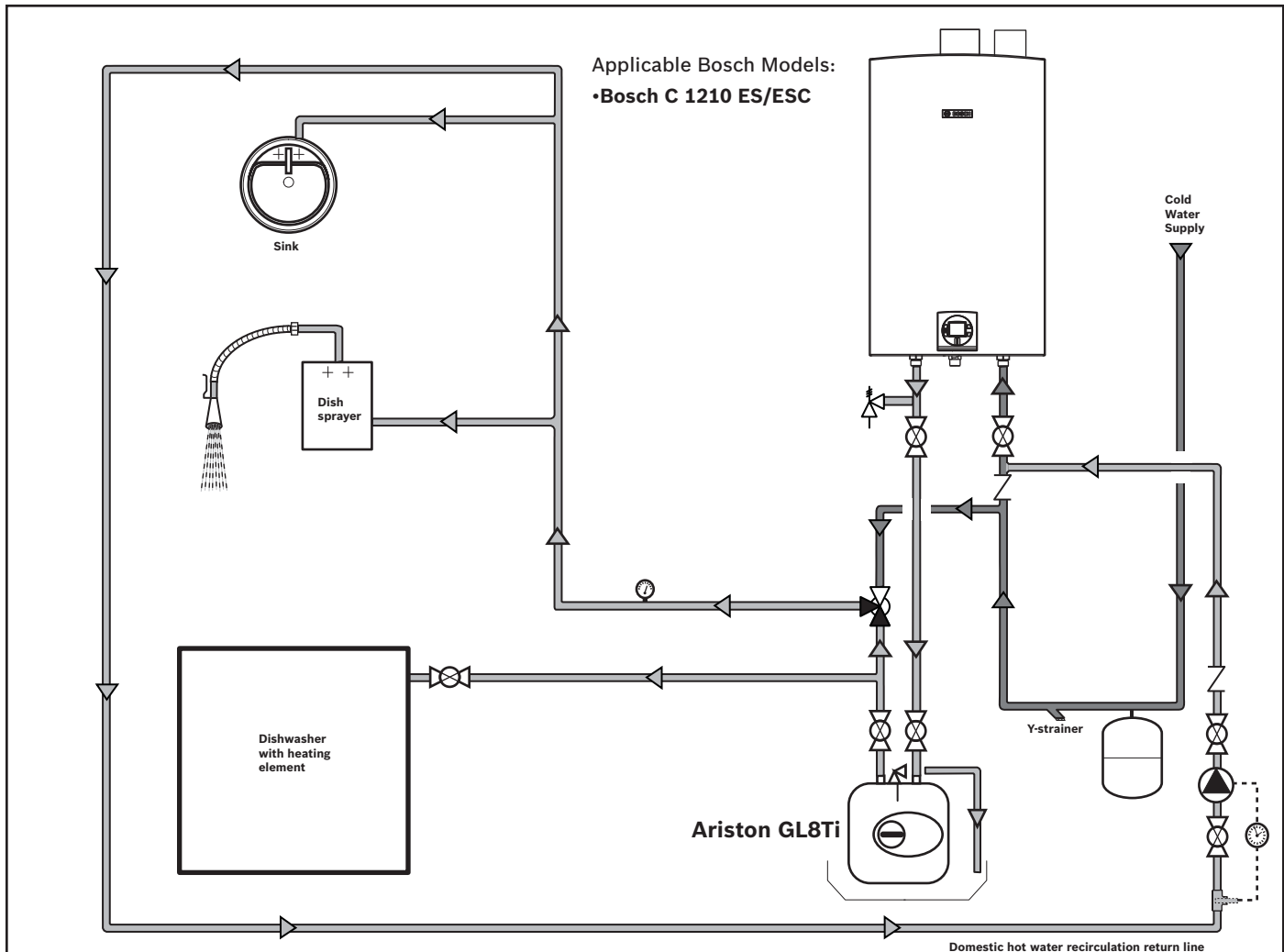

Symbols

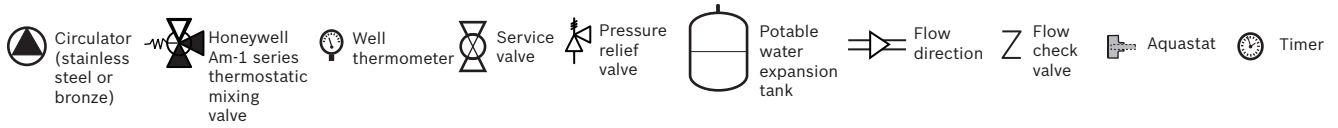

Note:
Drawing not to scale.
Cold water piping to fixtures not shown for clarity purposes.

12.2 Basic tank loading with domestic recirculation

The following application outlines general tank loading with one or more gas tankless water heaters in parallel. Domestic hot water recirculation shown is optional.

System parameters:

- Aquastat/tank sensor Tset 120-140°F, <10°F differential.
- 30-119 gallon storage tank recommended
- DHW return line can tie directly into tank if fittings are available.
- Individual pumps (i.e. UP26-99) can be used on supply to each heater or one pump (as shown) for the entire system



See Chapter 5.1 and 5.2 for pump parameters

Aquastat / Water Heater setpoints		
Model Number	Aquastat setpoint	Water heater setpoint
C 1210 ESC	≤140°F	14°F above Aquastat setpoint
830 ES, 940 ES, C 1050 ES, C 1210 ES	≤126°F*	140°F

* If local codes require higher setpoint or to increase the recovery capacity of the water heater, contact Bosch Thermotechnology.

Applicable Bosch Models:

- Bosch 830 ES
- Bosch C 1050 ES
- Bosch 940 ES
- Bosch C 1210 ES/ESC

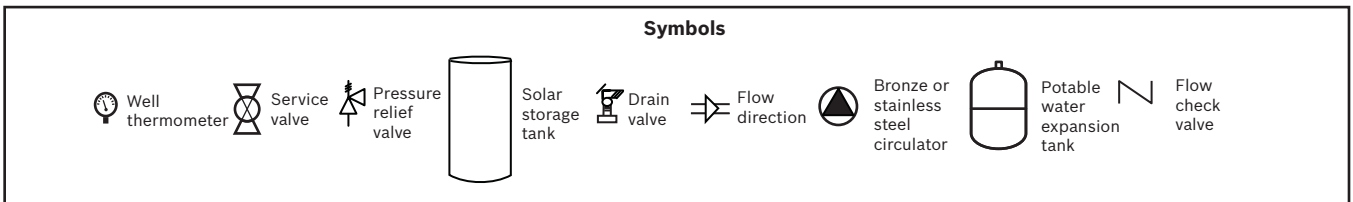
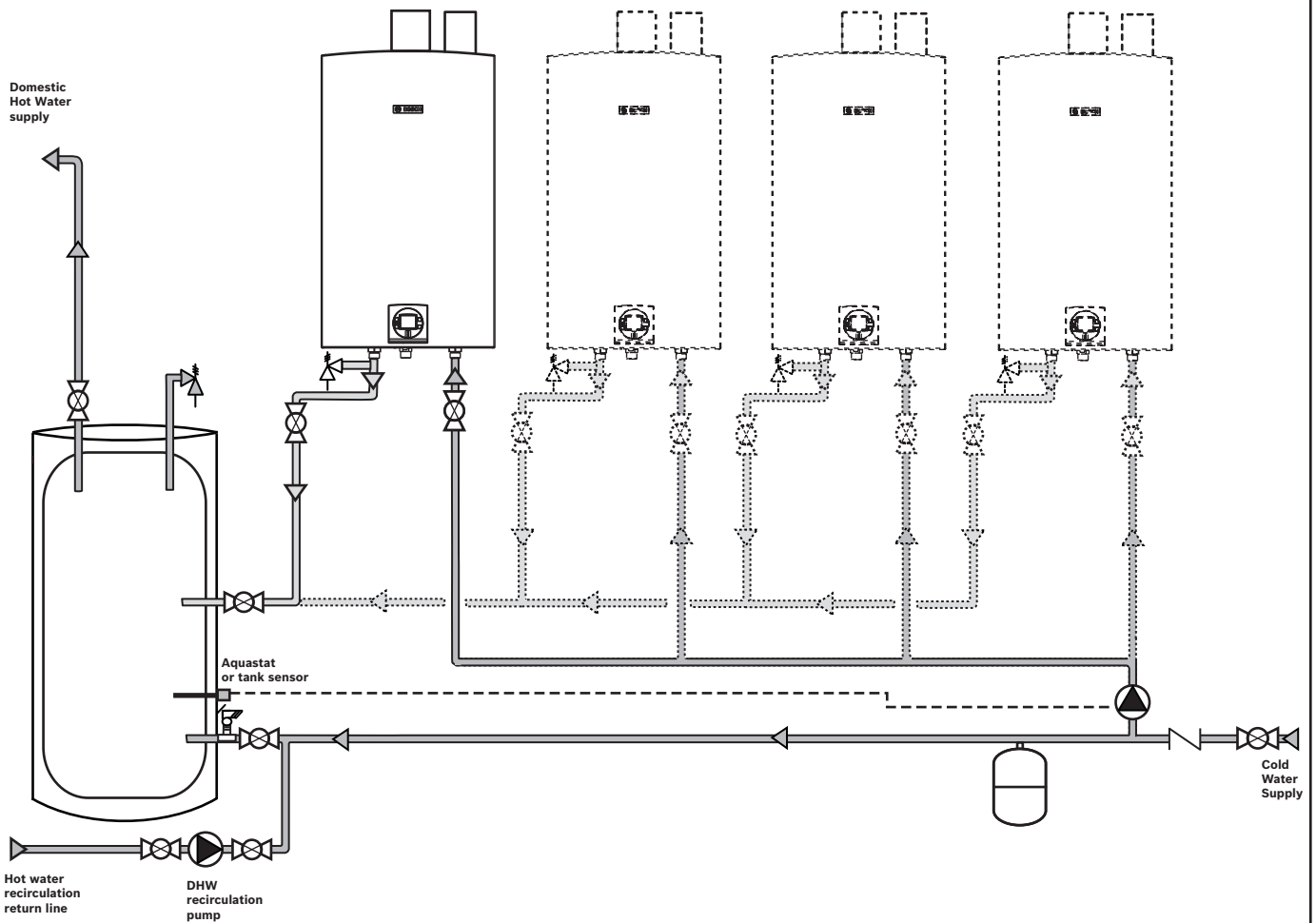

12.3 Advanced tank loading commercial hot water system

The following application outlines an advanced tank loading application for commercial hot water systems (e.g. hotels, fitness centers). This design allows for complete isolation of the system for maintenance reasons and gives the ability to bypass certain system components in case of failure. A second hot water storage tank is shown for additional hot water supply and back up in case of tank failure.

System parameters:

 See Chapter 5.1 and 5.2 for pump parameters

Aquistat / Water Heater setpoints		
Model Number	Aquistat setpoint	Water heater setpoint
C 1210 ESC	≤140°F	14°F above Aquistat setpoint
830 ES 940 ES, C 1050 ES, C 1210 ES	≤126°F*	140°F

* If local codes require higher setpoint or to increase the recovery capacity of the water heater, contact Bosch Thermotechnology.

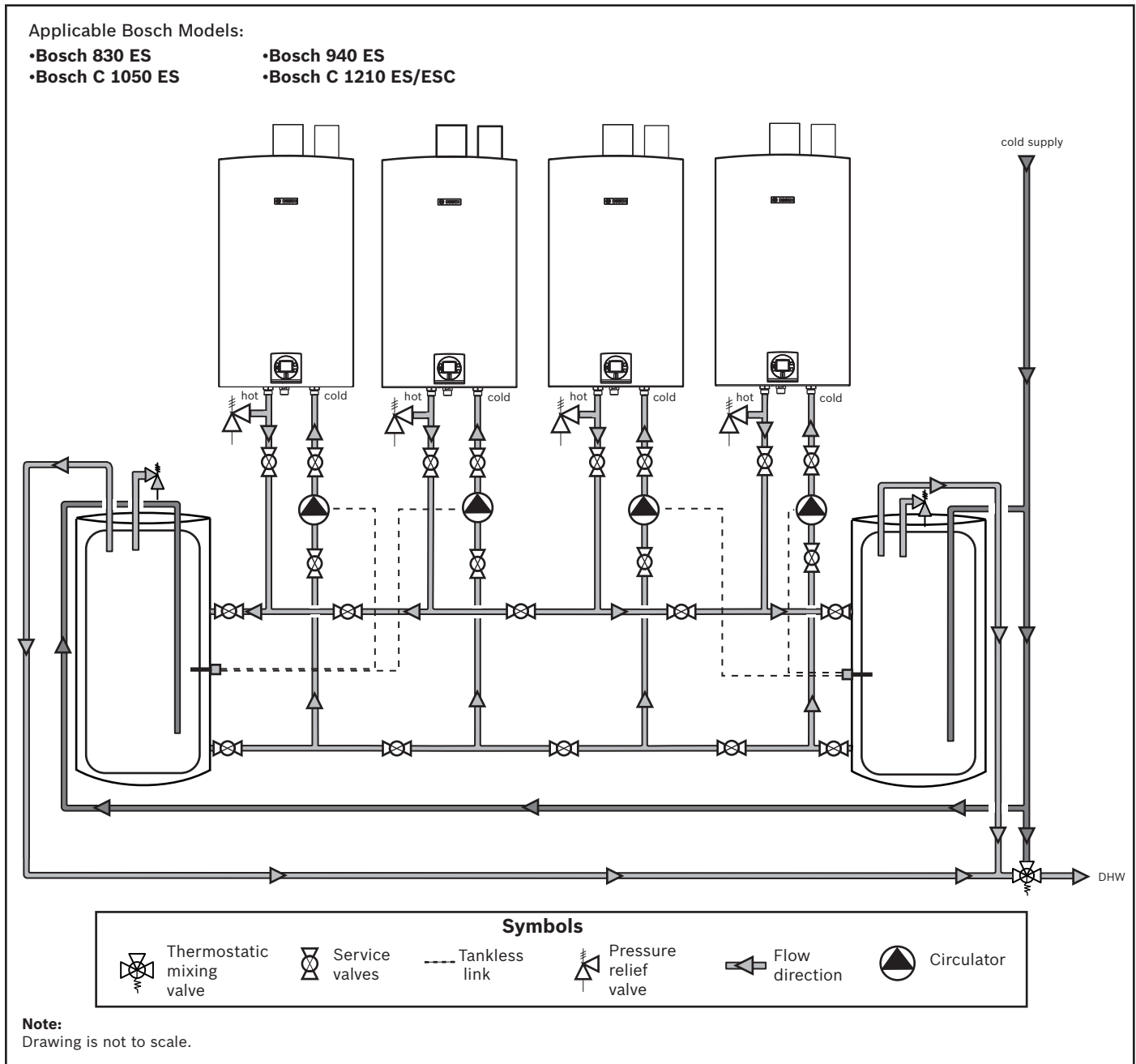



BOSCH

Bosch Thermotechnology Corp.
50 Wentworth Avenue
Londonderry, NH 03053

Tel: 1-866-642-3198
Fax: 1-603-584-1687
www.bosch-climate.us